

## 3-Termal 100mA Positive Voltage Regulator

### DESCRIPTION

The TS78L00 Series of positive voltage Regulators are inexpensive, easy-to-use devices suitable for a multitude of applications that require a regulated supply of up to 100mA. Like their higher power TS7800 and TS78M00 Series cousins, these regulators feature internal current limiting and thermal shutdown making them remarkably rugged. No external components are required with the TS78L00 devices in many applications. These devices offer a substantial performance advantage over the traditional zener diode-resistor combination, as output impedance and quiescent current are substantially reduced.

### FEATURES

- Output Voltage Range 3.3V, 5V, 9V, 12V, 15V, 24V
- Output current up to 100mA
- No external components required
- Internal thermal overload protection
- Internal short-circuit current limiting
- Output transistor safe-area compensation
- Output voltage offered in 4% tolerance
- Compliant to RoHS Directive 2011/65/EU and WEEE 2002/96/EC
- Halogen-free according to IEC 61249-2-21

### APPLICATION

- Switching power supply
- Home appliance



**SOT-89**  
**Pin Definition:**  
1. Output  
2. Ground  
3. Input



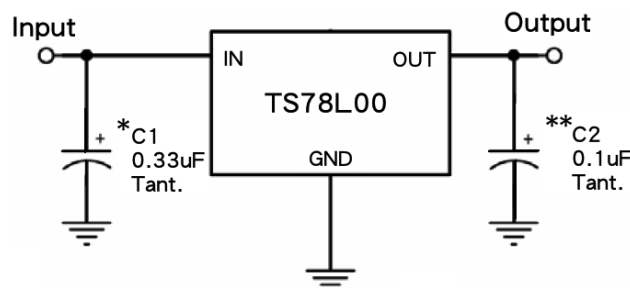
**SOT-23**  
**Pin Definition:**  
1. Output  
2. Input  
3. Ground



**SOP-8**  
**Pin Definition**  
1. Output  
2. Ground  
3. Ground  
4. N/C  
5. N/A  
6. Ground  
7. Ground  
8. Input

**Notes:** MSL 3 (Moisture Sensitivity Level) per J-STD-020

### TYPICAL APPLICATION CIRCUIT



A common ground is required between the input and the output voltages. The input voltage must remain typically 2.0V above the output voltage even during the low point on the Input ripple voltage.

XX = these two digits of the type number indicate voltage.

\* = Cin is required if regulator is located an appreciable distance from power supply filter.

\*\* = Co is not needed for stability; however, it does improve transient response.

<b>ABSOLUTE MAXIMUM RATINGS</b>				
<b>PARAMETER</b>		<b>SYMBOL</b>	<b>LIMIT</b>	<b>UNIT</b>
DC Input Voltage	TS78L03	$V_{IN}$	30	V
	TS78L05		35	
	TS78L09		35	
	TS78L12		35	
	TS78L15		35	
	TS78L24		40	
Power Dissipation		$P_D$	Internally Limited	W
Operating Junction Temperature Range		$T_J$	0 ~ +150	°C
Storage Temperature Range		$T_{STG}$	-65~+150	°C

<b>THERMAL PERFORMANCE</b>					
<b>PARAMETER</b>	<b>SYMBOL</b>	<b>LIMIT</b>			<b>UNIT</b>
		<b>SOT-23</b>	<b>SOT-89</b>	<b>SOP-8</b>	
Junction to Case Thermal Resistance	$R_{\theta JC}$	120	15	20	°C/W
Junction to Ambient Thermal Resistance	$R_{\theta JA}$	330	55	55	°C/W

**Notes:**  $R_{\theta JA}$  is the sum of the junction-to-case and case-to-ambient thermal resistances. The case thermal reference is defined at the solder mounting surface of the drain pins.  $R_{\theta JA}$  is guaranteed by design while  $R_{\theta CA}$  is determined by the user's board design.  $R_{\theta JA}$  shown below for single device operation on FR-4 PCB in still air.

**ELECTRICAL SPECIFICATIONS TS78L03**

 ( $V_{IN}=8.3V$ ,  $I_{OUT}=40mA$ ,  $0^{\circ}C \leq T_J \leq 125^{\circ}C$ ,  $C_{IN}=0.33\mu F$ ,  $C_{OUT}=0.1\mu F$ , unless otherwise noted)

PARAMETER	CONDITIONS		SYMBOL	MIN	TYP	MAX	UNIT
Output voltage	$T_J=25^{\circ}C$		$V_{OUT}$	3.173	3.3	3.432	V
	$5.8V \leq V_{IN} \leq 20V$ , $5mA \leq I_{OUT} \leq 100mA$			3.142	3.3	3.465	V
Line Regulation	$T_J=25^{\circ}C$	$5.8V \leq V_{IN} \leq 20V$ $I_{OUT}=40mA$	$REG_{LINE}$	--	50	150	mV
Load Regulation	$T_J=25^{\circ}C$	$5mA \leq I_{OUT} \leq 100mA$	$REG_{LOAD}$	--	15	60	mV
		$5mA \leq I_{OUT} \leq 40mA$		--	5	30	
Quiescent Current	$I_{OUT}=0$ , $T_J=25^{\circ}C$		$I_Q$	--	3	6	mA
Quiescent Current Change	$5.8V \leq V_{IN} \leq 20V$		$\Delta I_Q$	--	--	1.5	mA
	$5mA \leq I_{OUT} \leq 40mA$			--	--	0.1	
Output Noise Voltage	$10Hz \leq f \leq 100KHz$ , $T_J=25^{\circ}C$		$V_N$	--	40	--	$\mu V$
Ripple Rejection Ratio	$F=120Hz$ , $5.8V \leq V_{IN} \leq 20V$		RR	41	49	--	dB
Voltage Drop	$I_{OUT}=100mA$ , $T_J=25^{\circ}C$		$V_{DROP}$	--	2	--	V
Peak Output Current	$T_J=25^{\circ}C$		$I_{o\ peak}$	--	0.15	--	A
Temperature Coefficient of Output Voltage	$I_{OUT}=5mA$ , $0^{\circ}C \leq T_J \leq 150^{\circ}C$		$\Delta V_{OUT} / \Delta T_J$	--	-0.2	--	mV/°C

**ELECTRICAL SPECIFICATIONS TS78L05**

 ( $V_{IN}=10V$ ,  $I_{OUT}=40mA$ ,  $0^{\circ}C \leq T_J \leq 125^{\circ}C$ ,  $C_{IN}=0.33\mu F$ ,  $C_{OUT}=0.1\mu F$ , unless otherwise noted)

PARAMETER	CONDITIONS		SYMBOL	MIN	TYP	MAX	UNIT
Output voltage	$T_J=25^{\circ}C$		$V_{OUT}$	4.80	5	5.20	V
	$7.5V \leq V_{IN} \leq 20V$ , $5mA \leq I_{OUT} \leq 100mA$			4.75	5	5.25	V
Line Regulation	$T_J=25^{\circ}C$	$7.5V \leq V_{IN} \leq 20V$ $I_{OUT}=100mA$	$REG_{LINE}$	50	150	150	mV
Load Regulation	$T_J=25^{\circ}C$	$5mA \leq I_{OUT} \leq 100mA$	$REG_{LOAD}$	20	60	60	mV
		$5mA \leq I_{OUT} \leq 40mA$		10	30	30	
Quiescent Current	$I_{OUT}=0$ , $T_J=25^{\circ}C$		$I_Q$	--	3	6	mA
Quiescent Current Change	$7.5V \leq V_{IN} \leq 20V$		$\Delta I_Q$	--	--	1.5	mA
	$5mA \leq I_{OUT} \leq 40mA$			--	--	0.1	
Output Noise Voltage	$10Hz \leq f \leq 100KHz$ , $T_J=25^{\circ}C$		$V_N$	--	40	--	$\mu V$
Ripple Rejection Ratio	$F=120Hz$ , $7.5V \leq V_{IN} \leq 20V$		RR	41	49	--	dB
Voltage Drop	$I_{OUT}=100mA$ , $T_J=25^{\circ}C$		$V_{DROP}$	--	1.7	--	V
Peak Output Current	$T_J=25^{\circ}C$		$I_{o\ peak}$	--	0.15	--	A
Temperature Coefficient of Output Voltage	$I_{OUT}=5mA$ , $0^{\circ}C \leq T_J \leq 150^{\circ}C$		$\Delta V_{OUT} / \Delta T_J$	--	-0.65	--	mV/°C

**Note:**

- Pulse testing techniques are used to maintain the junction temperature as close to the ambient temperature as possible, and thermal effects must be taken into account separately
- This specification applies only for DC power dissipation permitted by absolute maximum ratings.

**ELECTRICAL SPECIFICATIONS TS78L09**

 ( $V_{IN}=15V$ ,  $I_{OUT}=40mA$ ,  $0^{\circ}C \leq T_J \leq 125^{\circ}C$ ,  $C_{IN}=0.33\mu F$ ,  $C_{OUT}=0.1\mu F$ , unless otherwise noted)

PARAMETER	CONDITIONS	SYMBOL	MIN	TYP	MAX	UNIT	
Output voltage	$T_J=25^{\circ}C$	$V_{OUT}$	8.65	9	9.36	V	
	$11.5V \leq V_{IN} \leq 23V$ , $5mA \leq I_{OUT} \leq 100mA$		8.57	9	9.45	V	
Line Regulation	$T_J=25^{\circ}C$ $11.5V \leq V_{IN} \leq 23V$ $I_{OUT}=40mA$	$REG_{LINE}$	--	90	180	mV	
Load Regulation	$T_J=25^{\circ}C$	$REG_{LOAD}$	$5mA \leq I_{OUT} \leq 100mA$	--	30	90	mV
			$5mA \leq I_{OUT} \leq 40mA$	--	15	45	
Quiescent Current	$I_{OUT}=0$ , $T_J=25^{\circ}C$	$I_Q$	--	3	6	mA	
Quiescent Current Change	$11.5V \leq V_{IN} \leq 23V$	$\Delta I_Q$	--	--	1.5	mA	
	$5mA \leq I_{OUT} \leq 40mA$		--	--	0.1		
Output Noise Voltage	$10Hz \leq f \leq 100KHz$ , $T_J=25^{\circ}C$	$V_N$	--	60	--	$\mu V$	
Ripple Rejection Ratio	$F=120Hz$ , $11.5V \leq V_{IN} \leq 23V$	RR	37	57	--	dB	
Voltage Drop	$I_{OUT}=100mA$ , $T_J=25^{\circ}C$	$V_{DROP}$	--	1.7	--	V	
Peak Output Current	$T_J=25^{\circ}C$	$I_{o\ peak}$	--	0.15	--	A	
Temperature Coefficient of Output Voltage	$I_{OUT}=5mA$ , $0^{\circ}C \leq T_J \leq 150^{\circ}C$	$\Delta V_{OUT} / \Delta T_J$	--	-0.9	--	mV/ $^{\circ}C$	

**ELECTRICAL SPECIFICATIONS TS78L12**

 ( $V_{IN}=19V$ ,  $I_{OUT}=40mA$ ,  $0^{\circ}C \leq T_J \leq 125^{\circ}C$ ,  $C_{IN}=0.33\mu F$ ,  $C_{OUT}=0.1\mu F$ , unless otherwise noted)

PARAMETER	CONDITIONS	SYMBOL	MIN	TYP	MAX	UNIT	
Output voltage	$T_J=25^{\circ}C$	$V_{OUT}$	11.53	12	12.48	V	
	$14.5V \leq V_{IN} \leq 27V$ , $5mA \leq I_{OUT} \leq 100mA$		11.42	12	12.60	V	
Line Regulation	$T_J=25^{\circ}C$ $14.5V \leq V_{IN} \leq 27V$ $I_{OUT}=40mA$	$REG_{LINE}$	--	120	240	mV	
Load Regulation	$T_J=25^{\circ}C$	$REG_{LOAD}$	$5mA \leq I_{OUT} \leq 100mA$	--	40	120	mV
			$5mA \leq I_{OUT} \leq 40mA$	--	20	60	
Quiescent Current	$I_{OUT}=0$ , $T_J=25^{\circ}C$	$I_Q$	--	3	6.5	mA	
Quiescent Current Change	$14.5V \leq V_{IN} \leq 27V$	$\Delta I_Q$	--	--	1.5	mA	
	$5mA \leq I_{OUT} \leq 40mA$		--	--	0.1		
Output Noise Voltage	$10Hz \leq f \leq 100KHz$ , $T_J=25^{\circ}C$	$V_N$	--	80	--	$\mu V$	
Ripple Rejection Ratio	$F=120Hz$ , $14.5V \leq V_{IN} \leq 27V$	RR	37	42	--	dB	
Voltage Drop	$I_{OUT}=100mA$ , $T_J=25^{\circ}C$	$V_{DROP}$	--	1.7	--	V	
Peak Output Current	$T_J=25^{\circ}C$	$I_{o\ peak}$	--	0.15	--	A	
Temperature Coefficient of Output Voltage	$I_{OUT}=5mA$ , $0^{\circ}C \leq T_J \leq 150^{\circ}C$	$\Delta V_{OUT} / \Delta T_J$	--	-1.0	--	mV/ $^{\circ}C$	

**Note:**

- Pulse testing techniques are used to maintain the junction temperature as close to the ambient temperature as possible, and thermal effects must be taken into account separately
- This specification applies only for DC power dissipation permitted by absolute maximum ratings.

**ELECTRICAL SPECIFICATIONS TS78L15**

 ( $V_{IN}=23V$ ,  $I_{OUT}=40mA$ ,  $0^{\circ}C \leq T_J \leq 125^{\circ}C$ ,  $C_{IN}=0.33\mu F$ ,  $C_{OUT}=0.1\mu F$ , unless otherwise noted)

PARAMETER	CONDITIONS		SYMBOL	MIN	TYP	MAX	UNIT
Output voltage	$T_J=25^{\circ}C$		$V_{OUT}$	14.42	15	15.60	V
	$17.5V \leq V_{IN} \leq 30V$ , $5mA \leq I_{OUT} \leq 100mA$			14.28	15	15.75	V
Line Regulation	$T_J=25^{\circ}C$	$17.5V \leq V_{IN} \leq 30V$ $I_{OUT}=40mA$	$REG_{LINE}$	--	150	300	mV
Load Regulation	$T_J=25^{\circ}C$	$5mA \leq I_{OUT} \leq 100mA$	$REG_{LOAD}$	--	50	150	mV
		$5mA \leq I_{OUT} \leq 40mA$		--	25	75	
Quiescent Current	$I_{OUT}=0$ , $T_J=25^{\circ}C$		$I_Q$	--	3	6.6	mA
Quiescent Current Change	$17.5V \leq V_{IN} \leq 30V$		$\Delta I_Q$	--	--	1.5	mA
	$5mA \leq I_{OUT} \leq 40mA$			--	--	0.1	
Output Noise Voltage	$10Hz \leq f \leq 100KHz$ , $T_J=25^{\circ}C$		$V_N$	--	90	--	$\mu V$
Ripple Rejection Ratio	$F=120Hz$ , $17.5V \leq V_{IN} \leq 30V$		RR	34	39	--	dB
Voltage Drop	$I_{OUT}=100mA$ , $T_J=25^{\circ}C$		$V_{DROP}$	--	1.7	--	V
Peak Output Current	$T_J=25^{\circ}C$		$I_{o\ peak}$	--	0.15	--	A
Temperature Coefficient of Output Voltage	$I_{OUT}=5mA$ , $0^{\circ}C \leq T_J \leq 150^{\circ}C$		$\Delta V_{OUT} / \Delta T_J$	--	-1.3	--	mV/ $^{\circ}C$

**ELECTRICAL SPECIFICATIONS TS78L24**

 ( $V_{IN}=33V$ ,  $I_{OUT}=40mA$ ,  $0^{\circ}C \leq T_J \leq 125^{\circ}C$ ,  $C_{IN}=0.33\mu F$ ,  $C_{OUT}=0.1\mu F$ , unless otherwise noted)

PARAMETER	CONDITIONS		SYMBOL	MIN	TYP	MAX	UNIT
Output voltage	$T_J=25^{\circ}C$		$V_{OUT}$	23.07	24	24.96	V
	$27V \leq V_{IN} \leq 38V$ , $5mA \leq I_{OUT} \leq 100mA$			22.85	24	25.20	V
Line Regulation	$T_J=25^{\circ}C$	$27V \leq V_{IN} \leq 38V$ $I_{OUT}=40mA$	$REG_{LINE}$	--	200	400	mV
Load Regulation	$T_J=25^{\circ}C$	$5mA \leq I_{OUT} \leq 100mA$	$REG_{LOAD}$	--	80	240	mV
		$5mA \leq I_{OUT} \leq 40mA$		--	40	120	
Quiescent Current	$I_{OUT}=0$ , $T_J=25^{\circ}C$		$I_Q$	--	4	7	mA
Quiescent Current Change	$27V \leq V_{IN} \leq 38V$		$\Delta I_Q$	--	--	1.5	mA
	$5mA \leq I_{OUT} \leq 40mA$			--	--	0.1	
Output Noise Voltage	$10Hz \leq f \leq 100KHz$ , $T_J=25^{\circ}C$		$V_N$	--	200	--	$\mu V$
Ripple Rejection Ratio	$F=120Hz$ , $27V \leq V_{IN} \leq 38V$		RR	31	45	--	dB
Voltage Drop	$I_{OUT}=100mA$ , $T_J=25^{\circ}C$		$V_{DROP}$	--	1.7	--	V
Peak Output Current	$T_J=25^{\circ}C$		$I_{o\ peak}$	--	0.15	--	A
Temperature Coefficient of Output Voltage	$I_{OUT}=5mA$ , $0^{\circ}C \leq T_J \leq 150^{\circ}C$		$\Delta V_{OUT} / \Delta T_J$	--	-2.0	--	mV/ $^{\circ}C$

**Note:**

- Pulse testing techniques are used to maintain the junction temperature as close to the ambient temperature as possible, and thermal effects must be taken into account separately
- This specification applies only for DC power dissipation permitted by absolute maximum ratings.

**ORDERING INFORMATION**

OUTPUT VOLTAGE	PART NO.	PACKAGE	PACKING
3.3V	TS78L03ACY RMG	SOT-89	1,000pcs / 7" Reel
	TS78L03CX RFG	SOT-23	3,000pcs / 7" Reel
	TS78L03CS RLG	SOP-8	2,500pcs / 13" Reel
5V	TS78L05ACY RMG	SOT-89	1,000pcs / 7" Reel
	TS78L05CX RFG	SOT-23	3,000pcs / 7" Reel
	TS78L05CS RLG	SOP-8	2,500pcs / 13" Reel
9V	TS78L09ACY RMG	SOT-89	1,000pcs / 7" Reel
	TS78L09CX RFG	SOT-23	3,000pcs / 7" Reel
	TS78L09CS RLG	SOP-8	2,500pcs / 13" Reel
12V	TS78L12ACY RMG	SOT-89	1,000pcs / 7" Reel
	TS78L12CS RLG	SOP-8	2,500pcs / 13" Reel
15V	TS78L15ACY RMG	SOT-89	1,000pcs / 7" Reel
	TS78L15CS RLG	SOP-8	2,500pcs / 13" Reel
24V	TS78L24CS RLG	SOP-8	2,500pcs / 13" Reel

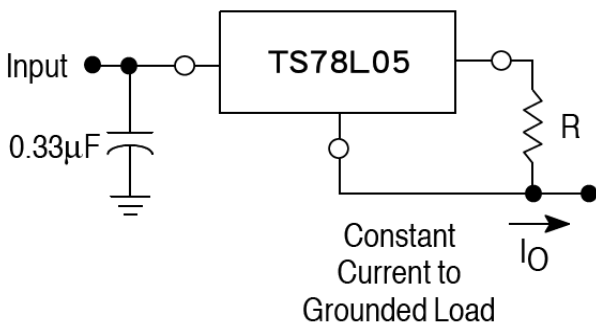
**APPLICATION INFORMATION**

**Design Considerations**

The TS78L00 Series of fixed voltage regulators are designed with Thermal Overload Protection that shuts down the circuit when subjected to an excessive power overload condition. Internal Short Circuit protection limits the maximum current the circuit will pass.

In many low current applications, compensation capacitors are not required. However, it is recommended that the regulator input be bypassed with a capacitor if the regulator is connected to the power supply filter with long wire lengths, or if the output load capacitance is large. The input bypass capacitor should be selected to provide good high-frequency characteristics to insure stable operation under all load conditions. A 0.33µF or larger tantalum, mylar, or other capacitor having low internal impedance at high frequencies should be chosen. The bypass capacitor should be mounted with the shortest possible leads directly across the regulators input terminals. Good construction techniques should be used to minimize ground loops and lead resistance drops since the regulator has no external sense lead. Bypassing the output is also recommended.

**FIGURE 1 – Current Regulator**



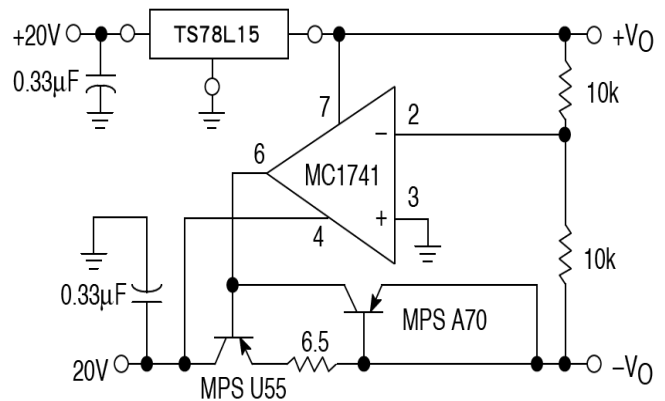
The TS78L00 regulators can also be used as a current source when connected as above. In order to minimize dissipation the TS78L05 is chosen in this application. Resistor R determines the current as follows:

$$I_O = \frac{5.0V}{R} + I_B$$

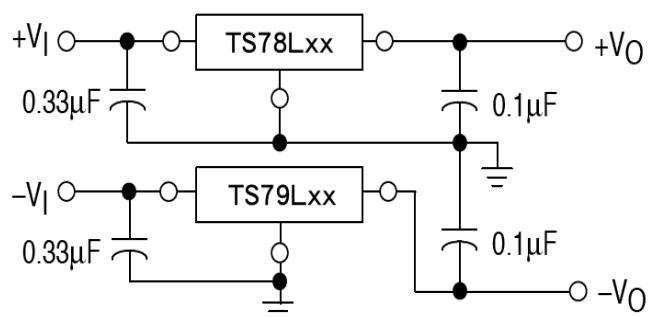
$I_B = 3.8mA$  over lined and load changes

For example, a 100mA current source would require R to be a 50Ω, 1/2W resistor and the output voltage compliance would be the input voltage less 7V.

**FIGURE 2 – ±15V Tracking Voltage Regulator**

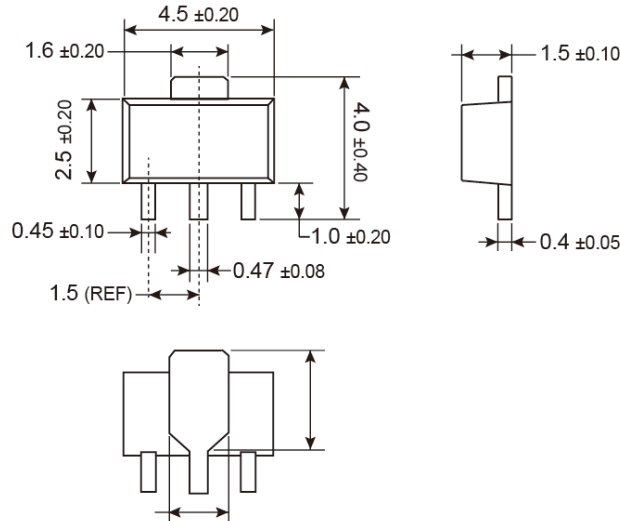


**FIGURE 3 – ±15V Tracking Voltage Regulator**

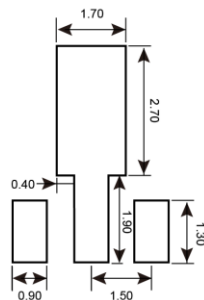


**PACKAGE OUTLINE DIMENSIONS** (Unit: Millimeters)

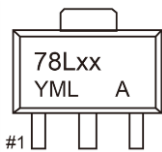
**SOT-89**



**SUGGESTED PAD LAYOUT** (Unit: Millimeters)



**MARKING DIAGRAM**

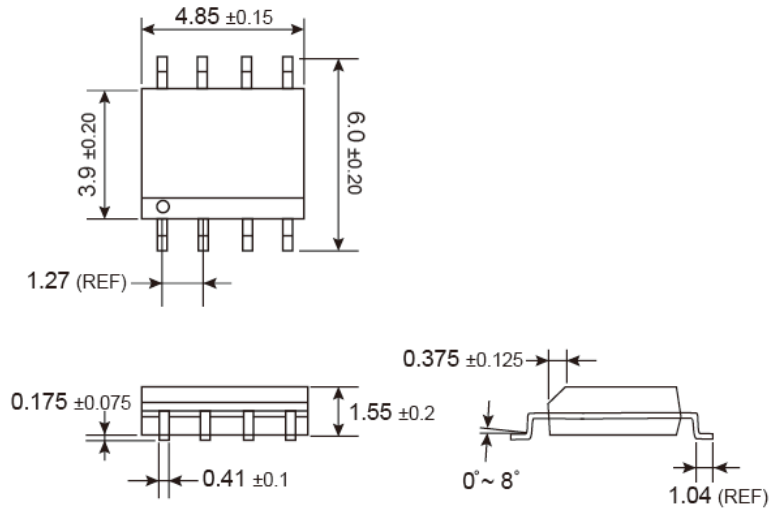


- XX** = Output Voltage  
**03** =3.3V **05** =5.0V **09** =9V **12** =12V **15** =15V
- Y** = Year Code
- M** = Month Code for Halogen Free Product  
**O** =Jan **P** =Feb **Q** =Mar **R** =Apr  
**S** =May **T** =Jun **U** =Jul **V** =Aug  
**W** =Sep **X** =Oct **Y** =Nov **Z** =Dec
- L** = Lot Code

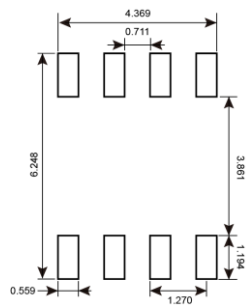


**PACKAGE OUTLINE DIMENSIONS** (Unit: Millimeters)

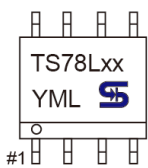
**SOP-08**



**SUGGESTED PAD LAYOUT** (Unit: Millimeters)



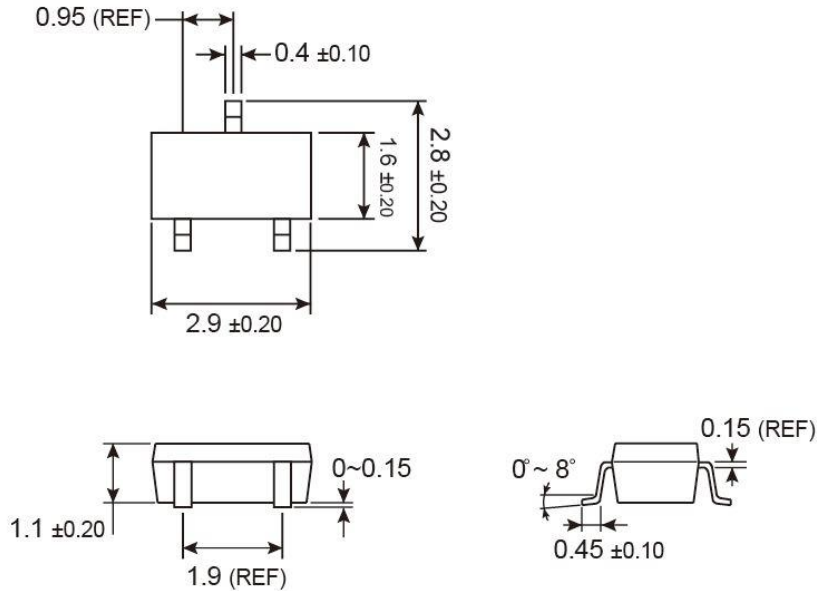
**MARKING DIAGRAM**



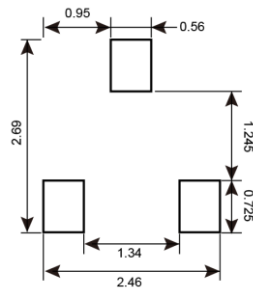
- XX** = Output Voltage
  - 03** =3.3V   **05** =5.0V   **09** =9V   **12** =12V   **15** =15V
  - 24** =24V
- Y** = Year Code
- M** = Month Code for Halogen Free Product
  - O** =Jan   **P** =Feb   **Q** =Mar   **R** =Apr
  - S** =May   **T** =Jun   **U** =Jul   **V** =Aug
  - W** =Sep   **X** =Oct   **Y** =Nov   **Z** =Dec
- L** = Lot Code

**PACKAGE OUTLINE DIMENSIONS** (Unit: Millimeters)

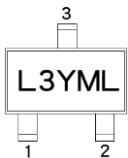
**SOT-23**



**SUGGESTED PAD LAYOUT** (Unit: Millimeters)



**MARKING DIAGRAM**



- XX** = Output Voltage  
**L3** =3.3V **L5** =5.0V **L9** =9V
- Y** = Year Code
- M** = Month Code for Halogen Free Product  
**O** =Jan **P** =Feb **Q** =Mar **R** =Apr  
**S** =May **T** =Jun **U** =Jul **V** =Aug  
**W** =Sep **X** =Oct **Y** =Nov **Z** =Dec
- L** = Lot Code

## Notice

Specifications of the products displayed herein are subject to change without notice. TSC or anyone on its behalf, assumes no responsibility or liability for any errors or inaccuracies.

Information contained herein is intended to provide a product description only. No license, express or implied, to any intellectual property rights is granted by this document. Except as provided in TSC's terms and conditions of sale for such products, TSC assumes no liability whatsoever, and disclaims any express or implied warranty, relating to sale and/or use of TSC products including liability or warranties relating to fitness for a particular purpose, merchantability, or infringement of any patent, copyright, or other intellectual property right.

The products shown herein are not designed for use in medical, life-saving, or life-sustaining applications. Customers using or selling these products for use in such applications do so at their own risk and agree to fully indemnify TSC for any damages resulting from such improper use or sale.