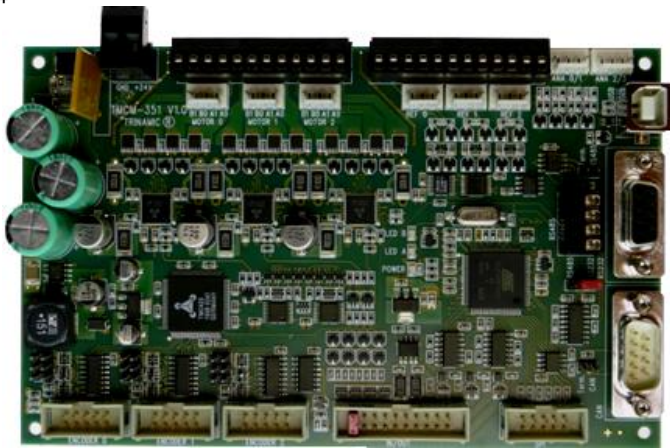


V 1.06

HARDWARE MANUAL



TMCM-351

3-axis stepper motor
controller and driver board
2.8A RMS

7... 28.5V DC

SPI, RS232, RS485, CAN, and USB

Encoder interface

TRINAMIC Motion Control GmbH & Co. KG
Hamburg, Germany

www.trinamic.com



TRINAMIC
MOTION CONTROL

Table of Contents

1	Life support policy	3
2	Features	4
3	Order codes	5
4	Mechanical and electrical interfacing	6
4.1	Dimensions	6
4.2	Connectors	7
4.2.1	Power connector	9
4.2.2	Motor connector	9
4.2.3	Reference connector	10
4.2.4	Analog input connector	12
4.2.5	USB connector	12
4.2.6	RS232 connector	12
4.2.7	CAN connector	13
4.2.8	RS485 connector	13
4.2.9	SPI connector	13
4.2.10	I/O connector	14
4.2.11	Encoder_0/1/2 connector	16
4.3	Jumpers	17
4.3.1	J1: RS485 bus termination	17
4.3.2	J2: RS232 / RS485 interface selection	17
4.3.3	J3: CAN bus termination	18
4.3.4	J4 – J12: Encoder input termination	18
4.3.5	Enable all driver stages permanently	18
5	Operational Ratings	19
6	Functional description	21
6.1	System architecture	21
6.1.1	Microcontroller	21
6.1.2	EEPROM	22
6.1.3	TMC428 motion controller	22
6.1.4	Stepper motor drivers	22
6.2	stallGuard™ - sensorless motor stall detection	22
6.2.1	stallGuard™ adjusting tool	23
6.2.2	stallGuard™ profiler	23
6.3	Microstep resolution	24
7	TMC351 operational description	25
7.1	Calculation: Velocity and acceleration vs. microstep and fullstep frequency	25
8	TMCL™	27
9	CANopen	28
10	Revision history	29
10.1	Document revision	29
10.2	Hardware revision	29
11	References	30

1 Life support policy

TRINAMIC Motion Control GmbH & Co. KG does not authorize or warrant any of its products for use in life support systems, without the specific written consent of TRINAMIC Motion Control GmbH & Co. KG.

Life support systems are equipment intended to support or sustain life, and whose failure to perform, when properly used in accordance with instructions provided, can be reasonably expected to result in personal injury or death.

© TRINAMIC Motion Control GmbH & Co. KG 2011

Information given in this data sheet is believed to be accurate and reliable. However neither responsibility is assumed for the consequences of its use nor for any infringement of patents or other rights of third parties, which may result from its use.

Specifications are subject to change without notice.



2 Features

The TMC351 is a powerful three axes bipolar stepper motor controller/driver board with encoder interface for all three axes and a large number of general purpose digital and analog input/outputs. Several different serial communication interfaces are available.

Electrical data

- Supply voltage: +24V DC nominal (28.5V DC max.)
- Motor current: up to 2.8A RMS per axis (programmable)

Stepper motor data

- two phase bipolar stepper motors with up to 2.8A RMS coil current (e.g. QSH5718 or QSH6018)
- optional incremental encoder interface (a/b/n), accepts differential or single ended input signals

Interfaces

- reference switch inputs per motor axis (6 altogether, internal pull-up resistors, +24V compatible)
- 8 general purpose inputs (+24V compatible)
- 8 general purpose outputs incl. two power outputs (all open-collector)
- 1 shutdown input (enable/disable driver stage in hardware)
- dedicated analog inputs (programmable 3.3V/10V input range)
- SPI connector with three chip select signals for I/O extension
- Encoder interface (based on TMC423)
- RS232 interface
- RS485 interface
- CAN interface
- USB interface

Features

- High-efficient operation, low power-dissipation (TMC249 stepper driver with external MOSFETs)
- Dynamic current control
- Integrated Protection
- On the fly alteration of motor parameters (e.g. position, velocity, acceleration)
- Motion profile calculation in real-time (TMC428 motion controller)
- Each axis individually and independently programmable
- Supports up to 64 microsteps per fullstep
- Integrated stallGuard™ for motor stall detection (e.g. elimination of end switches)
- Closed-loop operation with TMCL™ possible (when using the optional incremental encoder interface)

Software

- TMCL™ remote (direct mode) or stand-alone operation (memory for 2048 TMCL™ commands)
- Fully supported by TMCL-IDE (PC based integrated development environment)
- Optional CANopen firmware

3 Order codes

The TMCM-351 is available with encoder interface and with standard TMCL™ firmware or CANopen firmware.

Order code	Description	Dimensions
TMCM-351-E	TMCM-351 with encoder interface and TMCL™ firmware	160 x 100 x 29 mm ³
TMCM-351-E-CANopen	TMCM-351 with encoder interface and CANopen firmware	160 x 100 x 29 mm ³
Related motors:		
QSH5718	57mm/NEMA23, 1.8° step angle	57.2 x 57.2 x 41/55/ 78.5 mm
QSH6018	60mm/NEMA24, 1.8° step angle	60.5 x 60.5 x 45/56/ 65/86 mm

Table 3.1: Order codes

Please note, that The TMCM-351 without Encoder interface is discontinued.

4 Mechanical and electrical interfacing

4.1 Dimensions

The TCMC-351 three axes controller driver board has a board size of 160mm x 100mm (standard euro board format). There are four mounting holes altogether for M3 screws placed at a distance of 4mm from each corner of the board (Figure 4.1). The high measures 29mm.

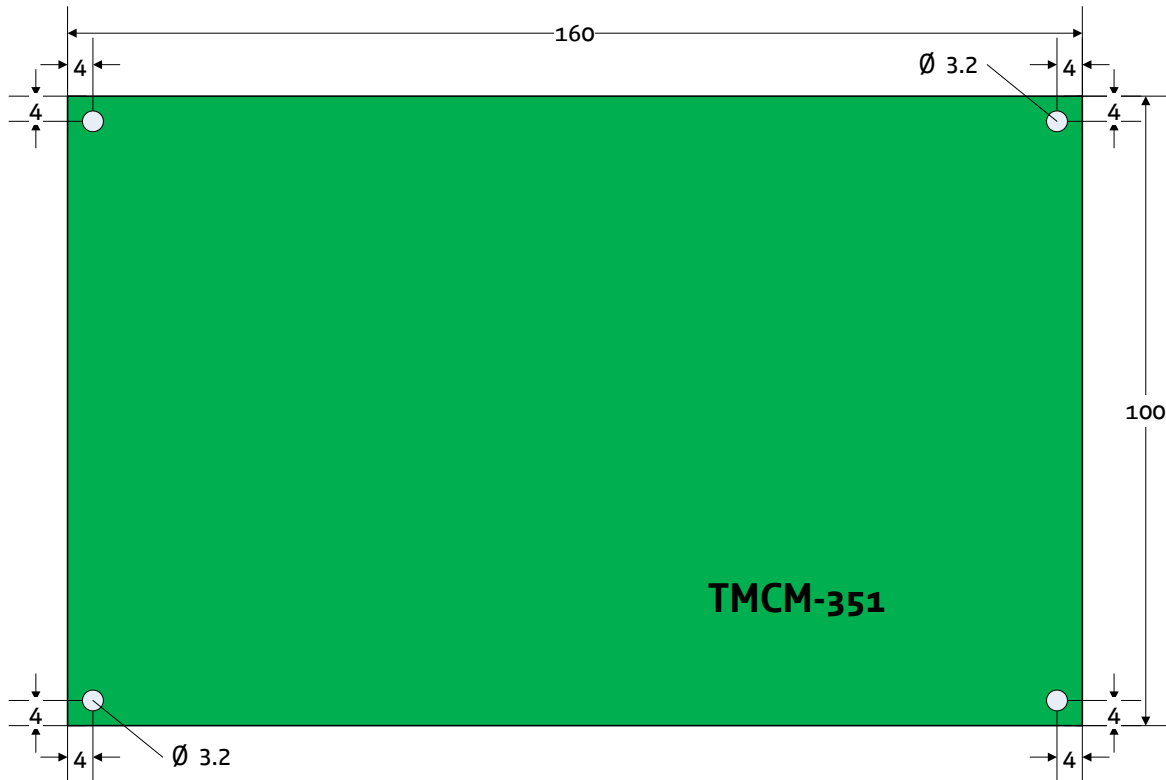


Figure 4.1: Dimensions of TCMC-351

4.2 Connectors

The TMC351 has connectors for three motors, related reference switches, three encoders, analog and digital inputs and outputs and several serial interfaces (RS232, RS485, CAN and USB). On the next page you will find a table with all connector types and their mating ones.

The TMC351 TMCL™ Firmware Manual (see www.trinamic.com) includes a section about putting the TMC351 into operation. Please refer to this manual, too.

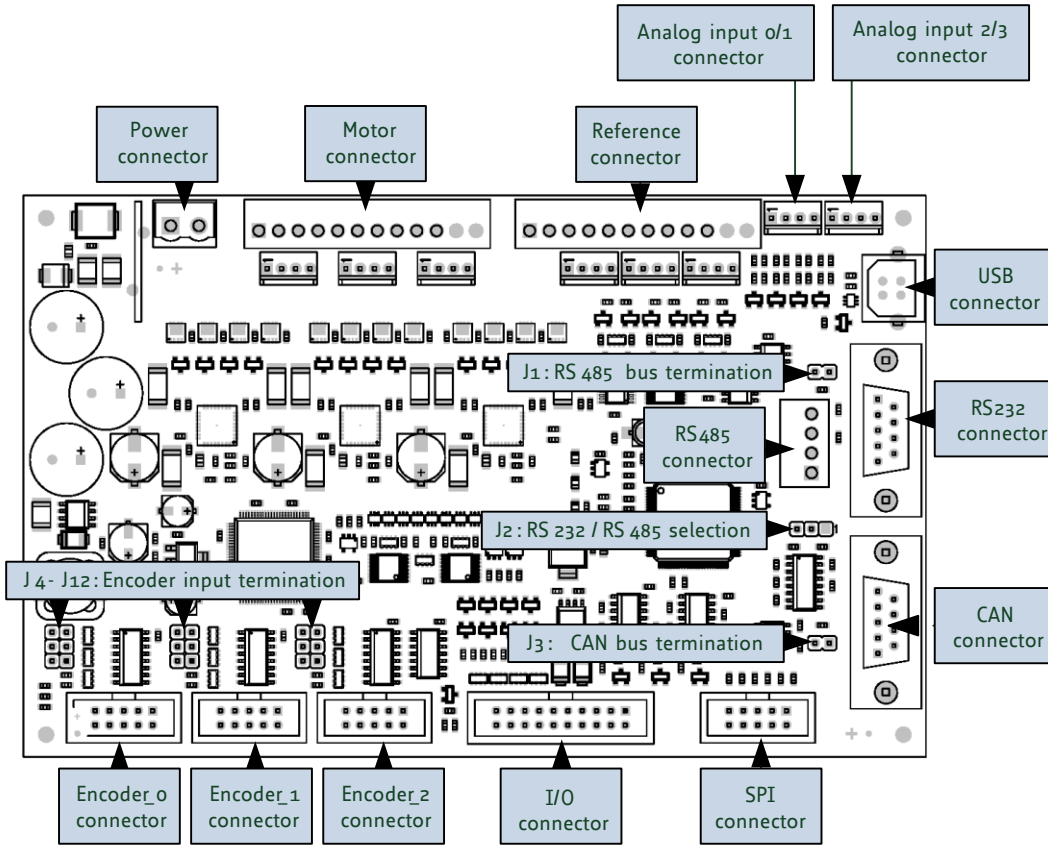


Figure 4.2: Connectors of TMC351

The following table shows which connector types and their mating connectors are used.

Domain	Connector type	Mating connector type
Power	RIA type 320, 2 pol., grid dimension 5	RIA type 349, 2 poles, grid dimension 5
Motor	RIA type 183, 12 pol., grid dimension 3.5	RIA type 169, 12 pol., grid dimension 3.5
	MOLEX type 6410, 2.54 mm KK header, vertical friction lock	MOLEX type 2045, 2.54 mm crimp housing, receptacle, 4 pol.
Reference	RIA type 183, 12 pol., grid dimension 3.5	RIA type 169, 12 pol., grid dimension 3.5
	MOLEX type 6410, 2.54 mm KK header, 4 pol., vertical friction lock	MOLEX type 2045, 2.54 mm crimp housing, receptacle, 4 pol.
Analog input	MOLEX type 6410, 2.54 mm KK header, vertical friction lock	MOLEX type 2045, 2.54 mm crimp housing, receptacle, 4 pol.
USB	USB, type B, 4 pol., vertical, female	USB, type B, 4 pol., male
RS232	DSUB, vertical, 9 pol., female	DSUB, 9 pol., male
CAN	DSUB, vertical, 9 pol., male	DSUB, 9 pol., female
SPI	low profile box header without locking bar, type 8289, 10 pol., DIN 41651, 2.54 (AVX 00 8380 010 000 01 0)	low profile IDC socket connector, 10pol., DIN41651, 2.54 (AVX 00 8290 010 001 01 1)
I/O	low profile box header without locking bar, type 8380, 20 pol., DIN 41651, 2.54 (AVX 00 8380 020 000 01 0)	low profile IDC socket connector, 20pol., DIN41651, 2.54 (AVX 00 8290 020 001 01 1)
Encoder	low profile box header without locking bar, type 8289, 10 pol., DIN 41651, 2.54 (AVX 00 8380 010 000 01 0)	low profile IDC socket connector, 10pol., DIN41651, 2.54 (AVX 00 8290 010 001 01 1)

Table 4.1: Connectors and mating connectors of the TMCM-351

4.2.1 Power connector

A 2-pin detachable screw connector is used for power supply.

Please connect the power as shown below:


	Pin	Label	Description
	1	GND	Module ground (power supply and signal ground)
	2	VDD	Power supply input, nom. +24V DC (+7... +28.5V DC)

Table 4.2: Power connector

4.2.2 Motor connector

For the three motors there are two connector options: either one detachable screw connector (for prototyping, smaller series) or three separate crimp connectors (for higher volume series).

Please connect your motors as shown below:


	Pin	Label	Description
	1	Motor_0_B-	Motor 0, coil B
	2	Motor_0_B+	Motor 0, coil B
	3	Motor_0_A-	Motor 0, coil A
	4	Motor_0_A+	Motor 0, coil A
	5	Motor_1_B-	Motor 1, coil B
	6	Motor_1_B+	Motor 1, coil B
	7	Motor_1_A-	Motor 1, coil A
	8	Motor_1_A+	Motor 1, coil A
	9	Motor_2_B-	Motor 2, coil B
	10	Motor_2_B+	Motor 2, coil B
	11	Motor_2_A-	Motor 2, coil A
12	Motor_2_A+	Motor 2, coil A	

Table 4.3: Motor connector (detachable screw connector)

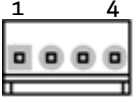
	Pin	Label	Description
	1	Motor_0/1/2_B-	Motor 0/1/2, coil B
	2	Motor_0/1/2_B+	Motor 0/1/2, coil B
	4	Motor_0/1/2_A+	Motor 0/1/2, coil A

Table 4.4: Motor connector (crimp connector)

4.2.3 Reference connector

For the reference switch inputs (two reference switch inputs are supported for each motor) there are two connector options: either one detachable screw connector (for prototyping, smaller series) or three separate crimp connectors (for higher volume series).

Please connect as follows:

Pin	Label	Description
1	REF_o_R	Motor 0, right reference / stop switch input
2	REF_o_L	Motor 0, left reference / stop switch input
3	GND	System / module ground
4	+5V	+5V supply output for active switches
5	REF_1_R	Motor 1, right reference / stop switch input
6	REF_1_L	Motor 1, left reference / stop switch input
7	GND	System / module ground
8	+5V	+5V supply output for active switches
9	REF_2_R	Motor 1, right reference / stop switch input
10	REF_2_L	Motor 1, left reference / stop switch input
11	GND	System / module ground
12	+5V	+5V supply output for active switches

Table 4.5: Reference connector (detachable screw connector)

Pin	Label	Description
1	REF_o/1/2_R	Motor 0/1/2, right reference / stop switch input
2	REF_o/1/2_L	Motor 0/1/2, left reference / stop switch input
3	GND	System / module ground
4	+5V	+5V supply output for active switches

Table 4.6: Reference connector (crimp connector)

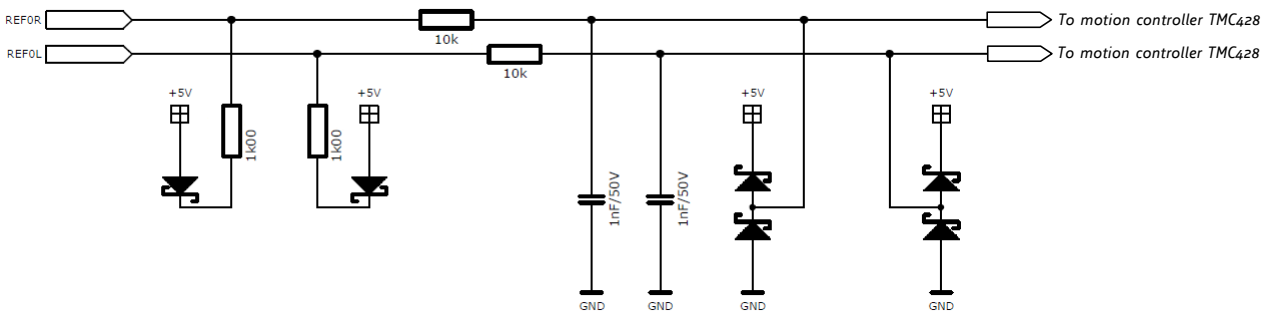


Figure 4.3: Internal Reference connector circuit (for one motor axis)

4.2.3.1 Left and right limit switches

The TMCM-351 can be configured so that a motor has a left and a right limit switch (Figure 4.4).

The motor stops when the traveler has reached one of the limit switches.

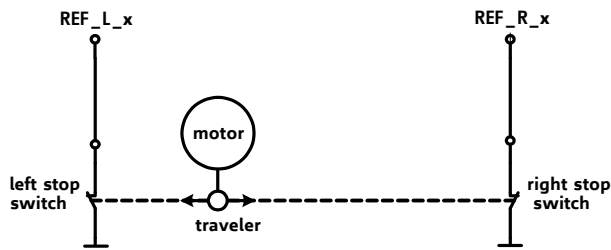


Figure 4.4: Left and right limit switches

4.2.3.2 Triple switch configuration

It is possible to program a tolerance range around the reference switch position. This is useful for a triple switch configuration, as outlined in Figure 4.5. In that configuration two switches are used as automatic stop switches, and one additional switch is used as the reference switch between the left stop switch and the right stop switch. The left stop switch and the reference switch are wired together. The center switch (travel switch) allows for a monitoring of the axis in order to detect a step loss.

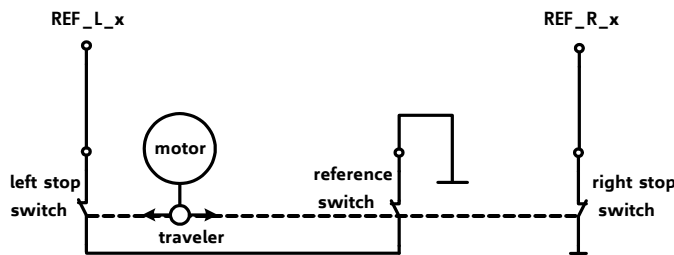


Figure 4.5: Limit switch and reference switch

4.2.3.3 One limit switch for circular systems

If a circular system is used (Figure 4.6), only one reference switch is necessary, because there are no end-points in such a system.

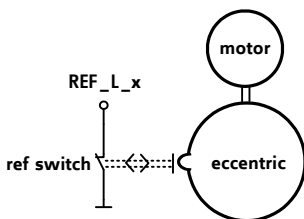


Figure 4.6: One reference switch

4.2.4 Analog input connector

The board has four dedicated analog inputs with programmable input range (0... +3.3V or 0... +10V). There are two connectors with two analog inputs connected to each connector

Please connect as shown below:

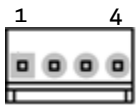
	Pin	Label	Description
	1	Analog_o/2	Analog input o/2
	2	GND	System / module ground
	3	Analog_1/3	Analog input 1/3
	4	GND	System / module ground

Table 4.7: Analog input connector

4.2.5 USB connector

The board includes an USB interface for serial communication. A standard USB type B connector is used for this purpose. USB is one out of four different interfaces available for communication with the board.

Please connect the USB interface with the enclosed cable as follows:

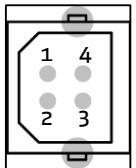
	Pin	Label	Description
	1	+5V	Board is self-powered – just use to detect availability of attached host system (e.g. PC)
	2	USB-	Differential USB bus
	3	USB+	Differential USB bus
	4	GND	System / module ground

Table 4.8: USB connector

4.2.6 RS232 connector

The board includes an RS232 interface for serial communication. A standard DSUB 9-pin female connector is used for this purpose. RS232 is one out of four different interfaces available for communication with the board.

Please connect as shown below:

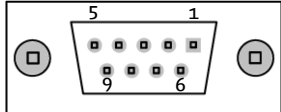
	Pin	Label	Description
	2	RS232_TxD	RS232 transmit serial data
	3	RS232_RxD	RS232 receive serial data
	5	GND	System / board ground
	1, 4, 6, 7, 8, 9	n.c.	Pins not used / not connected

Table 4.9: RS232 connector

Attention: Please verify the setting of J2 (selection of RS232 or RS485 interface in section 4.3.2) for a proper operation of the RS232 connection.

4.2.7 CAN connector

The board includes a CAN interface for serial communication. A standard DSUB 9-pin male connector is used for this purpose. CAN is one out of four different interfaces available for communication with the board.

Please connect as shown below:

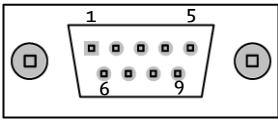
	Pin	Label	Description
	2	CAN_L	CAN differential bus
	7	CAN_H	CAN differential bus
	3, 6	GND	System / board ground
		n.c.	Pins not used / not connected

Table 4.10: CAN connector

Attention: Please verify the setting of J3 (CAN bus termination in section o) for a proper operation of the CAN connection.

4.2.8 RS485 connector

The board includes an RS485 interface for serial communication. A 4-pin detachable screw connector is used for this purpose. RS485 is one out of four different interfaces available for communication with the board.

Please connect as shown below:


	Pin	Label	Description
	1	RS485+	RS485 differential bus (connected to pin 3)
	2	RS485-	RS485 differential bus (connected to pin 4)
	3	RS485+	RS485 differential bus (connected to pin 1)
	4	RS285-	RS485 differential bus (connected to pin 2)

Table 4.11: RS485 connector

Attention: Please verify the settings of J1 (RS485 bus termination in section 4.3.1) and J2 (selection of RS232 or RS485 interface in section 4.3.2) for a proper operation of the RS485 connection.

4.2.9 SPI connector

For extension of the available inputs and outputs an SPI interface is available. A standard 2.54mm pitch two row header is used as connector for the external SPI interface.

Please connect as shown below:

	Pin	Label	Pin	Label
	1	SPI_MOSI	2	GND
	3	SPI_MISO	4	GND
	5	SPI_CLK	6	GND
	7	SPI_SEL0	8	SPI_SEL2
	9	SPI_SEL1	10	+5V_output

Table 4.12: SPI connector

4.2.10 I/O connector

The I/O connector offers 8 digital and analog inputs and 8 digital outputs. All inputs are +24V compatible. All outputs offer open collector driver stages. OUT_0/1/2/3/4/5 can sink up to 100mA, OUT_6/7 are more powerful and can drive up to 2A. A standard 2.54mm pitch two row header is used for this connector (refer to Figure 4.8 please).

Please connect the I/Os as follows:

Pin	Label	Pin	Label
1	OUT_0	2	OUT_1
3	OUT_2	4	OUT_3
5	OUT_4	6	OUT_5
7	OUT_6	8	OUT_7
9	+5V_output	10	GND
11	IN_0	12	IN_1
13	IN_2	14	IN_3
15	IN_4	16	IN_5
17	IN_6	18	IN_7
19	/Shutdown*	20	VDD

Table 4.13: I/O connector

* The /Shutdown input pin has to be connected to the supply voltage in order to enable the driver stages for all three stepper motor axes. A jumper between pin 19 and pin 20 can be used to permanently enable drivers (please refer to section 4.3.5 for detailed information).

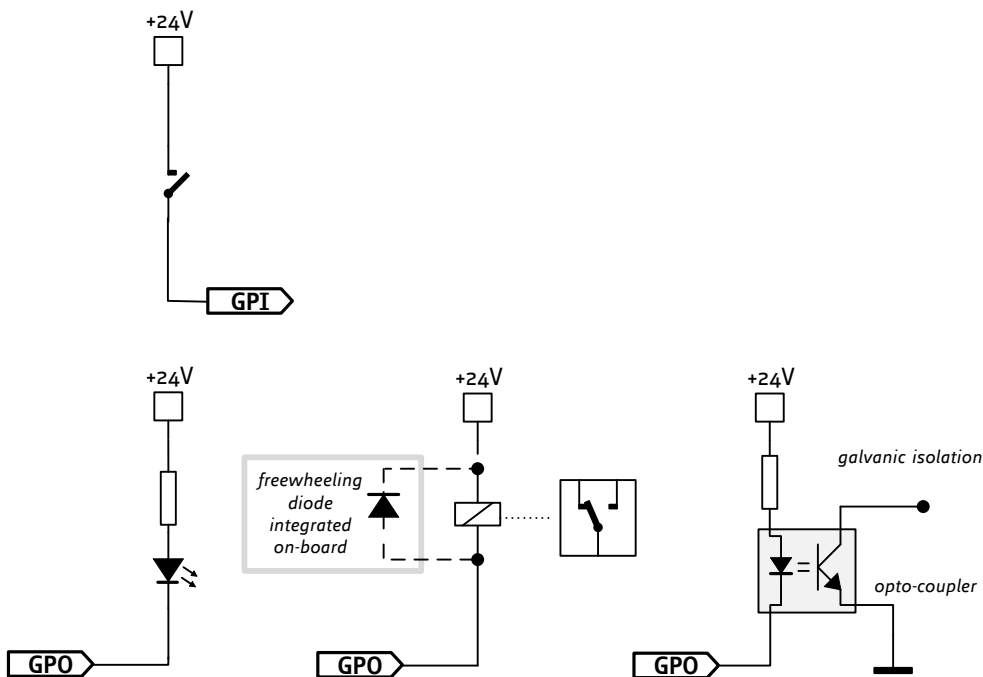


Figure 4.7: Examples for possible wirings for GPI and GPO

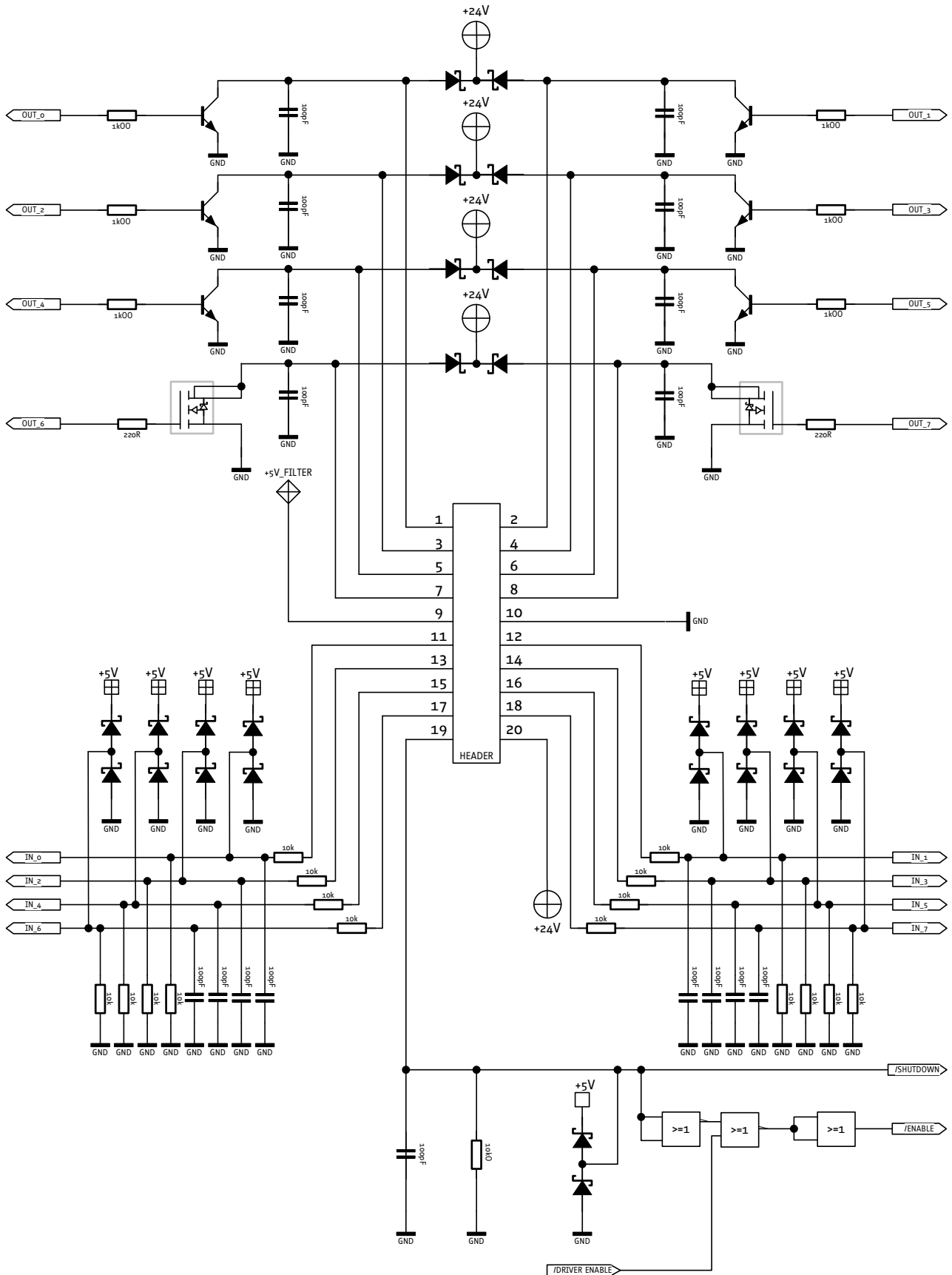


Figure 4.8: Internal I/O connector circuit

4.2.11 Encoder_o/1/2 connector

Three connectors (one encoder interface connector per axis) are available. A standard 2.54mm pitch two row header is used for connecting an encoder. Differential and single ended incremental encoders with/without zero/index channel are supported.

Please connect as follows:

Single ended encoder:

- GND to pin 1 and/or 2
- +5V to pin 7 and/or 8
- A to pin 5
- N to pin 3
- B to pin 9

Differential encoder:

- GND to pin 1 and/or 2
- +5V to pin 7 and/or 8
- A+ to pin 5, A- to pin 6
- N+ to pin 3, N- to pin 4
- B+ to pin 9, B- to pin 10

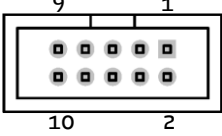
	Pin	Label	Pin	Label
	1	GND	2	GND
	3	Encoder_o/1/2_N+	4	Encoder_o/1/2_N-
	5	Encoder_o/1/2_A+	6	Encoder_o/1/2_A-
	7	+5V_output	8	+5V_output
	9	Encoder_o/1/2_B+	10	Encoder_o/1/2_B-

Table 4.13: Encoder connector

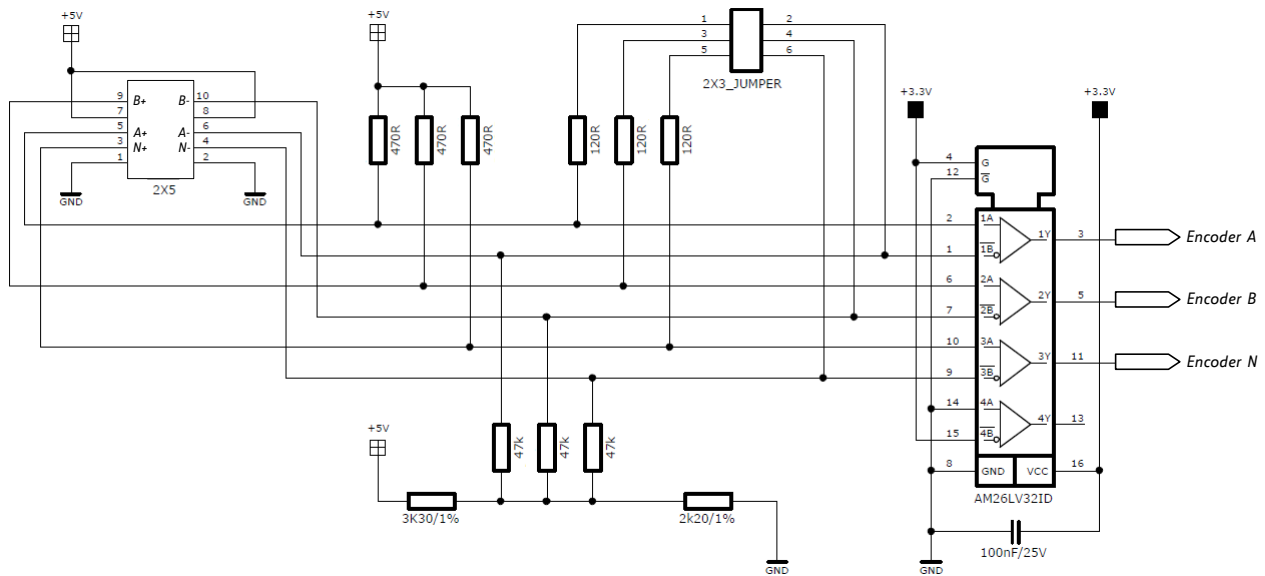


Figure 4.9: Internal encoder connector circuit (for one encoder connector)

4.3 Jumpers

Most settings of the board are done through the software. Nevertheless, a few jumpers are available for configuration.

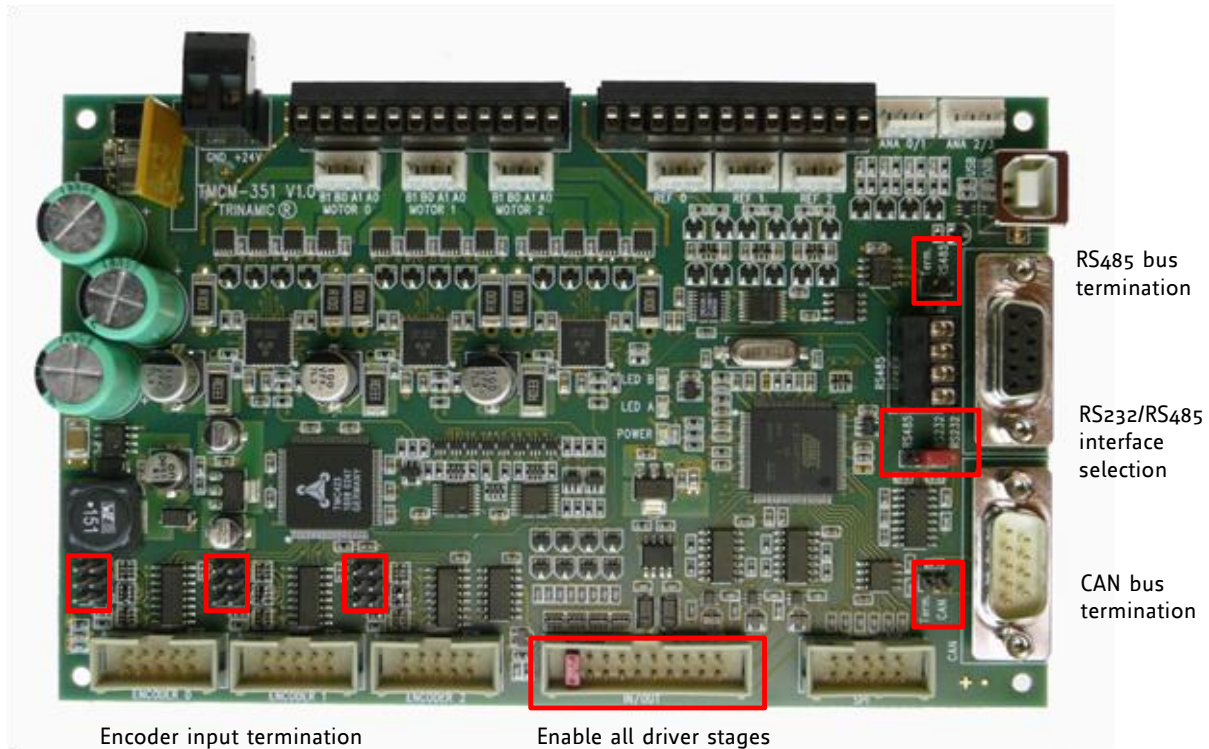


Figure 4.10: Configuration with jumpers

4.3.1 J1: RS485 bus termination

The board includes a 120 Ohm resistor for proper bus termination of the RS485 interface. When this jumper is closed, the resistor will be placed between the two differential bus lines RS485+ and RS485-.

4.3.2 J2: RS232 / RS485 interface selection

This 3-pin single row header is used for selecting one of two desired serial interfaces: RS232 or RS485 using a jumper:

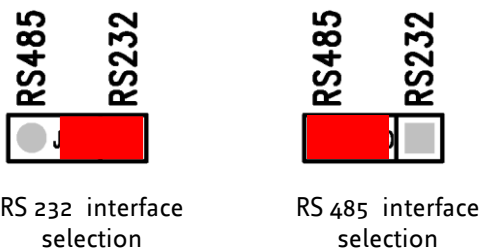


Figure 4.11: RS232/RS485 interface selection

4.3.3 J3: CAN bus termination

The board includes a 120 Ohm resistor for proper bus termination of the CAN interface. When this jumper is closed, the resistor will be placed between the two differential bus lines CAN_H and CAN_L.

4.3.4 J4 – J12: Encoder input termination

For enhanced reliability differential encoder signals should be terminated properly. The board offers termination resistors (120 Ohm) for all three encoder interface signals (a/b/n) for all three encoders. By setting jumpers, these resistors will be placed between the differential encoder signals. Do not set these jumpers in case encoders with single ended signals are used.

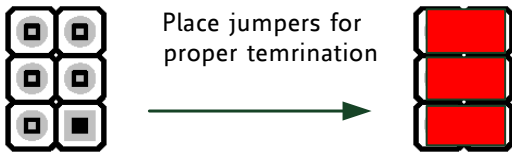


Figure 4.12: Encoder input termination

4.3.5 Enable all driver stages permanently

The /Shutdown input pin has to be connected to the supply voltage in order to enable the driver stages for all three stepper motor axes. A jumper between pin 19 and pin 20 can be used to permanently enable drivers.

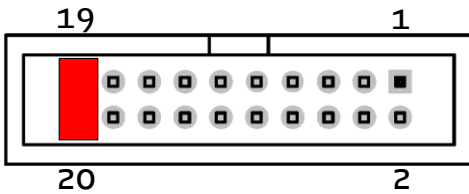


Figure 4.13: Enable all driver stages permanently

5 Operational Ratings

The operational ratings shown below should be used as design values. In no case should the maximum values been exceeded during operation.

Symbol	Parameter	Min	Typ	Max	Unit
V_{DD}	Power supply voltage for operation	7	24	28.5	V
I_{COIL_peak}	Motor coil current for sine wave peak (chopper regulated, adjustable via software)	0		4	A
I_{COIL_RMS}	Continuous motor current (RMS)	0		2.8	A
I_{SUPPLY}	Power supply current		$\ll I_{COIL}$	$1.4 * I_{COIL}$	A
I_{+5V_OUTPUT}	Current available from on-board +5V output (e.g. via Encoder connector o/1/2, Reference connector etc.) for external devices, e.g. encoder supply, reference switches etc. Summarized for all +5V connections together.			300	mA
T_{ENV}	Environment temperature at rated current (no forced cooling required)	-20		+40 *)	°C
	Environment temperature at 80% of rated current or 50% duty cycle (no forced cooling required)	-20		+60 **)	°C

Table 5.1: General operational ratings of the module

*) Please note: rated current of 2.8A RMS and 4A peak is reached with setting SAP 6, <motor>, 228 (see TMCM-351 TMCL™ firmware manual [TMCL]). Same value for CANopen firmware (see CANopen manual [CANopen])

***) Please note: tested with setting SAP 6, <motor>, 180 (see TMCM-351 TMCL™ firmware manual [TMCL]). Same value for CANopen firmware (see CANopen manual [CANopen])

Symbol	Parameter	Min	Typ	Max	Unit
$V_{REF_o/1/2_L/R}$	Input voltage for reference switch inputs REF_o/1/2_L and REF_o/1/2_R	0		28.5	V
$V_{REF_o/1/2_L/R_L}$	Low level voltage for reference switch inputs REF_o/1/2_L / REF_o/1/2_R	0		0.8	V
$V_{REF_o/1/2_L/R_H}$	High level voltage for reference switch inputs REF_o/1/2_L / REF_o/1/2_R	2.0		28.5	V

Table 5.2: Operational ratings of the reference switch inputs

Symbol	Parameter	Min	Typ	Max	Unit
V _{OUT_o..7}	Voltage at open collector / open drain output	0		V _{DD}	V
I _{OUT_o1/2/3/4/5}	Output sink current for OUT_o1/2/3/4/5			100	mA
I _{OUT_6/7}	Output sink current for OUT_6 and OUT_7			1	A
V _{IN_o1/2/3/4/5/6/7}	Input voltage for general purpose digital inputs IN_o1/2/3/4/5/6/7	0		28.5	V
V _{IN_o1/2/3/4/5/6/7_L}	Low level voltage for general purpose digital inputs IN_1/2/3/4/5/6/7	0		1.6	V
V _{IN_o1/2/3/4/5/6/7_H}	High level voltage for general purpose digital inputs IN_1/2/3/4/5/6/7	4		28.5	V
V _{Analog_o1/2/3}	Full scale input voltage range for analog voltage inputs (programmable voltage divider switched off)	0		3.3	V
V _{Analog_o1/2/3}	Full scale input voltage range for analog voltage inputs (programmable voltage divider switched on)	0		10	V

Table 5.3: Operational ratings of the general purpose digital I/Os and dedicated analog inputs

Symbol	Parameter	Min	Typ	Max	Unit
N _{RS485}	Number of nodes connected to single RS485 network			256*)	

Table 5.4: Operational ratings of the RS485 interface

Symbol	Parameter	Min	Typ	Max	Unit
N _{CAN}	Number of nodes connected to single CAN network		110*)		

Table 5.5: Operational ratings of the CAN interface

*) Number of nodes per CAN or RS485 network highly depends on communication speed and cable length. Higher speeds and longer cables will reduce max. feasible number of nodes in one network.

6 Functional description

In figure 6.1 the main parts of the TCM351 are shown. The module mainly consists of the μC (connected to the EEPROM TMCL™ memory), the TMC428 motion controller (which controls up to three axes), three TMC249 stepper drivers, three external MOSFETs, the interfaces (RS232, RS485, USB, and CAN), I/Os, and the encoder interface based on the TMC423.

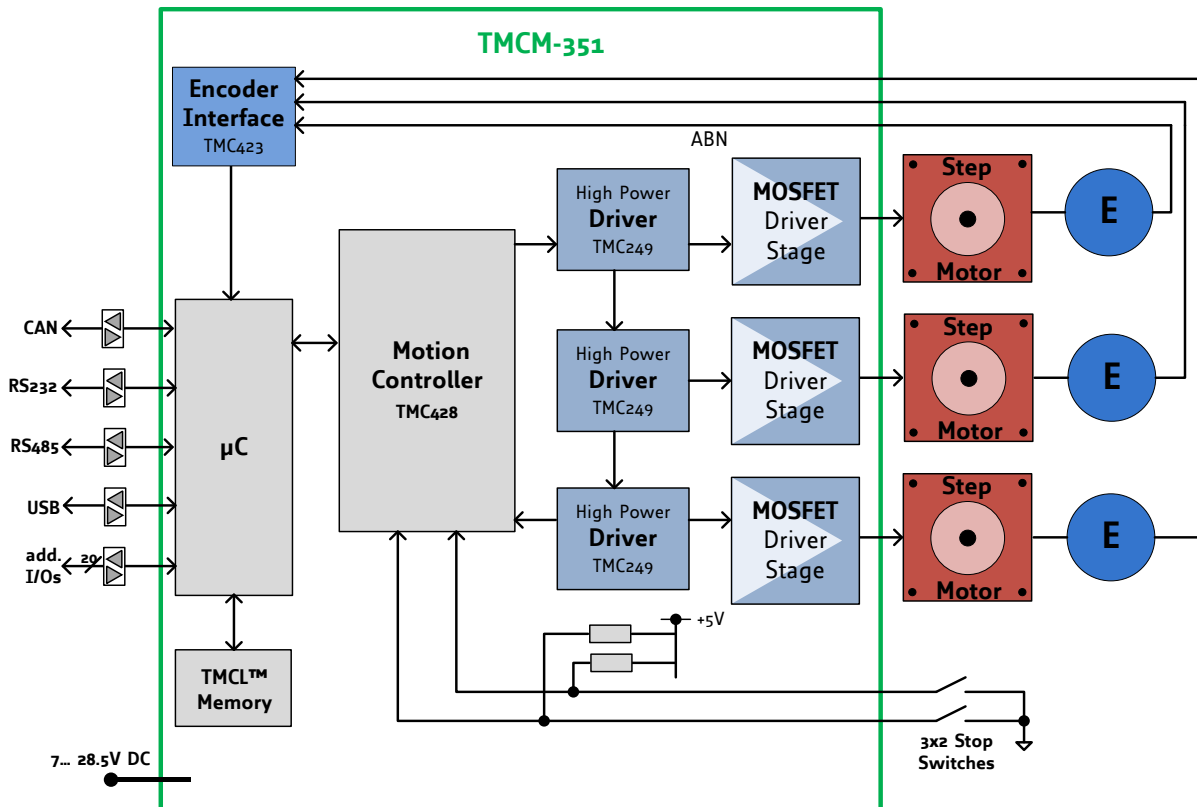


Figure 6.1: Main parts of the TCM351

6.1 System architecture

The TCM351 integrates a microcontroller with the TMCL™ (Trinamic Motion Control Language) operating system. The motion control real-time tasks are realized by the TMC428.

6.1.1 Microcontroller

On this module, the Atmel AT91SAM7X256 is used to run the TMCL™ operating system and to control the TMC428. The CPU has 256KB flash memory and a 64KB RAM. The microcontroller runs the TMCL™ (Trinamic Motion Control Language) operating system which makes it possible to execute TMCL™ commands that are sent to the module from the host via the RS232, RS485, USB, or CAN interface. The microcontroller interprets the TMCL™ commands and controls the TMC428 which executes the motion commands. In addition it is connected with the encoder interface and processes the inputs.

The flash ROM of the microcontroller holds the TMCL™ operating system. The TMCL™ operating system can be updated via the RS232 interface or via the CAN interface. Use the TMCL-IDE to do this.

6.1.2 EEPROM

To store TMCL™ programs for stand-alone operation the TMCM-351 module is equipped with a 16kByte EEPROM attached to the microcontroller. The EEPROM can store TMCL™ programs consisting of up to 2048 TMCL™ commands. The EEPROM is also used to store configuration data.

6.1.3 TMC428 motion controller

The TMC428 is a high-performance stepper motor control IC and can control up to three 2-phase-stepper-motors. Motion parameters like speed or acceleration are sent to the TMC428 via SPI by the microcontroller. Calculation of ramps and speed profiles are done internally by hardware based on the target motion parameters.

6.1.4 Stepper motor drivers

On the TMCM-351 modules the TMC249 chips are used. These chips have the stallGuard™ feature. As the power dissipation of TMC249 chips is very low no heat sink or cooling fan is needed. The temperature of the chips does not get high. The coils will be switched off automatically when the temperature or the current exceeds the limits and automatically switched on again when the values are within the limits again.

The TMCM-351 module is equipped with a circuit that extends the microstep resolution of the TMC249 chips to true 64 times microstepping. The maximum peak coil current of each stepper motor driver chip is 1500mA.

6.2 stallGuard™ - sensorless motor stall detection

The TMCM-343 modules are equipped with the stallGuard™ feature. The stallGuard™ feature makes it possible to detect if the mechanical load on a stepper motor is too high or if the traveler has been obstructed. The load value can be read using a TMCL™ command or the module can be programmed so that the motor will be stopped automatically when it has been obstructed or the load has been too high.

stallGuard™ can also be used for finding the reference position without the need for a reference switch: Activate stallGuard™ and then let the traveler run against a mechanical obstacle that is placed at the end of the way. When the motor has stopped it is definitely at the end of its way, and this point can be used as the reference position.

For using stallGuard™ in an actual application, some manual tests should be done first, because the stallGuard™ level depends upon the motor velocities and on the occurrence of resonances.

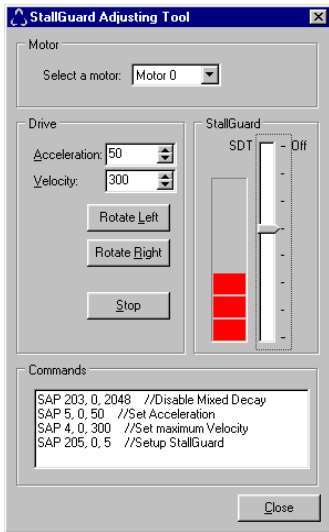
Mixed decay should be switched off while stallGuard™ is in use in order to get usable results.

Value	Description
0	stallGuard™ function is deactivated (default)
1... 7	Motor stops when stallGuard™ value is reached and position is not set zero.

Table 6.1: stallGuard™ parameter SAP 205

To activate the stallGuard™ feature use the TMCL™ command SAP 205 and set the stallGuard™ threshold value according to Table 6.1. The actual load value is given by GAP 206. The TMCL-IDE has some tools which let you try out and adjust the stallGuard™ function in an easy way. They can be found at *stallGuard™* in the *Setup* menu and are described in the following chapters. Please refer to the TMCM-341/342/343 TMCL™ Firmware Manual for further information about working with TMCL-IDE.

6.2.1 stallGuard™ adjusting tool



The stallGuard™ adjusting tool helps to find the necessary motor parameters when stallGuard™ is to be used. This function can only be used when a module is connected that features stallGuard™. This is checked when the stallGuard™ adjusting tool is selected in the *Setup* menu. After this has been successfully checked the stallGuard™ adjusting tool is displayed.

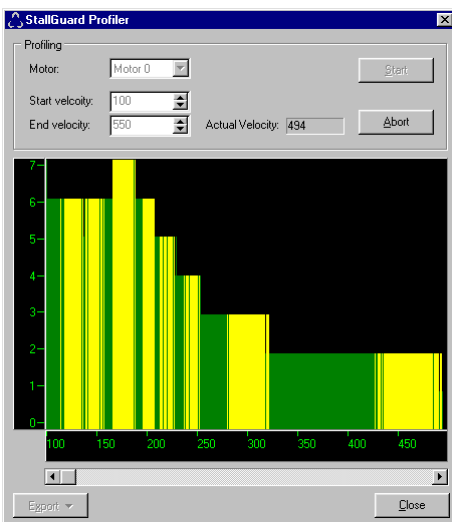
First, select the axis that is to be used in the *Motor* area. Now you can enter a velocity and an acceleration value in the *Drive* area and then click *Rotate Left* or *Rotate Right*. Clicking one of these buttons will send the necessary commands to the module so that the motor starts running. The red bar in the *stallGuard™* area on the right side of the windows displays the actual load value. Use the slider to set the stallGuard™ threshold value. If the load value reaches this value the motor stops. Clicking the *Stop* button also stops the motor.

Figure 6.2: stallGuard™ adjusting tool

All commands necessary to set the values entered in this dialogue are displayed in the *Commands* area at the bottom of the window. There, they can be selected, copied and pasted into the TMCL™ editor.

6.2.2 stallGuard™ profiler

The stallGuard™ profiler is a utility that helps you find the best parameters for using stall detection. It scans through given velocities and shows which velocities are the best ones. Similar to the stallGuard™ adjusting tool it can only be used together with a module that supports stallGuard™. This is checked right after the stallGuard™ profiler has been selected in the *Setup* menu. After this has been successfully checked the stallGuard™ profiler window will be shown.



First, select the axis that is to be used. Then, enter the *Start velocity* and the *End velocity*. The start velocity is used at the beginning of the profile recording. The recording ends when the end velocity has been reached. Start velocity and end velocity must not be equal. After you have entered these parameters, click the *Start* button to start the stallGuard™ profile recording. Depending on the range between start and end velocity this can take several minutes, as the load value for every velocity value is measured ten times. The *Actual velocity* value shows the velocity that is currently being tested and so tells you the progress of the profile recording. You can also abort a profile recording by clicking the *Abort* button. The result can also be exported to Excel or to a text file by using the *Export* button.

Figure 6.3: The stallGuard™ profiler

6.2.2.1 The result of the stallGuard™ profiler

The result is shown as a graphic in the stallGuard™ profiler window. After the profile recording has finished you can scroll through the profile graphic using the scroll bar below it. The scale on the vertical axis shows the load value: A higher value means a higher load. The scale on the horizontal axis is the velocity scale. The color of each line shows the standard deviation of the ten load values that have been measured for the velocity at that point. This is an indicator for the vibration of the motor at the given velocity.

There are three colors used:

Green: The standard deviation is very low or zero. This means that there is effectively no vibration at this velocity.

Yellow: This color means that there might be some low vibration at this velocity.

Red: The red color means that there is high vibration at that velocity.

6.2.2.2 Interpreting the result

In order to make effective use of the stallGuard™ feature you should choose a velocity where the load value is as low as possible and where the color is green. The very best velocity values are those where the load value is zero (areas that do not show any green, yellow or red line). Velocities shown in yellow can also be used, but with care as they might cause problems (maybe the motor stops even if it is not stalled).

Velocities shown in red should not be chosen. Because of vibration the load value is often unpredictable and so not usable to produce good results when using stall detection.

As it is very seldom that exactly the same result is produced when recording a profile with the same parameters a second time, always two or more profiles should be recorded and compared against each other.

6.3 Microstep resolution

The TMCM-351 supports a true 64 microstep resolution. To meet your needs, the microstep resolution can be set using the TMCL™ software. The default setting is 64 microsteps, which is the highest resolution. For setting the microstep resolution with the TMCL™ firmware use instruction 5: SAP, type 140: microstep resolution.

You can find the appropriate value in Table 6.2.

Value	microsteps
0	Do not use. For fullstep please see fullstep threshold
1	2
2	4
3	8
4	16
5	32
6	64

Table 6.2: Microstep resolution setting

Please refer to the TMCM-351 TMCL™ Firmware Manual (www.trinamic.com) for more information.

7 TCM-351 operational description

7.1 Calculation: Velocity and acceleration vs. microstep and fullstep frequency

The values of the parameters sent to the TMC428 do not have typical motor values like rotations per second as velocity. But these values can be calculated from the TMC428-parameters as shown in this document.

The parameters for the TMC428 are:

Signal	Description	Range
f _{CLK}	clock-frequency	0... 16 MHz
velocity	-	0... 2047
a_max	maximum acceleration	0... 2047
pulse_div	divider for the velocity. The higher the value is, the less is the maximum velocity default value = 0	0... 13
ramp_div	divider for the acceleration. The higher the value is, the less is the maximum acceleration default value = 0	0... 13
Usrs	microstep-resolution (microsteps per fullstep = 2 ^{usrs})	0... 7 (a value of 7 is internally mapped to 6 by the TMC428)

Table 7.1: TMC428 velocity parameters

The **microstep-frequency** of the stepper motor is calculated with

$$usf[\text{Hz}] = \frac{f_{\text{CLK}}[\text{Hz}] \cdot \text{velocity}}{2^{\text{pulse_div}} \cdot 2048 \cdot 32} \quad \text{with usf: microstep-frequency}$$

To calculate the **fullstep-frequency** from the microstep-frequency, the microstep-frequency must be divided by the number of microsteps per fullstep.

$$fsf[\text{Hz}] = \frac{usf[\text{Hz}]}{2^{\text{usrs}}} \quad \text{with fsf: fullstep-frequency}$$

The change in the pulse rate per time unit (pulse frequency change per second – the **acceleration a**) is given by

$$a = \frac{f_{\text{CLK}}^2 \cdot a_{\text{max}}}{2^{\text{pulse_div} + \text{ramp_div} + 29}}$$

This results in acceleration in fullsteps of:

$$af = \frac{a}{2^{\text{usrs}}} \quad \text{with af: acceleration in fullsteps}$$

Example:

Signal	value
f_CLK	16 MHz
velocity	1000
a_max	1000
pulse_div	1
ramp_div	1
usrs	6

$$msf = \frac{16\text{MHz} \cdot 1000}{2^1 \cdot 2048 \cdot 32} = \underline{\underline{12207031\text{Hz}}}$$

$$fsf[\text{Hz}] = \frac{12207031}{2^6} = \underline{\underline{1907.34\text{Hz}}}$$

$$a = \frac{(16\text{MHz})^2 \cdot 1000}{2^{1+1+29}} = \underline{\underline{119.21 \frac{\text{MHz}}{\text{s}}}}$$

$$af = \frac{119.21 \frac{\text{MHz}}{\text{s}}}{2^6} = \underline{\underline{1.863 \frac{\text{MHz}}{\text{s}}}}$$

Calculation of the number of rotations:

A stepper motor has e.g. 72 fullsteps per rotation.

$$\text{RPS} = \frac{fsf}{\text{fullstepsperrotation}} = \frac{1907.34}{72} = 26.49$$

$$\text{RPM} = \frac{fsf \cdot 60}{\text{fullstepsperrotation}} = \frac{1907.34 \cdot 60}{72} = 1589.46$$

8 TMCL™

TMCL™, the TRINAMIC Motion Control Language, is described in separate documentations, which refer to the specific products (e.g. TMC351 TMCL™ Firmware Manual [TMCL]). The manuals are provided on the TMC TechLibCD and on www.trinamic.com. Please refer to these sources for updated data sheets and application notes.

The TMC TechLibCD includes data sheets, application notes, and schematics of evaluation boards, software of evaluation boards, source code examples, parameter calculation spreadsheets, tools, and more.

9 CANopen

The TMCM-351 module can also be used with the CANopen protocol. For this purpose, a special CANopen firmware has to be installed. To do that, download the latest version of the TMCM-351 CANopen firmware from the Trinamic website or use the version provided on the TechLib CD and install it using the firmware update function of the TMCL-IDE (Setup/Install OS). The TMCM-351 module is then ready to be used with CANopen. Please see the specific CANopen manual provided on the TRINAMIC website and on the TechLibCD on how to use the TMCM-351 module with the CANopen protocol.

10 Revision history

10.1 Document revision

Version	Date	Author	Description
1.00	2008-OCT-22	GE	Initial version
1.01	2009-MAY-25	OE	Encoder input pinning corrected
1.02	2010-MAY-05	SD	Functional and operational description added. More information about I/Os appended
1.03	2010-SEP-25	SD	Order codes renewed minor changes.
1.04	2011-APR-12	SD	Table of connector and mating connector types added. New front page
1.05	2011-NOV-04	GE	Operation ratings added
1.06	2011-NOV-14	GE	REF switch and encoder input circuits added

Table 10.1: Document revision

10.2 Hardware revision

Version	Date	Description
1.00	2008-AUG-25	First prototypes
1.10	2008-DEC-22	Series version
1.20	2009-DEC-14	New encoder interface IC

Table 10.2: Hardware revision

11 References

[TMCL]	TMC-351 TMCL™ Firmware Manual (see www.trinamic.com)
[CANopen]	TMC-351 / TMC-43x CANopen Manual (see www.trinamic.com)
[TMCL-IDE]	TMCL-IDE User Manual (see www.trinamic.com)
[QSH5718]	QSH5718 Manual (see www.trinamic.com)
[QSH6018]	QSH6018 Manual (see www.trinamic.com)