

Hardware Version V1.0

# HARDWARE MANUAL

+

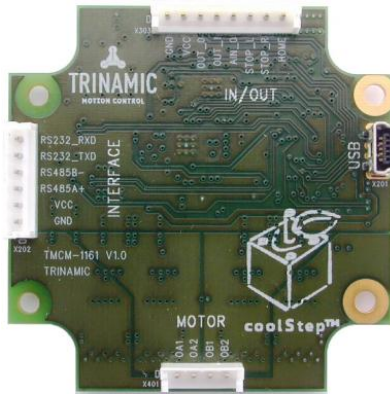

+

+

## TMCM-1161

1-axis Stepper  
Controller / Driver  
up to 2.8 RMS / 24V DC  
USB, RS485, and RS232

+

### UNIQUE FEATURES:



## stallGuard<sup>2</sup>

TRINAMIC Motion Control GmbH & Co. KG  
Hamburg, Germany

[www.trinamic.com](http://www.trinamic.com)

**TRINAMIC**  
MOTION CONTROL

# Table of Contents

1	Features.....	3
2	Order Codes .....	5
3	Mechanical and Electrical Interfacing.....	6
3.1	TMC1161 Dimensions and Mounting Holes.....	6
3.2	Connectors of TMC1161.....	7
3.2.1	Interface and Power Supply Connector .....	8
3.2.2	USB Connector .....	9
3.2.3	In/Out Connector.....	10
3.2.4	Motor Connector.....	11
4	Reset to Factory Defaults.....	12
5	On-board LEDs.....	13
6	Operational Ratings .....	14
7	Functional Description.....	15
8	TMC1161 Operational Description .....	16
8.1	Calculation: Velocity and Acceleration vs. Microstep and Fullstep Frequency.....	16
9	Life Support Policy.....	18
10	Revision History.....	19
10.1	Document Revision .....	19
10.2	Hardware Revision .....	19
11	References .....	19

# 1 Features

The TMC1161 is a single axis controller/driver module for 2-phase bipolar stepper motors with state of the art feature set. It is highly integrated, offers a convenient handling and can be used in many decentralized applications. The module can be mounted on the back of NEMA23 (57mm flange size) and NEMA24 (60mm flange size) stepper motors and has been designed for coil currents up to 2.8A RMS and 24V DC supply voltage. With its high energy efficiency from TRINAMIC's coolStep™ technology cost for power consumption is kept down. The TMCL™ firmware allows for both, standalone operation and direct mode.

## MAIN CHARACTERISTICS

### Motion controller

- Motion profile calculation in real-time
- On the fly alteration of motor parameters (e.g. position, velocity, acceleration)
- High performance microcontroller for overall system control and serial communication protocol handling

### Bipolar stepper motor driver

- Up to 256 microsteps per full step
- High-efficient operation, low power dissipation
- Dynamic current control
- Integrated protection
- stallGuard2 feature for stall detection
- coolStep feature for reduced power consumption and heat dissipation

### Encoder

- sensOstep magnetic encoder (max. 1024 increments per rotation) e.g. for step-loss detection under all operating conditions and positioning supervision

### Interfaces

- inputs for stop switches (left and right) and home switch
- 1 analog input
- 2 general purpose outputs (open collector with freewheeling diodes)
- USB, RS232, and RS485 communication interfaces

### Software

- TMCL: standalone operation or remote controlled operation, program memory (non volatile) for up to 2048 TMCL commands, and PC-based application development software TMCL-IDE available for free.

### Electrical and mechanical data

- Supply voltage: +24V DC nominal (10... 30V DC)
- Motor current: up to 2.8A RMS (programmable)

**Refer to separate TMCL Firmware Manual, too.**

## TRINAMICS UNIQUE FEATURES – EASY TO USE WITH TMCL

**stallGuard2™** stallGuard2 is a high-precision sensorless load measurement using the back EMF on the coils. It can be used for stall detection as well as other uses at loads below those which stall the motor. The stallGuard2 measurement value changes linearly over a wide range of load, velocity, and current settings. At maximum motor load, the value goes to zero or near to zero. This is the most energy-efficient point of operation for the motor.

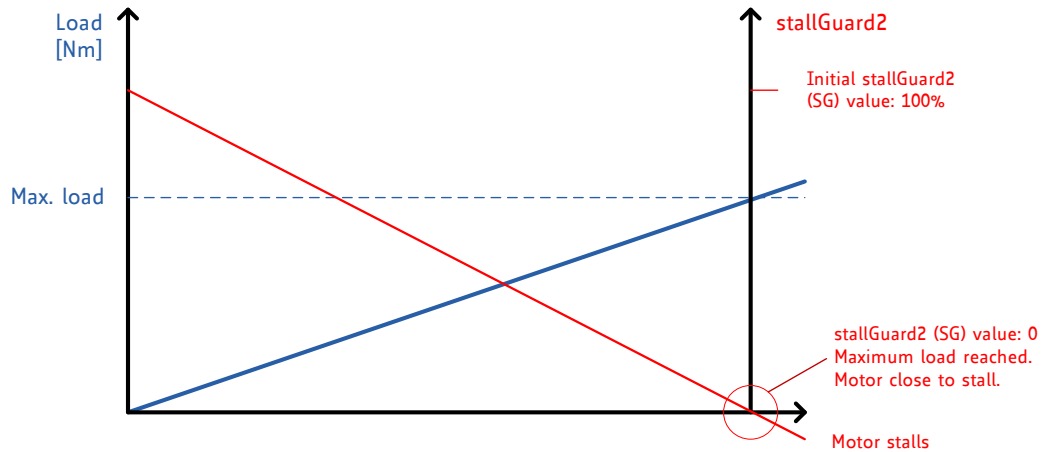

**Figure 1.1** stallGuard2 load measurement SG as a function of load

**coolStep™** coolStep is a load-adaptive automatic current scaling based on the load measurement via stallGuard2 adapting the required current to the load. Energy consumption can be reduced by as much as 75%. coolStep allows substantial energy savings, especially for motors which see varying loads or operate at a high duty cycle. Because a stepper motor application needs to work with a torque reserve of 30% to 50%, even a constant-load application allows significant energy savings because coolStep automatically enables torque reserve when required. Reducing power consumption keeps the system cooler, increases motor life, and allows reducing cost.

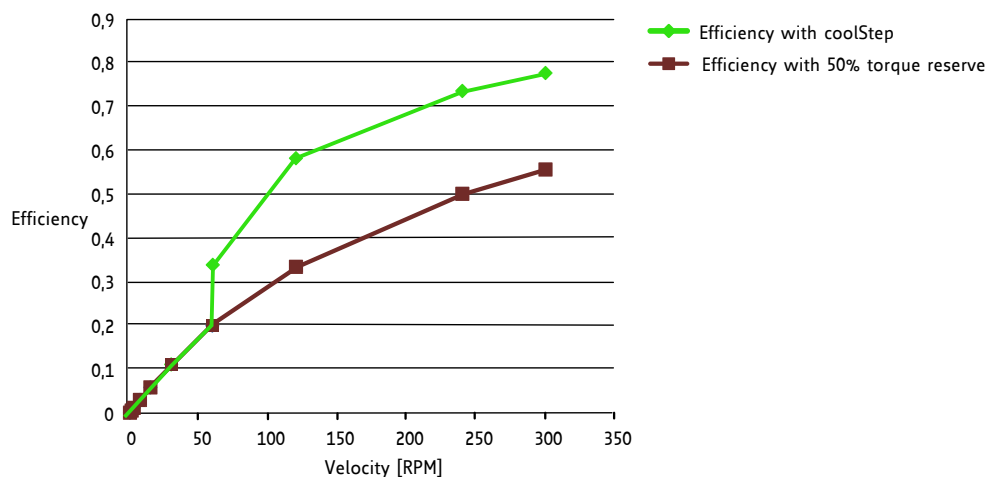

**Figure 1.2** Energy efficiency example with coolStep

## 2 Order Codes

Order code	Description	Size (mm <sup>3</sup> )
TMC-1161	Single axis bipolar stepper motor controller / driver electronics with integrated sensOstep encoder and coolStep feature	60 x 60 x 12

**Table 2.1: TMC-1161 order codes**

A cable loom set is available for this module:

Order code	Description
TMC-1161-CABLE	Cable loom for TMC-1161 <ul style="list-style-type: none"><li>- 1x cable loom for interface connector</li><li>- 1x cable loom for In/Out connector</li><li>- 1x cable loom for motor connector</li><li>- 1x USB type A connector to mini-USB type B connector cable</li></ul>

**Table 2.2 Cable loom order code**

*Please note that the TMC-1161 is available with NEMA23 and NEMA24 stepper motors, too. Please refer to the PD-1161 documents for more information about these products.*

## 3 Mechanical and Electrical Interfacing

### 3.1 TMC1161 Dimensions and Mounting Holes

The dimensions of the controller/driver board are approx. 60mm x 60mm x 12mm in order to fit on the back of a 60mm stepper motor. Maximum component height (height above PCB level) without mating connectors is around 8mm above PCB level and 2.5mm below PCB level. There are four mounting holes for M3 screws for mounting the board either to a NEMA23 (two mounting holes at opposite corners) or a NEMA24 (other two mounting holes at opposite corners) stepper motor.

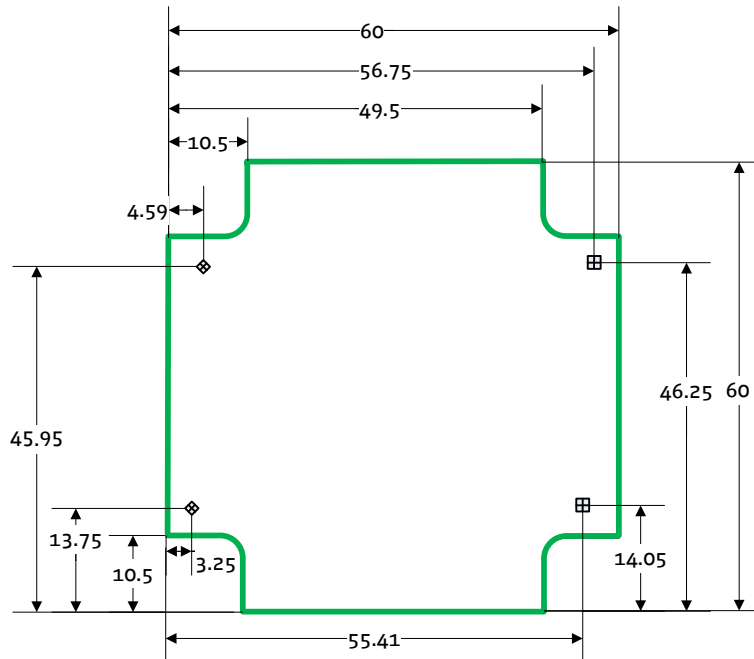

Figure 3.1: Dimensions of TMC1161 and position of mounting holes

### 3.2 Connectors of TMCM-1161

The TMCM-1161 offers four connectors including the motor connector which is used for attaching the motor coils to the electronics. There are two connectors for serial communication (one for USB and one for RS232/RS485) and one connector for I/O signals and switches.

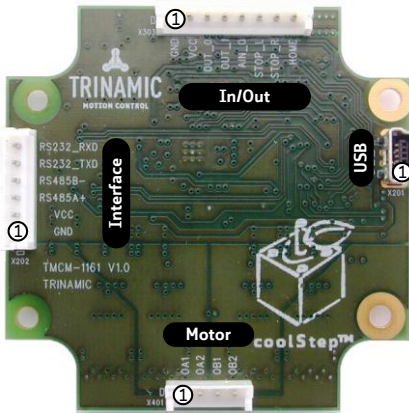

Figure 3.2 Overview connectors

Domain	Connector type	Mating connector type
Interface / Power	JST B6B-EH-A, 2.5mm pitch connector header, vertical	JST EHR-6, female crimp connector housing; crimp contacts JST SEH-001T-P0.6
Motor	JST B4B-EH-A, 2.5mm pitch connector header, vertical	JST EHR-4, female crimp connector housing; crimp contacts JST SEH-001T-P0.6
In/Out	JST B8B-EH-A, 2.5mm pitch connector header, vertical	JST EHR-8, female crimp connector housing; crimp contacts JST SEH-001T-P0.6
USB	Mini-USB type B vertical female	Mini-USB type B, male

## 3.2.1 Interface and Power Supply Connector

Pin	Label	Description
1	GND	Module and signal ground
2	VCC	10... 30V DC power supply / nom. 24V DC
3	RS485A+	RS485 non-inverted bus signal
4	RS485B-	RS485 inverted bus signal
5	RS232_TxD	RS232 transmit data from module
6	RS232_RxD	RS232 receive data to module

**Table 3.1 Connector for power supply and interfaces**

### 3.2.1.1 Power Supply

When using supply voltages near the upper limit, a regulated power supply is mandatory. Please ensure, that enough power filtering capacitors are available in the system (2200 $\mu$ F or more recommended) in order to absorb mechanical energy fed back by the motor in stalling conditions.

The power supply should be designed in a way, that it supplies the nominal motor voltage at the desired maximum motor power.

To ensure reliable operation of the unit, the power supply has to have a sufficient output capacitor and the supply cables should have a low resistance, so that the chopper operation does not lead to an increased power supply ripple directly at the unit. Power supply ripple due to the chopper operation should be kept at a maximum of a few 100mV.

#### Guidelines for power supply:

- keep power supply cables as short as possible
- use large diameters for power supply cables
- add 2200 $\mu$ F or larger filter capacitors near the motor driver unit especially if the distance to the power supply is large (i.e. more than 2-3m)

Note: there is no protection against reverse polarity integrated on the board.

### 3.2.1.2 RS485

For remote control and communication with a host system the PD-1161 provides a two wire RS485 bus interface. For proper operation the following items should be taken into account when setting up an RS485 network:

#### 1. BUS STRUCTURE:

The network topology should follow a bus structure as closely as possible. That is, the connection between each node and the bus itself should be as short as possible. Basically, it should be short compared to the length of the bus.

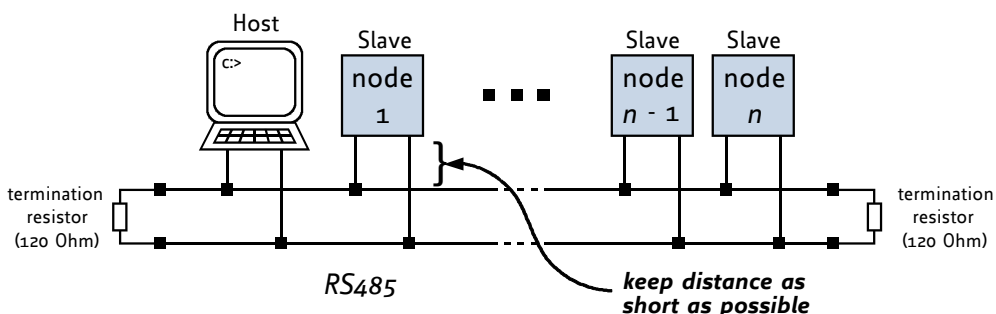

**Figure 3.5: RS485 bus structure**



2. **BUS TERMINATION:**

Especially for longer busses and/or multiple nodes connected to the bus and/or high communication speeds, the bus should be properly terminated at both ends. The PD-1161 does not integrate any termination resistor. Therefore, 120 Ohm termination resistors at both ends of the bus have to be added externally.

3. **NUMBER OF NODES:**

The RS-485 electrical interface standard (EIA-485) allows up to 32 nodes to be connected to a single bus. The bus transceiver used on the PD-1161 units (SN65HVD3082ED) has just 1/8th of the standard bus load and allows a maximum of 256 units to be connected to a single RS485 bus.

4. **NO FLOATING BUS LINES:**

Avoid floating bus lines while neither the host/master nor one of the slaves along the bus line is transmitting data (all bus nodes switched to receive mode). Floating bus lines may lead to communication errors. In order to ensure valid signals on the bus it is recommended to use a resistor network connecting both bus lines as well defined logic levels. In contrast to the termination resistors this network is normally required just once per bus. Certain RS485 interface converters available for PCs already include these additional resistors (e.g. USB-2-485).

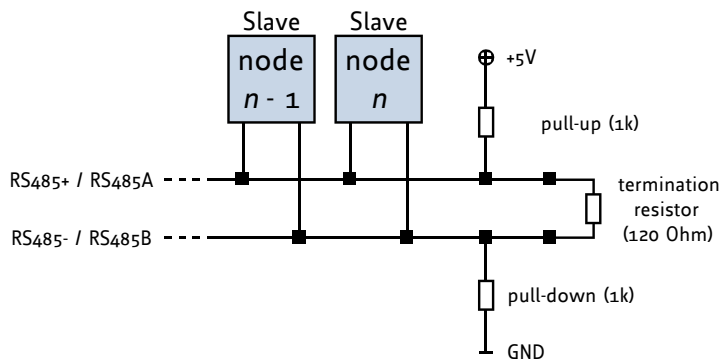

Figure 3.6: RS485 bus lines with resistor network

## 3.2.2 USB Connector

Pin	Label	Description
1	VBUS	+5V power
2	D-	Data -
3	D+	Data +
4	ID	not connected
5	GND	ground

Table 3.2 Mini USB connector

### 3.2.3 In/Out Connector

Pin	Label	Description
1	GND	Module ground (system and signal ground)
2	VCC	10... 30V DC power supply / nom. 24V DC
3	OUT_0	General purpose output, open collector
4	OUT_1	General purpose output, open collector
5	AIN_0	Analog input, 0... 10V (analog to digital converter range)
6	STOP_L/ STEP/ IN_1	Digital input, +24V compatible, programmable internal pull-up.* Functionality can be selected in software: a) Left stop switch input (connected to REF1 input of TMC429 motion controller) b) Step signal (connected to step input of TMC262 stepper driver) c) General purpose input (connected to processor)
7	STOP_R/ DIR/ IN_2	Digital input +24V compatible, programmable internal pull-up.* Functionality can be selected in software: a) Right stop switch input (connected to REF3 input of TMC429 motion controller) b) Direction signal (connected to direction input of TMC262 stepper driver) c) General purpose input (connected to processor)
8	HOME/ ENABLE/ IN_3	Digital input +24V compatible, programmable internal pull-up.* Functionality can be chosen in software: a) Home switch input (connected to processor) b) Enable signal (connected to processor) c) General purpose input (connected to processor)

**Table 3.3 In/Out connector**

\* It is possible to enable / disable pull-ups (1k to 5+V) in software for all three digital inputs. Pull-ups are always enabled / disabled for all three together / at the same time.

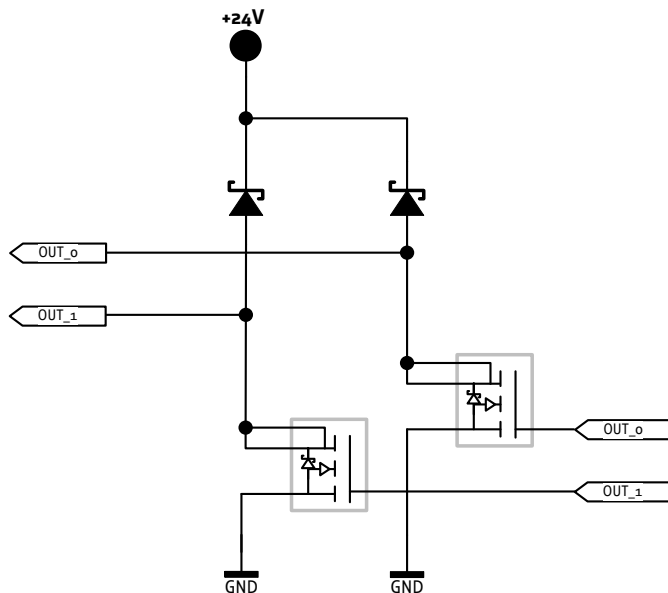

**Figure 3.3 Internal circuit of OUT\_0/1**

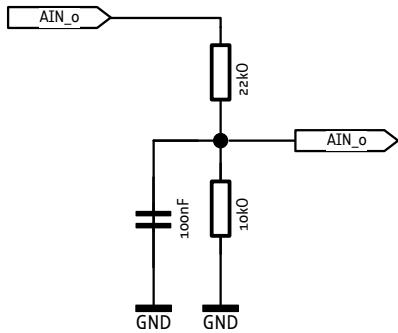

Figure 3.4 Internal circuit of AIN\_0

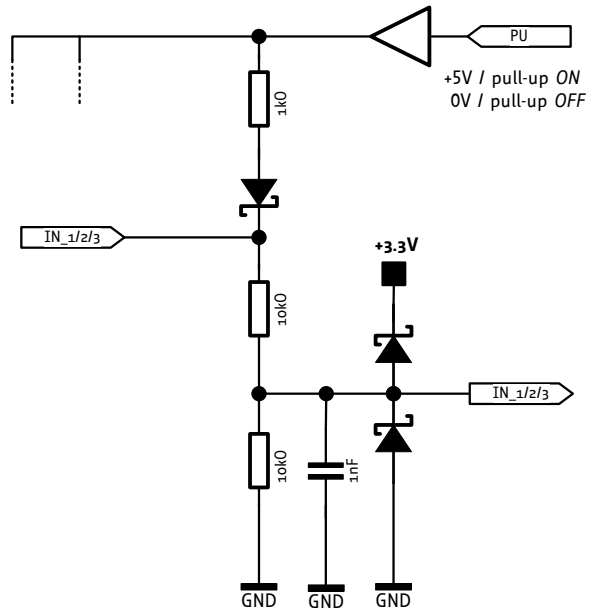

Figure 3.5 Internal circuit of IN\_1/2/3

### 3.2.3.1 Left and Right Limit Switches

The TMCM-1161 can be configured so that a motor has a left and a right limit switch. The motor stops when the traveler has reached one of the limit switches. An additional home switch might be used for initialization.

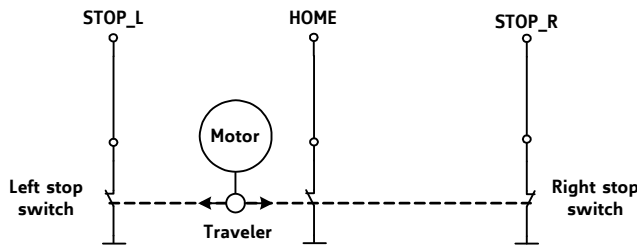

Figure 3.6 Limit switches and home switch

### 3.2.4 Motor Connector

Pin	Label	Description
1	OA1	Motor coil A
2	OA2	Motor coil A
3	OB1	Motor coil B
4	OB2	Motor coil B

Table 3.4 Motor connector

## 4 Reset to Factory Defaults

It is possible to reset the TMC1161 to factory default settings without establishing a communication link. This might be helpful in case communication parameters of the preferred interface have been set to unknown values or got accidentally lost.

For this procedure two pads on the bottom side of the board have to be shorted (see figure 4.12).

Please perform the following steps:

1. Power supply off and USB cable disconnected
2. Short two pads as marked in Figure 4.1
3. Power up board (power via USB is sufficient for this purpose)
4. Wait until the on-board red and green LEDs start flashing fast (this might take a while)
5. Power-off board (disconnect USB cable)
6. Remove short between pads
7. After switching on power-supply / connecting USB cable all permanent settings have been restored to factory defaults

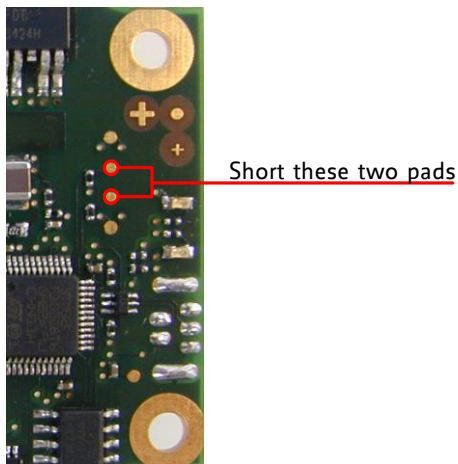

**Figure 4.1 Reset to factory default settings**

## 5 On-board LEDs

The board offers two LEDs in order to indicate board status. The function of both LEDs is dependent on the firmware version. With standard TMCL firmware the green LED should be slowly flashing during operation and the red LED should be off.

When there is no valid firmware programmed into the board or during firmware update the red and green LEDs are permanently on.

### BEHAVIOR OF LEDs WITH STANDARD TMCL FIRMWARE

Status	Label	Description
Heartbeat	Run	This green LED flashes slowly during operation.
Error	Error	This red LED lights up if an error occurs.

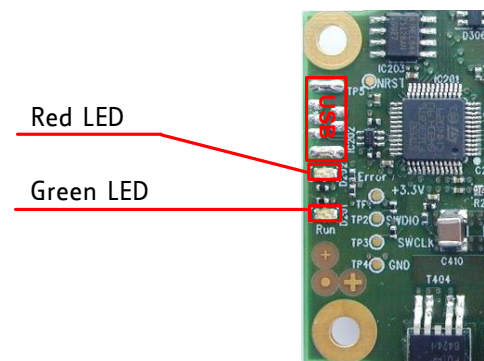

Figure 5.1 on-board LEDs

## 6 Operational Ratings

The operational ratings shown below should be used as design values. In no case should the maximum values be exceeded during operation.

Symbol	Parameter	Min	Typ	Max	Unit
V <sub>CC</sub>	Power supply voltage for operation	10	24	30	V DC
V <sub>USB</sub>	Power supply via USB connector		5		V
I <sub>USB</sub>	Current withdrawn from USB supply when USB bus powered (no other supply connected)		40		mA
I <sub>COIL_peak</sub>	Motor coil current for sine wave <b>peak</b> (chopper regulated, adjustable via software)	0		4	A
I <sub>COIL_RMS</sub>	Continuous motor current ( <b>RMS</b> )	0		2.8	A
I <sub>SUPPLY</sub>	Power supply current		<< I <sub>COIL</sub>	1.4 * I <sub>COIL</sub>	A
T <sub>ENV</sub>	Environment temperature at rated current (no forced cooling required)	-35 <sup>*)</sup>		+50	°C

**Table 6.1 General operational ratings of the module**

<sup>\*)</sup> limited by test equipment. Includes power-up / cold start at this temperature. It can be expected that the module will work down to -40°C.

Symbol	Parameter	Min	Typ	Max	Unit
V <sub>STOP_L/R_HOME</sub>	Input voltage for stop / home switch inputs STOP_L / STOP_R and HOME (also valid when configured for alternate function)	0		28	V
V <sub>STOP_L/R_HOME_L</sub>	Low level voltage for stop / home switch inputs STOP_L / STOP_R and HOME (also valid when configured for alternate function)	0		1.1	V
V <sub>STOP_L/R_HOME_H</sub>	High level voltage for stop / home switch inputs STOP_L / STOP_R and HOME (also valid when configured for alternate function)	2.9		28	V
V <sub>OUT_0/1</sub>	Voltage at open collector output OUT_0 / OUT_1	0		V <sub>CC</sub>	V
I <sub>OUT_0/1</sub>	Output sink current for OUT_0 / OUT_1			100	mA
V <sub>AIN_0</sub>	Full scale input voltage range for analog input AIN_0	0		10	V

**Table 6.2 Operational ratings of general purpose I/Os**

Symbol	Parameter	Min	Typ	Max	Unit
N <sub>RS485</sub>	Number of nodes connected to single RS485 network			256	

**Table 6.4 Operational ratings of the RS485 interface**

## 7 Functional Description

The TMCM-1161 is a highly integrated controller/driver module which can be controlled via several serial interfaces. Communication traffic is kept low since all time critical operations (e.g. ramp calculations) are performed on board. The nominal supply voltage of the unit is 24V DC. The module is designed for both, standalone operation and direct mode. Full remote control of device with feedback is possible. The firmware of the module can be updated via any of the serial interfaces.

In Figure 7.1 the main parts of the TMCM-1161 are shown.

- the microprocessor, which runs the TMCL operating system (connected to TMCL memory),
- the motion controller, which calculates ramps and speed profiles internally by hardware,
- the power driver with its energy efficient coolStep feature,
- the MOSFET driver stage, and
- the sensOstep encoder with resolutions of 10bit (1024 steps) per revolution.

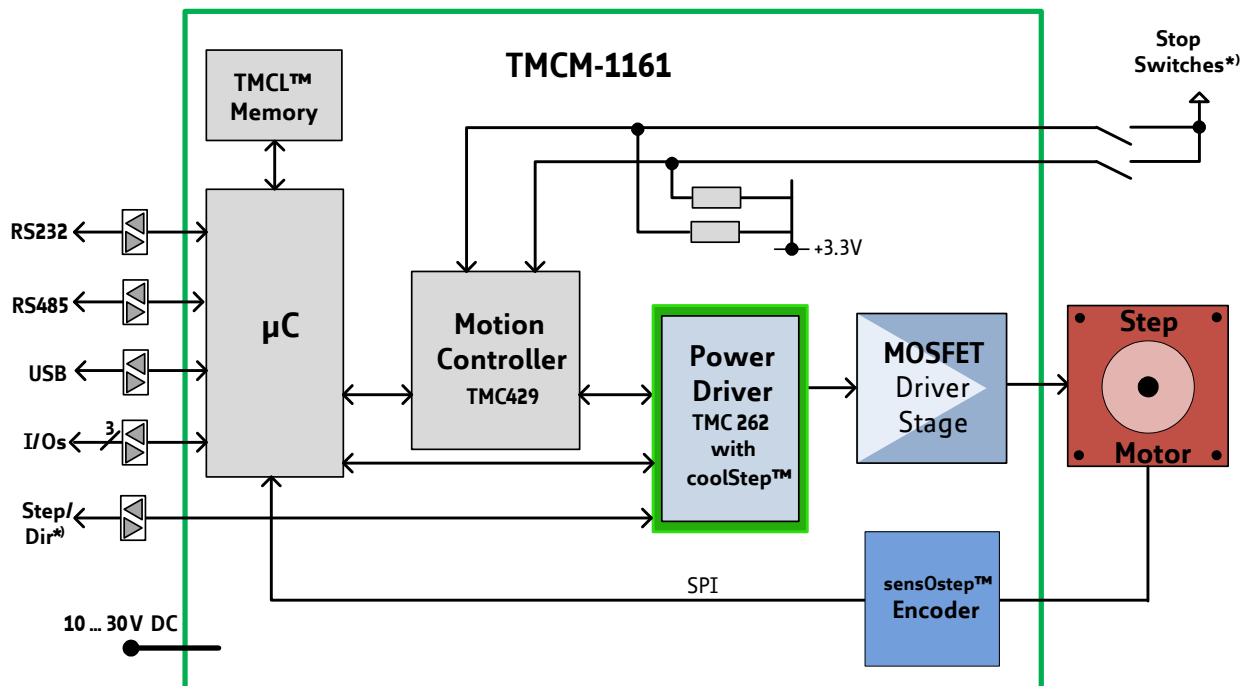

\*) The module offers three additional inputs. Functionality can be chosen by software:

- a) STOP\_L / STOP\_R / HOME
- b) STEP/DIR interface
- c) 3 general purpose inputs

**Figure 7.1 Main parts of the TMCM-1161**

The PC based software development environment TMCL-IDE for the Trinamic Motion Control Language (TMCM) can be downloaded free of charge from the TRINAMIC website ([www.trinamic.com](http://www.trinamic.com)). Using predefined TMCL high level commands like *move to position* a rapid and fast development of motion control applications is guaranteed. Please refer to the TMCM-1161 Firmware Manual for more information about TMCL commands.

## 8 TCM-1161 Operational Description

### 8.1 Calculation: Velocity and Acceleration vs. Microstep and Fullstep Frequency

The values of the parameters sent to the TMC429 do not have typical motor values like rotations per second as velocity. But these values can be calculated from the TMC429 parameters as shown in this section.

#### PARAMETERS OF TMC429

Signal	Description	Range
$f_{\text{CLK}}$	clock-frequency	16 MHz
velocity	-	0... 2047
a_max	maximum acceleration	0... 2047
pulse_div	divider for the velocity. The higher the value is, the less is the maximum velocity default value = 0	0... 13
ramp_div	divider for the acceleration. The higher the value is, the less is the maximum acceleration default value = 0	0... 13
Usrs	microstep-resolution (microsteps per fullstep = $2^{\text{Usrs}}$ )	0... 8 (a value of 7 or 8 is internally mapped to 6 by the TMC429)

**Table 8.1 TMC429 velocity parameters**

The *microstep-frequency* of the stepper motor is calculated with

$$\text{usf [Hz]} = \frac{f_{\text{CLK}} [\text{Hz}] \cdot \text{velocity}}{2^{\text{pulse\_div}} \cdot 2048 \cdot 32} \quad \text{with usf: microstep-frequency}$$

To calculate the *fullstep-frequency* from the microstep-frequency, the microstep-frequency must be divided by the number of microsteps per fullstep.

$$\text{fsf [Hz]} = \frac{\text{usf [Hz]}}{2^{\text{Usrs}}} \quad \text{with fsf: fullstep-frequency}$$

The change in the pulse rate per time unit (pulse frequency change per second – the *acceleration a*) is given by

$$a = \frac{f_{\text{CLK}}^2 \cdot a_{\text{max}}}{2^{\text{pulse\_div} + \text{ramp\_div} + 29}}$$

This results in acceleration in fullsteps of:

$$\text{af} = \frac{a}{2^{\text{Usrs}}} \quad \text{with af: acceleration in fullsteps}$$



Example:

Signal	value
f <sub>CLK</sub>	16 MHz
velocity	1000
a <sub>max</sub>	1000
pulse_div	1
ramp_div	1
usrs	6

$$msf = \frac{16\text{MHz} \cdot 1000}{2^1 \cdot 2048 \cdot 32} = \underline{\underline{12207031\text{Hz}}}$$

$$fsf[\text{Hz}] = \frac{12207031}{2^6} = \underline{\underline{1907.34\text{Hz}}}$$

$$a = \frac{(16\text{MHz})^2 \cdot 1000}{2^{1+1+29}} = \underline{\underline{119.21 \frac{\text{MHz}}{\text{s}}}}$$

$$af = \frac{119.21 \frac{\text{MHz}}{\text{s}}}{2^6} = \underline{\underline{1.863 \frac{\text{MHz}}{\text{s}}}}$$

Calculation of the number of rotations:

A stepper motor has e.g. 72 fullsteps per rotation.

$$\text{RPS} = \frac{fsf}{\text{fullstepsperrotation}} = \frac{1907.34}{72} = 26.49$$

$$\text{RPM} = \frac{fsf \cdot 60}{\text{fullstepsperrotation}} = \frac{1907.34 \cdot 60}{72} = 1589.46$$

## 9 Life Support Policy

TRINAMIC Motion Control GmbH & Co. KG does not authorize or warrant any of its products for use in life support systems, without the specific written consent of TRINAMIC Motion Control GmbH & Co. KG.

Life support systems are equipment intended to support or sustain life, and whose failure to perform, when properly used in accordance with instructions provided, can be reasonably expected to result in personal injury or death.

© TRINAMIC Motion Control GmbH & Co. KG 2012

Information given in this data sheet is believed to be accurate and reliable. However neither responsibility is assumed for the consequences of its use nor for any infringement of patents or other rights of third parties, which may result from its use.

Specifications are subject to change without notice.



## 10 Revision History

### 10.1 Document Revision

Version	Date	Author GE - Göran Eggers SD - Sonja Dwersteg	Description
1.00	2011-JUN-30	SD	Initial version
1.10	2011-AUG-22	GE	Updates for hardware version TMC262-1161_V10
1.11	2012-MAR-09	SD	<ul style="list-style-type: none"> <li>- Chapter 5 added</li> <li>- Chapter 4 added</li> <li>- Design updated</li> </ul>

Table 10.1 Document revision

### 10.2 Hardware Revision

Version	Date	Description
TMC262-1061_V10	2011-APR-20	First prototype version
TMC262-1161_V10	2011-JUL-22	Redesign: <ul style="list-style-type: none"> <li>- Corrected and modified clock concept</li> <li>- Stop switches connected to REF1+3 of TMC429</li> <li>- New encoder IC with 10bit resolution (max.)</li> </ul>

Table 10.2 Hardware revision

## 11 References

[TMC262-1161]	TMC262-1161 TMCL Firmware Manual
[TMC262]	TMC262 Datasheet
[TMC429]	TMC429 Datasheet
[TMCL-IDE]	TMCL-IDE User Manual
[QSH5718]	QSH5718 Manual
[QSH6018]	QSH6018 Manual

Please refer to [www.trinamic.com](http://www.trinamic.com).