

Hardware Version V1.2

HARDWARE MANUAL

+



+

+

TMCM-1021

Stepper Motor with
Controller / Driver
0.7A RMS / 24V DC
RS485 Interface

+

UNIQUE FEATURES:



coolStep™

stallGuard²

TRINAMIC Motion Control GmbH & Co. KG
Hamburg, Germany

www.trinamic.com



TRINAMIC
MOTION CONTROL

Table of Contents

1	Features.....	3
2	Order Codes	5
3	Mechanical and Electrical Interfacing.....	6
3.1	Size of Board	6
3.2	Connectors.....	7
3.2.1	Power, Communication and I/O Connector	8
3.2.2	Motor Connector.....	8
3.3	Power Supply	9
3.4	Communication.....	9
3.4.1	RS485	9
3.5	Inputs and Outputs	10
3.5.1	Multi-purpose Inputs.....	10
3.5.2	General Purpose Outputs.....	11
4	Reset to Factory Defaults.....	12
5	On-board LED.....	12
6	Operational Ratings	13
7	Functional Description.....	14
8	Life Support Policy.....	15
9	Revision History.....	16
9.1	Document Revision	16
9.2	Hardware Revision	16
10	References	16

1 Features

The TMC1021 is a single axis controller/driver module for 2-phase bipolar stepper motors with state of the art feature set. It is highly integrated, offers a convenient handling and can be used in many decentralized applications. The module can be mounted on the back of NEMA11 (28mm flange size) and has been designed for coil currents up to 0.7A RMS and 24V DC supply voltage. With its high energy efficiency from TRINAMIC's coolStep™ technology cost for power consumption is kept down. The TMCL™ firmware allows for both, standalone operation and direct mode.

MAIN CHARACTERISTICS

Highlights

- Motion profile calculation in real-time
- On the fly alteration of motor parameters (e.g. position, velocity, acceleration)
- High performance microcontroller for overall system control and serial communication protocol handling
- For position movement applications, where larger motors do not fit and higher torques are not required

Bipolar stepper motor driver

- Up to 256 microsteps per full step
- High-efficient operation, low power dissipation
- Dynamic current control
- Integrated protection
- stallGuard2 feature for stall detection
- coolStep feature for reduced power consumption and heat dissipation

Encoder

- sensOstep magnetic encoder (max. 1024 increments per rotation) e.g. for step-loss detection under all operating conditions and positioning supervision

Interfaces

- Up to 4 multi-purpose inputs (2 shared with outputs)
- 2 general purpose outputs
- RS485 2-wire communication interface

Software

- TMCL: standalone operation or remote controlled operation, program memory (non volatile) for up to 876 TMCL commands, and PC-based application development software TMCL-IDE available for free.

Electrical and mechanical data

- Supply voltage: +24V DC nominal (9... 28V DC)
- Motor current: up to 0.7A RMS (programmable)

Refer to separate TMCL Firmware Manual, too.

TRINAMICS UNIQUE FEATURES – EASY TO USE WITH TMCL

stallGuard2™ stallGuard2 is a high-precision sensorless load measurement using the back EMF on the coils. It can be used for stall detection as well as other uses at loads below those which stall the motor. The stallGuard2 measurement value changes linearly over a wide range of load, velocity, and current settings. At maximum motor load, the value goes to zero or near to zero. This is the most energy-efficient point of operation for the motor.

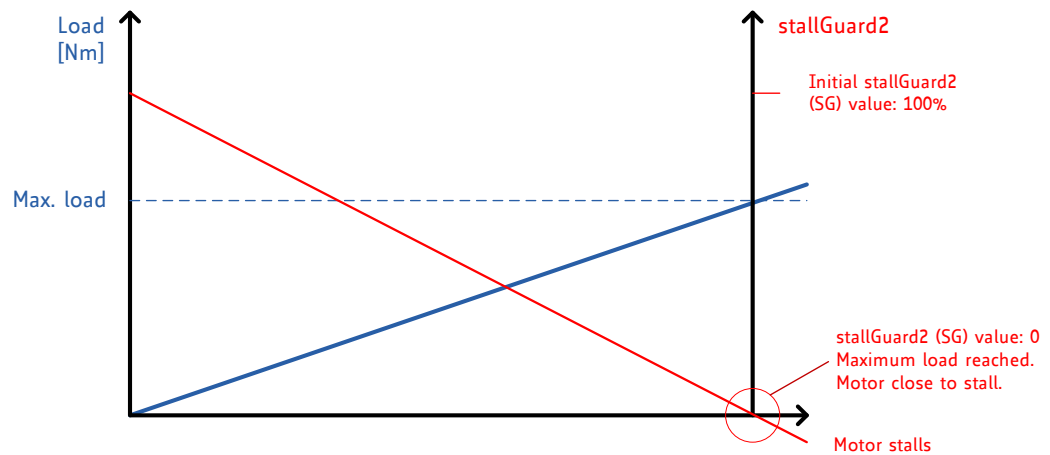

Figure 1.1 stallGuard2 load measurement SG as a function of load

coolStep™ coolStep is a load-adaptive automatic current scaling based on the load measurement via stallGuard2 adapting the required current to the load. Energy consumption can be reduced by as much as 75%. coolStep allows substantial energy savings, especially for motors which see varying loads or operate at a high duty cycle. Because a stepper motor application needs to work with a torque reserve of 30% to 50%, even a constant-load application allows significant energy savings because coolStep automatically enables torque reserve when required. Reducing power consumption keeps the system cooler, increases motor life, and allows reducing cost.

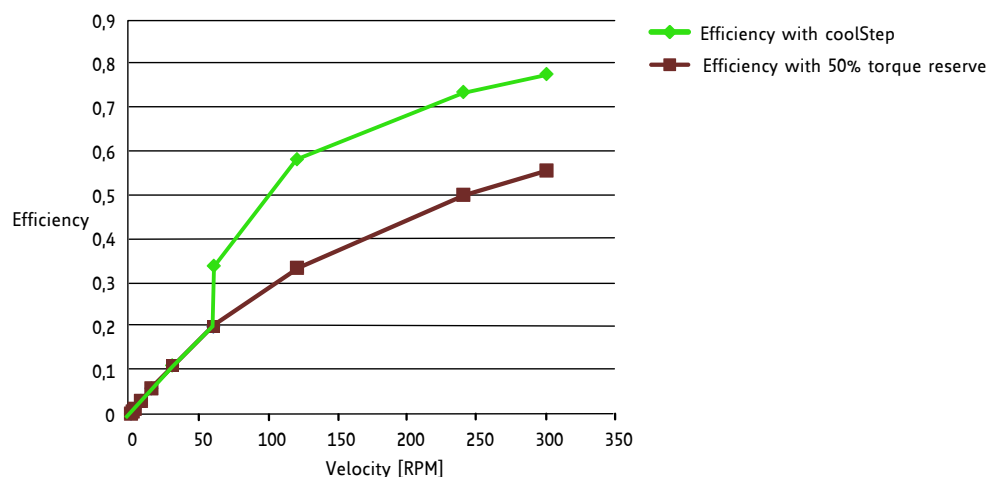

Figure 1.2 Energy efficiency example with coolStep

2 Order Codes

Order code	Description	Size of unit
TMCM-1021	Single axis bipolar stepper motor controller/driver electronics with integrated encoder electronics	28mm x 28mm

Table 2.2: Order codes

A cable loom set is available for this module:

Order code	Description
TMCM-1021-CABLE	Cable loom for TMCM-1021 <ul style="list-style-type: none">- 1x cable loom for power, communication and I/O connector (cable length approx. 200mm)- 1x cable loom for motor connector (cable length ca. 200mm)

Table 2.5: Cable loom order code

3 Mechanical and Electrical Interfacing

3.1 Size of Board

The board with the controller/driver electronics has an overall size of 28mm x 28mm in order to fit on the back side of a NEMA11 (28mm flange size) stepper motor. The printed circuit board outline is marked green in the following figure:

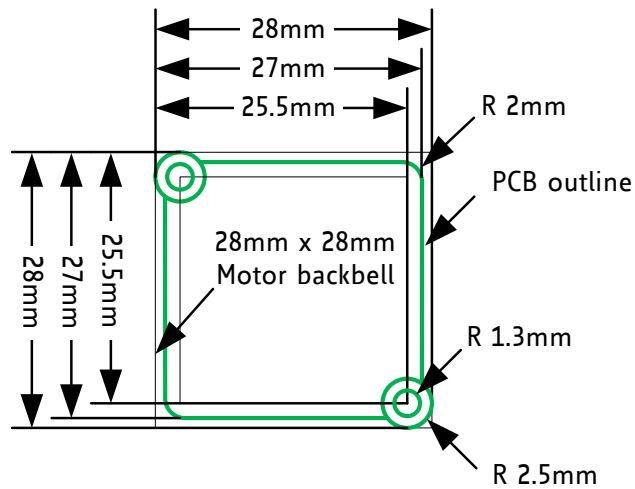

Figure 3.1: Board dimensions and position of mounting holes

3.2 Connectors

The TMC1021 has two connectors, an 8-pin power and input/output connector and a 4-pin motor connector (used to connect the attached motor).

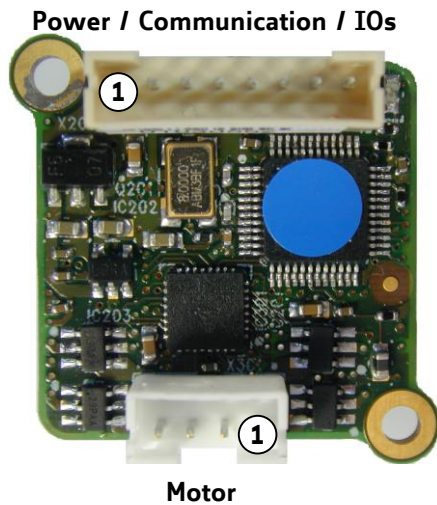

Figure 3.2: TMC1021 connectors

Overview of connector and mating connector types:

Label	Connector type	Mating connector type
Power, communication and I/O	JST B8B-PH-K-S (JST PH series, 8pins, 2mm pitch)	Connector housing: JST PHR-8 Contacts: JST SPH-002T-P0.5S Wire: 0.22mm ² , AWG 24
Motor	JST B4B-PH-K-S (JST PH series, 4pins, 2mm pitch)	Connector housing: JST PHR-4 Contacts: JST SPH-002T-P0.5S Wire: 0.22mm ² , AWG 24

Table 3.2: Connectors and mating connectors, contacts and applicable wire

3.2.1 Power, Communication and I/O Connector

An 8-pin JST PH-series 2mm pitch single row connector is used for power supply, RS485 serial communication and additional multi-purpose inputs and outputs.

Pin	Label	Direction	Description
1	GND	Power (GND)	GND
2	VDD	Power (Supply)	VDD (+9V...+28V)
3	RS485+	Bidirectional	RS485 interface, diff. signal (non-inverting)
4	RS485-	Bidirectional	RS485 interface, diff. signal (inverting)
5	IN_0	Input	Digital input (+24V compatible)
			Alternate function 1: step input
			Alternate function 2: left stop switch
6	IN_1	Input	Digital input (+24V compatible)
			Alternate function 1: direction input
			Alternate function 2: right stop switch
7	OUT_0 / IN_2	Output / Input	Open drain output with freewheeling diode (max. 100mA)
			Alternate function 1: digital input (+24V compatible)
			Alternate function 2: home switch
8	OUT_1 / IN_3	Output / Input	Open drain output with freewheeling diode (max. 100mA)
			Alternate function 1: digital input (+24V compatible)
			Alternate function 2: analog input

Table 3.3: Power, communication and I/O connector

3.2.2 Motor Connector

The motor connector is used for connecting the four motor wires to the electronics.

Pin	Label	Direction	Description
1	OB2	Output	Pin 2 of motor coil B
2	OB1	Output	Pin 1 of motor coil B
3	OA2	Output	Pin 2 of motor coil A
4	OA1	Output	Pin 1 of motor coil A

Table 3.4: Motor connector

Example for connecting a motor.

TMC1021		QSH2818 Motor	
Motor connector pin	Cable colour	Coil	Description
1	Blue	B-	Motor coil B pin 2
2	Red	B	Motor coil B pin 1
3	Green	A-	Motor coil A pin 2
4	Black	A	Motor coil A pin 1

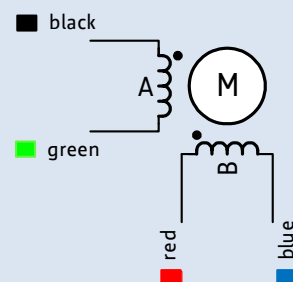

3.3 Power Supply

For proper operation care has to be taken with regard to power supply concept and design. Due to space restrictions the TCM-1021 includes just about 20 μ F/35V of supply filter capacitors. These are ceramic capacitors which have been selected for high reliability and long life time. The module includes a 28V suppressor diode for over-voltage protection. There is no reverse polarity protection. The module will short any reversed supply voltage due to internal diodes of the driver transistors.

It is absolutely necessary that the power supply voltage is kept below the upper limit of 28V under all circumstances (please see also chapter 6, operating values). Otherwise the driver electronics might be seriously damaged! Especially, when the selected operating voltage is near the upper limit a regulated power supply is highly recommended.

It is recommended to connect an electrolytic capacitor of significant size (e.g. 470 μ F/35V) to the power supply lines next to the TCM-1021!

Rule of thumb for size of electrolytic capacitor: $c = 1000 \frac{\mu F}{A} \times I_{MOT}$

In addition to power stabilization (buffer) and filtering this added capacitor will also reduce any voltage spikes which might otherwise occur from a combination of high inductance power supply wires and the ceramic capacitors. In addition it will limit slew-rate of power supply voltage at the module. The low ESR of ceramic-only filter capacitors may cause stability problems with some switching power supplies.

3.4 Communication

3.4.1 RS485

For remote control and communication with a host system the TCM-1021 provides a two wire RS485 bus interface. For proper operation the following items should be taken into account when setting up an RS485 network:

1. **BUS STRUCTURE:**

The network topology should follow a bus structure as closely as possible. That is, the connection between each node and the bus itself should be as short as possible. Basically, it should be short compared to the length of the bus.

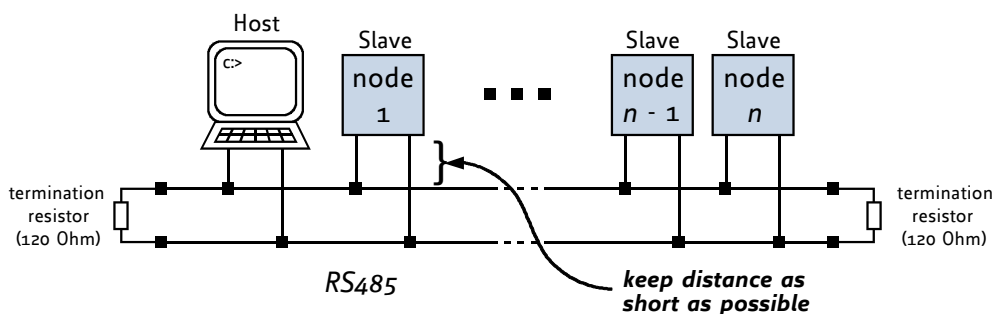

Figure 3.5: Bus structure

2. **BUS TERMINATION:**

Especially for longer busses and/or multiple nodes connected to the bus and/or high communication speeds, the bus should be properly terminated at both ends. The TCM-1021 does not integrate any termination resistor. Therefore, 120 Ohm termination resistors at both ends of the bus have to be added externally.

3. **NUMBER OF NODES:**

The RS485 electrical interface standard (EIA-485) allows up to 32 nodes to be connected to a single bus. The bus transceiver used on the TMCM-1021 units (SN65HVD3082ED) has just 1/8th of the standard bus load and allows a maximum of 256 units to be connected to a single RS485 bus.

4. **NO FLOATING BUS LINES:**

Avoid floating bus lines while neither the host/master nor one of the slaves along the bus line is transmitting data (all bus nodes switched to receive mode). Floating bus lines may lead to communication errors. In order to ensure valid signals on the bus it is recommended to use a resistor network connecting both bus lines to well defined logic levels. In contrast to the termination resistors this network is normally required just once per bus. Certain RS485 interface converters available for PCs already include these additional resistors (e.g. USB-2-485).

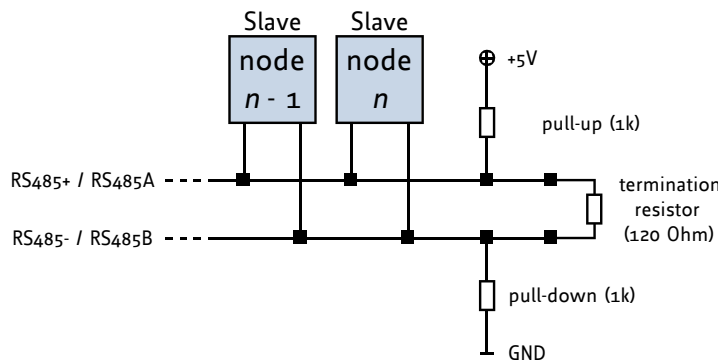

Figure 3.6: Bus lines with resistor network

3.5 Inputs and Outputs

3.5.1 Multi-purpose Inputs

The eight pin connector of the TMCM-1021 provides four general purpose inputs IN_0, IN_1, IN_2 and IN_3. The first two inputs have dedicated connector pins while the other two share pins with two general purpose outputs.

All four inputs are protected using voltage resistor dividers together with limiting diodes against voltages below 0V (GND) and above +3.3V DC (see figure below).

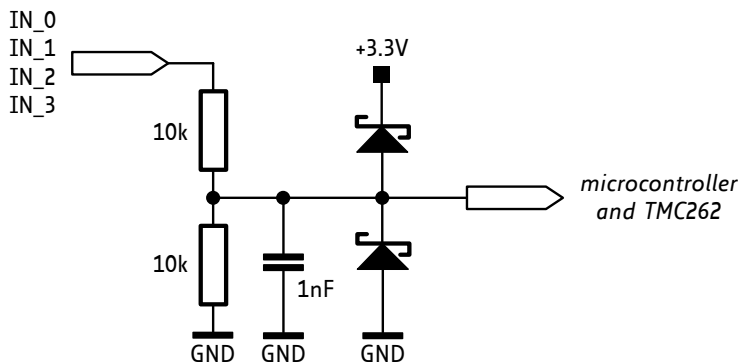

Figure 3.7: General purpose inputs

The four inputs have alternate functionality depending on configuration in software. The following functions are available:

Label (connector pin)	Default Function	Alternate function 1	Alternate function 2
IN_0 (5)	Digital input	Step signal input (connected to TMC262 step input)	Left stop switch
IN_1 (6)	Digital input	Direction signal input (connected to TMC262 direction input)	Right stop switch
OUT_0 / IN_2 (7)	Output	Digital input	Home switch
OUT_1 / IN_3 (8)	Output	Digital input	Analog input (0... +6.6V, 12bit resolution)

Table 3.5: Multi-purpose inputs / alternate functions

All four inputs are connected to the on-board processor and can be used as general purpose digital inputs.

Using the alternate functionality of IN_0 and IN_1 it is possible to control the on-board stepper motor driver with the help of an external stepper motor controller using step and direction signals. For the step and direction signals the signal levels are the same as for the general purpose digital inputs.

IN_3 can be used as analog input, also. A 12bit analog to digital converter integrated in the microcontroller will convert any analog input voltage between 0 and +6.6V to a digital value between 0 and 4095 then.

3.5.2 General Purpose Outputs

The eight pin connector of the TMC262 provides two general purpose outputs. These two outputs are open-drain outputs and can sink up to 100mA each. The outputs of the N-channel MOSFET transistors are connected to freewheeling diodes each for protection against voltage spikes especially from inductive loads (relais etc.).

Both outputs OUT_0 and OUT_1 share pins with two of the four inputs (IN_2 resp. IN_3).

Please take into account the 20k (2x 10k in series) resistance to ground (transistor not active) of the input voltage divider (figure 4.8) when designing the external "load" circuit.

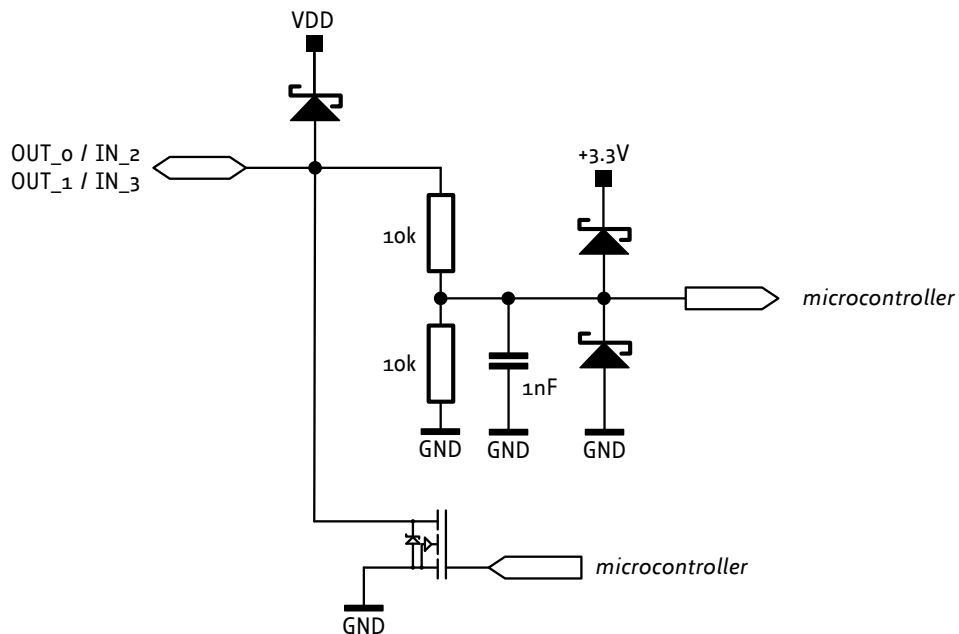

Figure 3.8: General purpose outputs

4 Reset to Factory Defaults

It is possible to reset the TMCM-1021 to factory default settings without establishing a communication link. This might be helpful in case communication parameters of the preferred interface have been set to unknown values or got accidentally lost.

For this procedure two pads on the bottom side of the board have to be shorted (see Figure 4.1).

Please perform the following steps:

1. Power supply off and USB cable disconnected
2. Short two pads as marked in Figure 4.1
3. Power up board (power via USB is sufficient for this purpose)
4. Wait until the on-board red and green LEDs start flashing fast (this might take a while)
5. Power-off board (disconnect USB cable)
6. Remove short between pads
7. After switching on power-supply / connecting USB cable all permanent settings have been restored to factory defaults

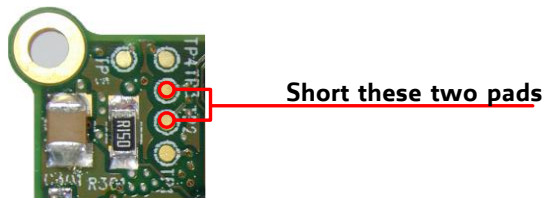
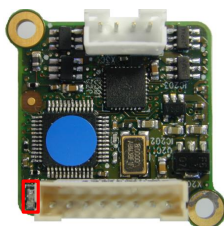

Figure 4.1 Reset to factory default settings

5 On-board LED

The board offers one LED in order to indicate board status. The function of the LED is dependent on the firmware version. With standard TMCL firmware the green LED flashes slowly during operation.

When there is no valid firmware programmed into the board or during firmware update the green LED is permanently on.



Green LED

Figure 5.1 On-board LED

6 Operational Ratings

The operational ratings show the intended or the characteristic ranges and should be used as design values.

In no case shall the maximum values be exceeded!

Symbol	Parameter	Min	Typ	Max	Unit
VDD	Power supply voltage for operation	9	12... 24	28	V
I _{COIL}	Motor coil current for sine wave peak (chopper regulated, adjustable via software)	0		1000*)	mA
I _{MC}	Continuous motor current (RMS)	0		700*)	mA
I _S	Power supply current		<< I _{COIL}	1.4 * I _{COIL}	A
T _{ENV}	Environment temperature at rated current (no forced cooling required)	-35	tbd	+60	°C

Table 6.1: General operational ratings of module

*) maximum setting for prototype and first versions of TMCL firmware. Will be adapted in firmware for series version.

Symbol	Parameter	Min	Typ	Max	Unit
V _{OUT_0/1}	Voltage at open collector output	0		+VDD	V
I _{OUT_0/1}	Output sink current			100	mA
V _{IN_digital_0/1/2/3}	Input voltage for IN_0, IN_1, IN_2, IN_3 when used as digital input	0		+VDD	V
V _{IN_digital_L_0/1/2/3}	Low level voltage for GPIO and GPI1 when used as digital input	0		1.2	V
V _{IN_digital_H_0/1/2/3}	High level voltage for GPIO and GPI1 when used as digital input	4		+VDD	V
V _{IN_analog_3}	Measurement range for IN_3 when used as analogue input	0		+6.6	V

Table 6.2: Operational ratings of multi-purpose I/Os

Symbol	Parameter	Min	Typ	Max	Unit
N _{RS485}	Number of nodes connected to single RS485 network			256	

Table 6.3: Operational ratings of RS485 interface

7 Functional Description

The TMCM-1021 is a highly integrated controller/driver module which can be controlled via RS485 interface. Communication traffic is kept low since all time critical operations (e.g. ramp calculations) are performed on board. The nominal supply voltage of the unit is 24V DC. The module is designed for both, standalone operation and direct mode. Full remote control of device with feedback is possible. The firmware of the module can be updated via the serial interface.

In Figure 7.1 the main parts of the module are shown:

- the microprocessor, which runs the TMCL operating system (connected to TMCL memory),
- the power driver with its energy efficient coolStep feature,
- the MOSFET driver stage, and
- the sensOstep encoder with resolutions of 10bit (1024 steps) per revolution.

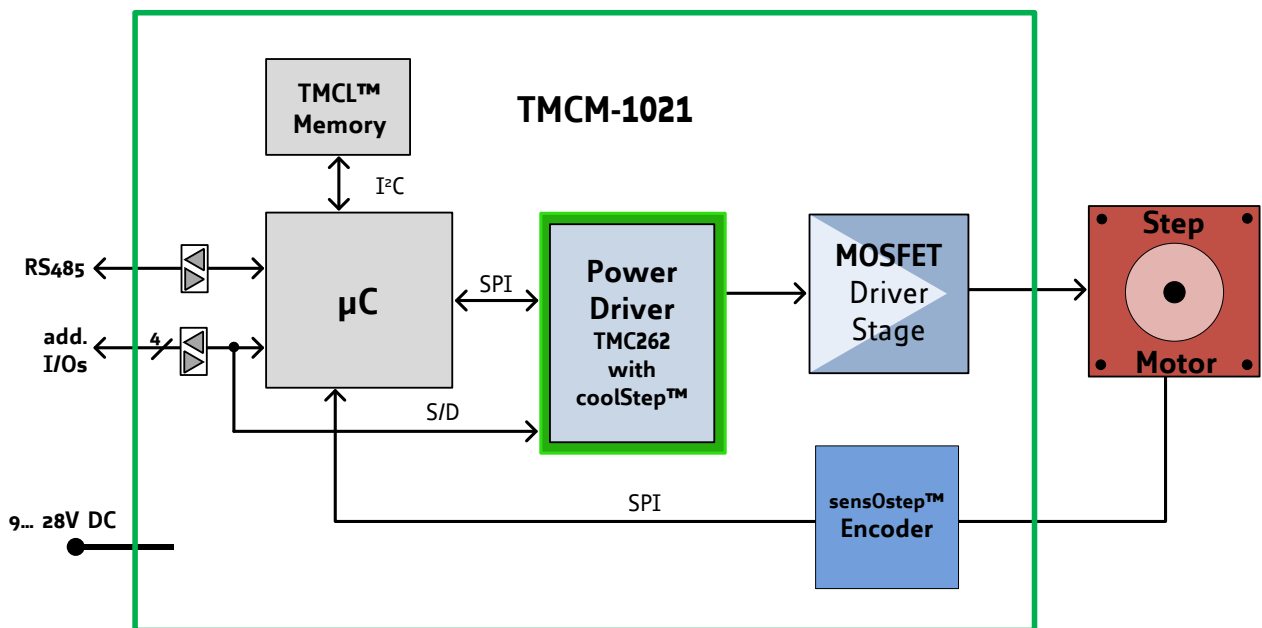

Figure 7.1: Main parts of TMCM-1021

The TMCM-1021 comes with the PC based software development environment TMCL-IDE for the Trinamic Motion Control Language (TMCL). Using predefined TMCL high level commands like *move to position* a rapid and fast development of motion control applications is guaranteed. Please refer to the TMCM-1021 Firmware Manual for more information about TMCL commands.

8 Life Support Policy

TRINAMIC Motion Control GmbH & Co. KG does not authorize or warrant any of its products for use in life support systems, without the specific written consent of TRINAMIC Motion Control GmbH & Co. KG.

Life support systems are equipment intended to support or sustain life, and whose failure to perform, when properly used in accordance with instructions provided, can be reasonably expected to result in personal injury or death.

© TRINAMIC Motion Control GmbH & Co. KG 2012

Information given in this data sheet is believed to be accurate and reliable. However neither responsibility is assumed for the consequences of its use nor for any infringement of patents or other rights of third parties, which may result from its use.

Specifications are subject to change without notice.



9 Revision History

9.1 Document Revision

Version	Date	Author GE – Göran Eggers SD – Sonja Dwersteg	Description
0.90	2011-AUG-02	GE	Initial version
0.91	2011-AUG-25	SD	Information about left, right, and home switch added. Minor changes
0.92	2011-NOV-10	GE	<ul style="list-style-type: none"> - Motor connector corrected and motor connection added - General purpose output circuit extended - Hardware revision list updated
1.00	2012-MAR-09	SD	<ul style="list-style-type: none"> - Rule of thumb for capacitor added. - Design updated - Chapter 5 (on-board LED) new - Chapter 4 (reset to factory defaults) new

Figure 9.1: Document revision

9.2 Hardware Revision

Version	Date	Description
TMC262_V10	2011-JUL-11	Initial version
TMC262_V11	2011-AUG-18	<ul style="list-style-type: none"> - TMC262 clock generation switched to internal clock - Encoder circuit corrected - LED added
TMC262_V12	2011-SEP-28	<ul style="list-style-type: none"> - LED moved to location near 8pin connector (version 1.2 is 100% firmware compatible with V1.1)

Figure 9.2: Hardware revision

10 References

[TMC262]	TMC262 TMC262 Firmware Manual
[QSH2818-32-07-006]	NEMA11 / 28mm bipolar stepper motor
[QSH2818-51-07-012]	NEMA11 / 28mm bipolar stepper motor
[JST]	JST PH connector (2.0mm pitch, disconnectable crimp style) http://www.jst.com
[USB-2-485]	USB-2-485 interface converter
[TMC262]	TMC262 datasheet

TRINAMIC manuals are available on <http://www.trinamic.com>.