



SI251

SinCos interpolator for encoders and measuring systems with SinCos output

Product features:

- Converts 1 Vpp standard sinus wave signals into incremental square wave signals
- Outputs A, /A, B, /B, Z, /Z (RS422 / TTL) and A, B, Z (18 ... 30 V HTL)
- Adjustable multiplier for interpolation rates from 1 : 5 ... 1 : 50
- Adjustable divider 1 : 1 ... 1 : 128 to reduce the output frequency
- Sinus-input frequency 0 ... 400 kHz
- Quadrature output frequency up to 4 MHz
- Adjustable glitch filter
- Power supply 18 ... 30 VDC

Version:	Description:
SI25101a/ AF/ Nov. 04	Original
SI25101b/ AF/HK/ Feb.05	Corrections with connectors male/female, DIL2 settings and miscellaneous small bugs
SI25101c_oi/Jun-15/ag	„Safety Instructions“ and „Technical Specifications“ new. „Legal notices“ supplemented and manual-design updated.

Legal notices:
All contents included in this manual are protected by the terms of use and copyrights of motrona GmbH. Any reproduction, modification, usage or publication in other electronic and printed media as well as in the internet requires prior written authorization by motrona GmbH.

Table of Contents

1. Safety Instructions and Responsibility	3
1.1. General Safety Instructions.....	3
1.2. Use according to the intended purpose	3
1.3. Installation.....	4
1.4. Cleaning, Maintenance and Service Notes.....	4
2. Introduction	5
3. Block Diagram.....	6
4. Connections	7
4.1. Connection overview	8
5. Pin assignment of SUB-D-connectors.....	9
5.1. Sin/Cos inputs	9
5.2. RS 422 impulse output	10
6. Switch settings	11
7. Frequency Divider and Error Signals.....	14
8. Delays.....	15
9. Miscellaneous Hints	15
10. Dimensions	16
11. Technical Specifications	17

1. Safety Instructions and Responsibility

1.1. General Safety Instructions

This operation manual is a significant component of the unit and includes important rules and hints about the installation, function and usage. Non-observance can result in damage and/or impairment of the functions to the unit or the machine or even in injury to persons using the equipment!

Please read the following instructions carefully before operating the device and observe all safety and warning instructions! Keep the manual for later use.

A pertinent qualification of the respective staff is a fundamental requirement in order to use these manual. The unit must be installed, connected and put into operation by a qualified electrician.

Liability exclusion: The manufacturer is not liable for personal injury and/or damage to property and for consequential damage, due to incorrect handling, installation and operation. Further claims, due to errors in the operation manual as well as misinterpretations are excluded from liability.

In addition the manufacturer reserve the right to modify the hardware, software or operation manual at any time and without prior notice. Therefore, there might be minor differences between the unit and the descriptions in operation manual.

The raiser respectively positioner is exclusively responsible for the safety of the system and equipment where the unit will be integrated.

During installation or maintenance all general and also all country- and application-specific safety rules and standards must be observed.

If the device is used in processes, where a failure or faulty operation could damage the system or injure persons, appropriate precautions to avoid such consequences must be taken.

1.2. Use according to the intended purpose

The unit is intended exclusively for use in industrial machines, constructions and systems. Non-conforming usage does not correspond to the provisions and lies within the sole responsibility of the user. The manufacturer is not liable for damages which has arisen through unsuitable and improper use.

Please note that device may only be installed in proper form and used in a technically perfect condition (in accordance to the Technical Specifications, see chapter [11](#)). The device is not suitable for operation in explosion-proof areas or areas which are excluded by the EN 61010-1 standard.

1.3. Installation

The device is only allowed to be installed and operated within the permissible temperature range. Please ensure an adequate ventilation and avoid all direct contact between the device and hot or aggressive gases and liquids.

Before installation or maintenance, the unit must be disconnected from all voltage-sources. Further it must be ensured that no danger can arise by touching the disconnected voltage-sources.

Devices which are supplied by AC-voltages, must be connected exclusively by switches, respectively circuit-breakers with the low voltage network. The switch or circuit-breaker must be placed as near as possible to the device and further indicated as separator.

Incoming as well as outgoing wires and wires for extra low voltages (ELV) must be separated from dangerous electrical cables (SELV circuits) by using a double resp. increased isolation.

All selected wires and isolations must be conform to the provided voltage- and temperature-ranges. Further all country- and application-specific standards, which are relevant for structure, form and quality of the wires, must be ensured. Indications about the permissible wire cross-sections for wiring are described in the Technical Specifications (see chapter [11](#)).

Before first start-up it must be ensured that all connections and wires are firmly seated and secured in the screw terminals. All (inclusively unused) terminals must be fastened by turning the relevant screws clockwise up to the stop.

Overvoltages at the connections must be limited to values in accordance to the overvoltage category II.

For placement, wiring, environmental conditions as well as shielding and earthing/grounding of the supply lines the general standards of industrial automation industry and the specific shielding instructions of the manufacturer are valid. Please find all respective hints and rules on www.motrona.com/download.html --> "[General EMC Rules for Wiring, Screening and Earthing]" .

1.4. Cleaning, Maintenance and Service Notes

To clean the front of the unit please use only a slightly damp (not wet!), soft cloth. For the rear no cleaning is necessary. For an unscheduled, individual cleaning of the rear the maintenance staff or assembler is self-responsible.

During normal operation no maintenance is necessary. In case of unexpected problems, failures or malfunctions the device must be shipped for back to the manufacturer for checking, adjustment and reparation (if necessary). Unauthorized opening and repairing can have negative effects or failures to the protection-measures of the unit.

2. Introduction

SI251 represents an encoder interface unit, designed to convert output signals of so-called "sine-cosine-encoders" and similar measuring systems into incremental quadrature impulse signals.

Under consideration of an adjustable multiplier the unit interpolates a corresponding number of impulses from every sine wave. An additional programmable divider provides division of the impulses if applicable, before they appear at the output. Impulses are available with TTL/RS422 standard (A, /A, B, /B, Z, /Z) and with HTL standard (A, B, Z, 18 ... 30 V) at the same time.

SI251 also possesses a selectable glitch filter to minimize interferences on the signal lines. The maximum sine input frequency is 400 kHz. The interpolation rate can be set in a range from 5 to 50, i.e. the unit can generate up to 50 pulses from one sine period.

The maximum output frequency is 4 MHz with use of the RS422 output, and approx. 100 kHz when the HTL output is used. Where applicable, the output frequency can be reduced by a selectable divider 1 : 1 ... 1 : 128.

Independent of the selected interpolation rate, an interpolation time can be set in order to limit the output frequency to a desired maximum value.

The unit provides auxiliary output voltages of 5.2 volts and approx. 20 volts, all short-circuit-proofed, for power supply of the sine/cosine encoder.

Errors will be indicated by a LED and at the same time by a digital control output. Errors can be reset by means of a pushbutton on the unit, or by a remote reset signal.

All settings are done by means of two DIL switches which are accessible from the top site and the bottom site of the housing.

The mechanical construction provides a compact housing for rail mounting, with 12 screw terminals and two SUB-D-connectors

3. Block Diagram

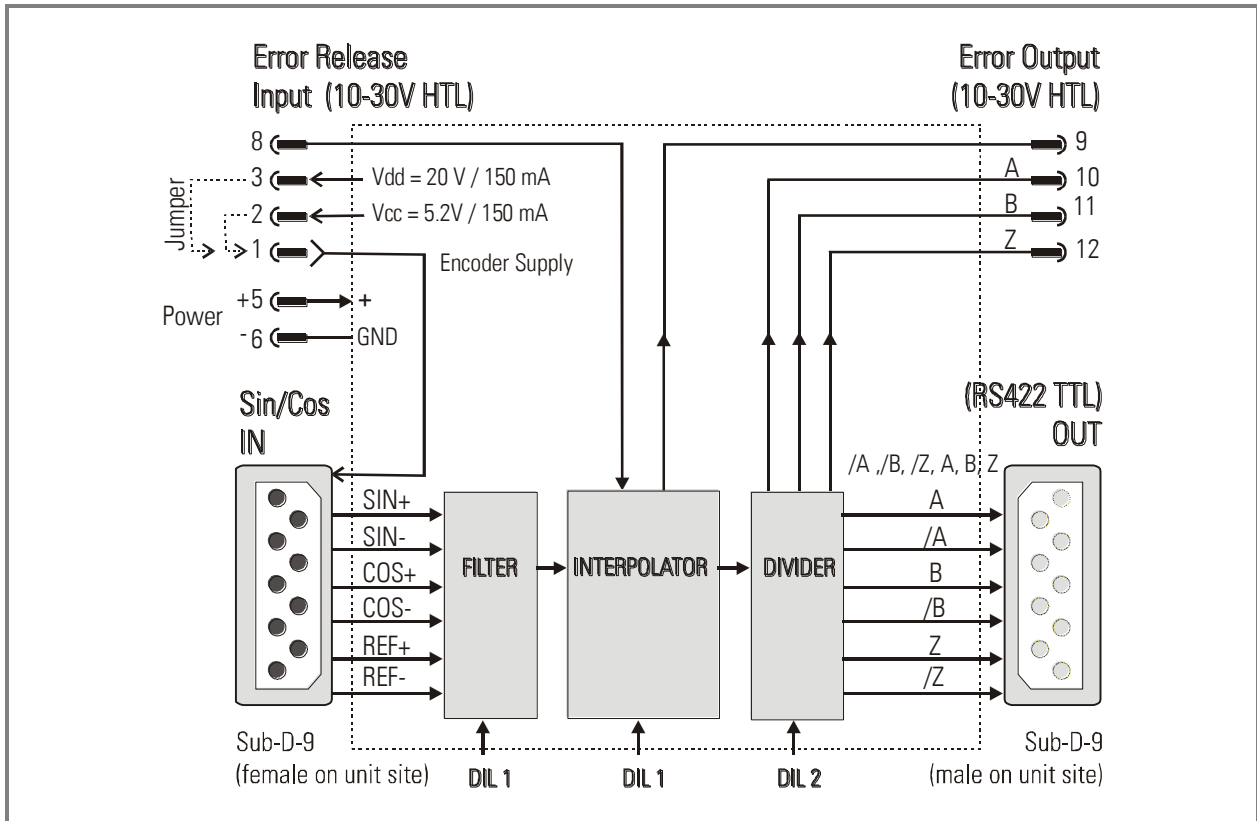

4. Connections

The unit provides a 9-pin SUB-D connector (female on the unit site) for connection of the SinCos sensor. For easy power supply of the encoder, an external jumper allows to switch an auxiliary voltage of either 5.2 V or approx. 20 V to the same connector. Also the mean voltage is available on the connector pins, allowing also the use of sensors with non-differential sinus output.

The incremental output impulses are available with RS422 standard and HTL standard (push-pull) at the same time, and one output of both or both outputs at a time may be used, quite according to the application.



All inputs and outputs as well as the power supply refer to the same reference potential (GND)!

In case of errors the Error Output switches to HIGH. At the same time the yellow front LED will be lit. To release an Error state, a HIGH signal must be applied to the "Error Release" input (PNP, HTL, a positive signal of 10 ... 30 VDC will release the error). Errors may be cleared also by pushing the small button on the top site of the unit.

The unit operates with a 18 ... 30 VDC power applied to terminals 5 (+) and 6 (-)

4.1. Connection overview

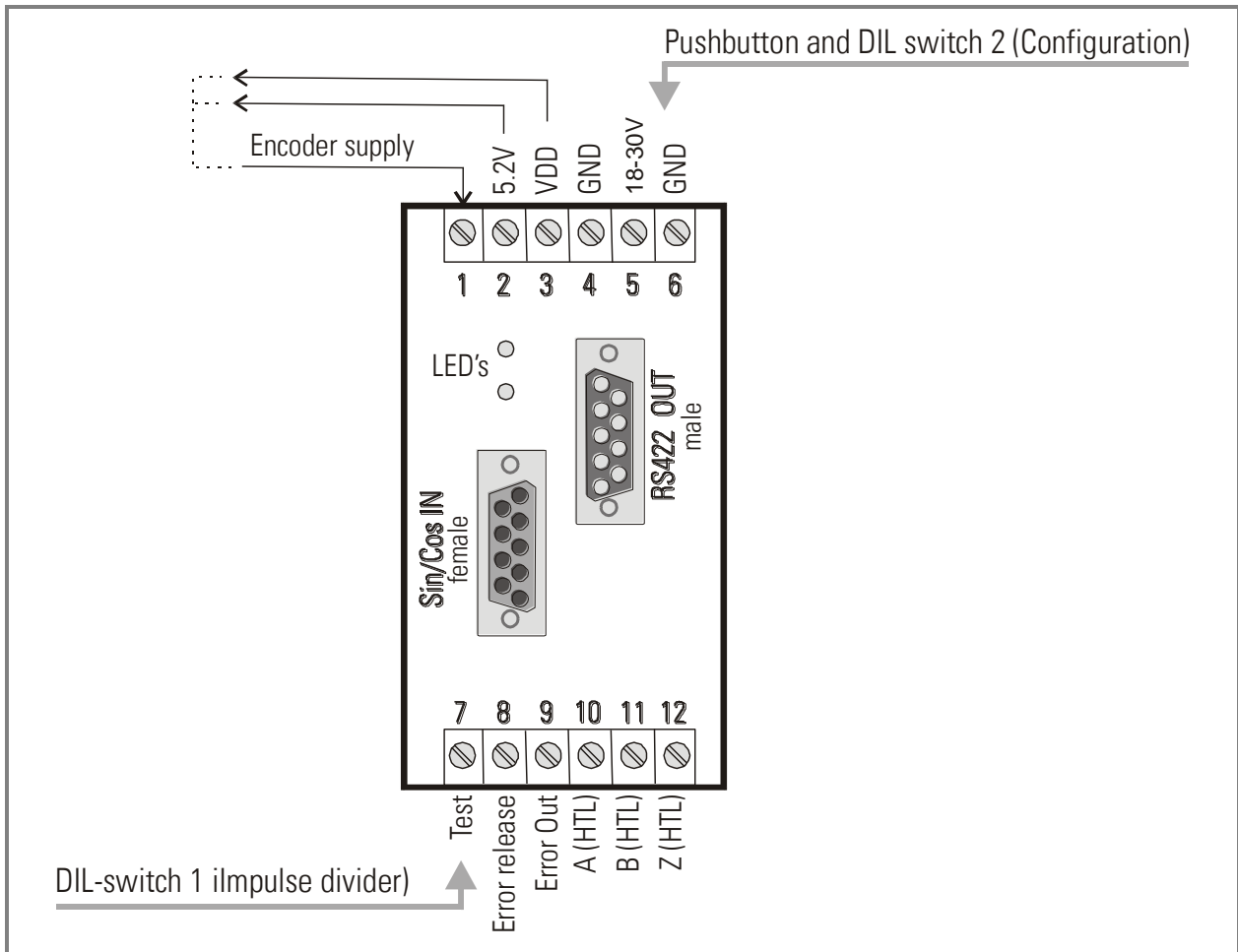

At any time, the over-all transmission characteristics of encoder, external components and capacity of cable must ensure proper signals at the input of the unit, with respect to levels, shape and phase displacement A/B.

The output swing of the **HTL push-pull outputs** corresponds to the input supply voltage on terminals 5 and 6.

5. Pin assignment of SUB-D-connectors

5.1. Sin/Cos inputs

Standard encoders with differential outputs can be connected directly to the corresponding pins **SIN+**, **SIN-**, **COS+**, **COS-**, **REF+**, **REF-**. Where longer cables must be used, terminating resistors between the non-inverted and the inverted signal of each channel may be of advantage.

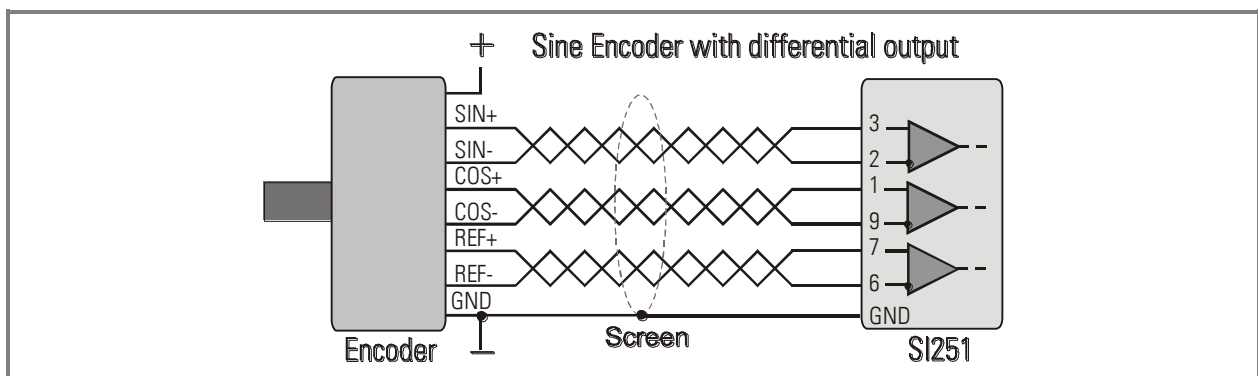
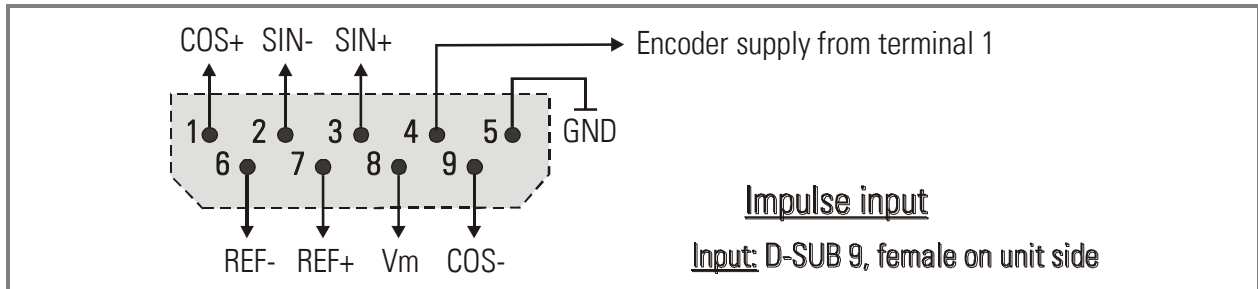

With sensors using single-ended outputs, the sensor signals SIN, COS and REF are connected to the corresponding input pins. The inverted inputs of the unit can be connected either to the mean voltage output V_m (pin 8) of the unit or to a corresponding voltage reference of the sensor itself

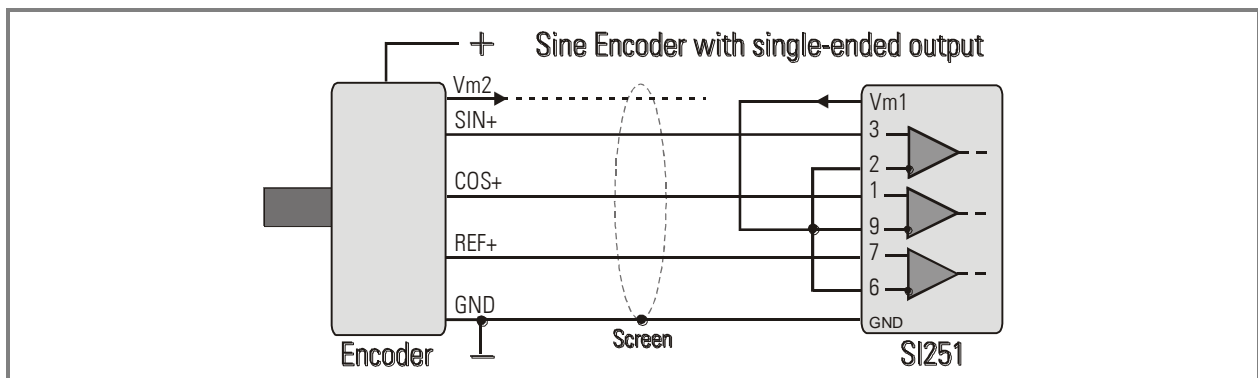

When the reference signals REF+ and REF- are not used or not available, the related inputs of the converter must be tied to a defined potential.

When connecting the REF- pin to V_m with the REF+ pin open, the unit will generate a Z impulse with every sine period.

When connecting the REF+ pin to V_m with the REF- pin open, the unit will not generate a Z impulse.



The sine-cosine signals on the input site are highly sensitive analogue signals! Therefore it is mandatory to use proper screening. Use of cables with pair wise twisted leads is highly recommended. The cable length should not exceed 5 meters if possible.

With critical applications, a terminating impedance (approx. 470 ohms, and where required a capacitor of 680 pF to 4.7 nF) connected between the differential inputs may be helpful.

5.2. RS 422 impulse output

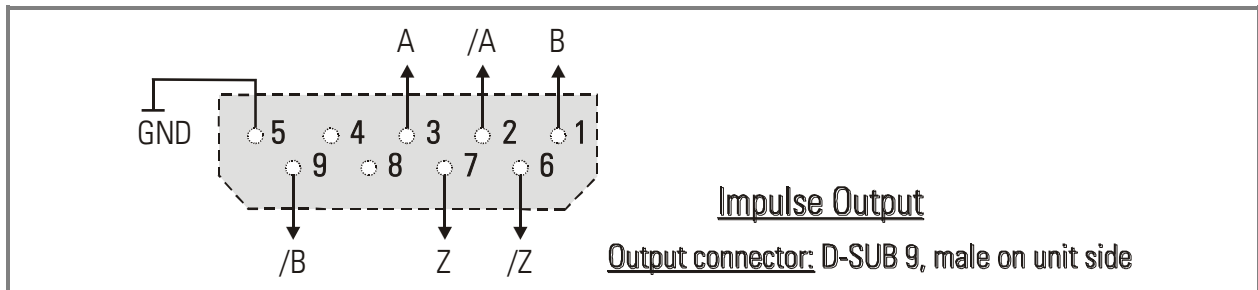

6. Switch settings

Switch DIL1 allows to set the filter and to choose the interpolation rate and interpolation time. Switch DIL2 selects a programmable divider and allows to set the unit to test mode



Changes of the DIL switch positions will become active only after the next power-up of the unit!

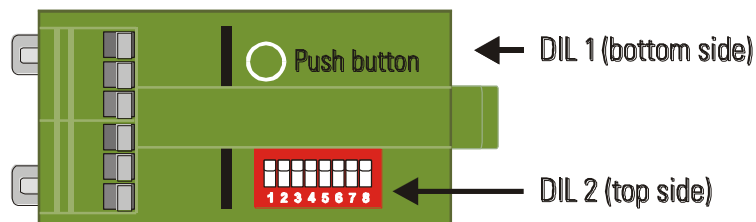

DIL1: (0 = OFF, 1 = ON)								Interpolation and Filtering	
8	7	6	5	4	3	2	1		
						1	1	Minimum Filter	Filtering
						1	0	Filter 10 kHz	
						0	1	Filter 100 kHz	
					1			Glitch-Filter OFF	
					0			Glitch-Filter ON	Interpolation rate
		1	1	1				40	
		1	1	0				20	
		1	0	1				10	
		1	0	0				5	
		0	1	1				50	
		0	1	0				25	
		0	0	1				12,5	
		0	0	0				6,25	
1	1							25 ns	Interpolation time
1	0							100 ns	
0	1							400 ns	
0	0							1600 ns	



Hints for settings of DIL switch 1:

- Under proper electrical conditions there is no imperative need to use the filtering functions offered in the table above. When you set your interpolation factor with use of the filter settings highlighted in the table, there will be no further restrictions with the operating range of the unit.
- Use of the filtering functions will eliminate noise on the signal lines, but at the same time result in some limitations and restrictions of the operating range. The sine input frequency must not exceed the selected filter frequency. Where you decide to use the 100 kHz filter, the unit will not respond to frequencies higher than 100 kHz.
- Distortions of the input signal result in fluctuation of the output frequency.
- Use of the glitch filter results in increased interpolation times at standstill or with low input frequencies, therefore reduces noise and jitter of the output signal by a few increments up and down in standstill. However, when the glitch filter is switched on, fast changes of the speed can result in temporary proportional errors between input frequency and output frequency during acceleration

The subsequent table shows the limits of input and output frequencies with respect to the DIL switch settings:

Interpolation rate	Interpolation time	Maximum output frequency	Maximum input frequency
x5	25 ns	2 MHz	400 kHz
	100 ns	2 MHz	400 kHz
	400 ns	625 kHz	125 kHz
	1600 ns	156.25 kHz	31.25 kHz
x6,25	25 ns	2,5 MHz	400 kHz
	100 ns	2,5 MHz	400 kHz
	400 ns	625 kHz	100 kHz
	1600 ns	156.25 kHz	25 kHz
x10	25 ns	4 MHz	400 kHz
	100 ns	2,5 MHz	250 kHz
	400 ns	625 kHz	62.5 kHz
	1600 ns	156.25 kHz	15.625 kHz

Interpolation rate	Interpolation time	Maximum output frequency	Maximum input frequency
x12,5	25 ns	4 MHz	320 kHz
	100 ns	2.5 MHz	200 kHz
	400 ns	625 kHz	50 kHz
	1600 ns	156.25 kHz	12.5 kHz
x20	25 ns	4 MHz	200 kHz
	100 ns	2.5 MHz	125 kHz
	400 ns	625 kHz	31.25 kHz
	1600 ns	156.25 kHz	7.8125 kHz
x25	25 ns	4 MHz	160 kHz
	100 ns	2.5 MHz	100 kHz
	400 ns	625 kHz	25 kHz
	1600 ns	156.25 kHz	6.25 kHz
x40	25 ns	4 MHz	100 kHz
	100 ns	2.5 MHz	62.5 kHz
	400 ns	625 kHz	15.625 kHz
	1600 ns	156.25 kHz	3.90625 kHz
x50	25 ns	4 MHz	80 kHz
	100 ns	2.5 MHz	50 kHz
	400 ns	625 kHz	12.5 kHz
	1600 ns	156.25 kHz	3.125 kHz

7. Frequency Divider and Error Signals

The programmable frequency divider provides decrease of the output frequency by an adjustable division rate between 1 : 1 and 1 : 128.

The following errors are detected and indicated by the yellow LED and the Error output:

- Wire break with one of the signals SIN+, SIN-, COS+ or COS-
- Too low amplitude on one of above signal lines
- The input frequency exceeds it's maximum level, the output frequency is unable to follow
- The signals REF+ and REF- are not subject of the error check procedure. Depending on the settings on the DIL2 switch, error signals remain active until remote acknowledgement, or reset automatically upon elimination of the error.
- In case of an error the proper function of the unit is not ensured and a loss of encoder pulses can occur.

DIL2: (0 = OFF, 1 = ON)								Divider and testing functions	
8	7	6	5	4	3	2	1		
		1	1	1	1	1	1	1 : 2	Division rate
		1	1	1	1	1	0	1 : 4	
		1	1	1	1	0	1	1 : 6	
		1	1	1	1	0	0	1 : 8	
		1	1	1	0	1	1	1 : 10	
		1	1	1	0	1	0	1 : 12	
		1	1	1	0	0	1	1 : 14	
		1	1	1	0	0	0	1 : 16	
		1	1	0	1	1	1	1 : 18	
-----								-----	
		0	0	0	0	0	0	1 : 128	
	1							Automatic error reset	Error LED and output
	0							Static error message	
0								Divider switched on	Divider
1								Divider switched off	

8. Delays

There is a delay time between the analogue input signals and the incremental output signals, which is typically 3 μ sec. when the divider is switched off. Use of the divider function will extend the delay time correspondingly. The delay time is constant, and causes a frequency dependent phase shift between the input and output signals.

9. Miscellaneous Hints

- The unit will reach full accuracy only after a transient period of approximately 20 full sine cycles at the input. Before that, the input frequency should not exceed about 50 % of the normal maximum frequency
- The application of digital interpolation procedures requires use of quantization steps, which can cause a certain dither of the output signal.
- The quality of the output signal depends essentially on the input signals. Therefore maximum elaborateness is recommended with screening, running of cables and cable length.
- SI251 does not possess a potential separation, i.e. the unit GND is at the same time also GND of the sensor. Therefore it is important to ensure clear conditions with earthing and to prevent earth loops and balance currents flowing through the unit. Where unrulable potential situations should come up, it is recommended to use a fully separate power supply for the SI 251 unit

10. Dimensions

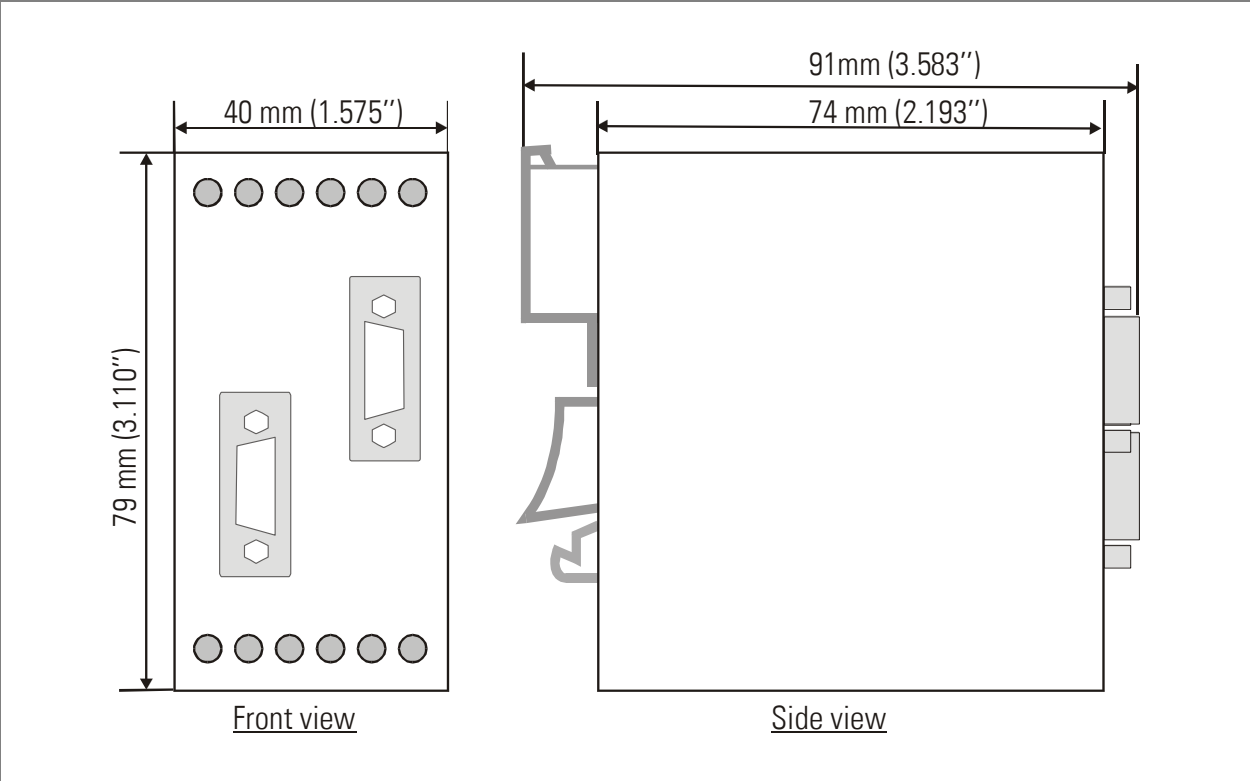

11. Technical Specifications

Power supply:	Input voltage: Protection circuit: Ripple: Consumption: Connections:	18 ... 30 VDC reverse polarity protection ≤ 10 % at 24 VDC approx. 150 mA at 18 V / approx. 90 mA at 30 V (without external load) screw terminal, 1.5 mm ² / AWG 14
Encoder supply:	Number of aux. Voltages: Encoder supply 1: Encoder supply 2: Output current: Connections:	2 + 5.2 VDC power supply (Vdd) minus 4 VDC each max. 150 mA screw terminal, 1.5 mm ² / AWG 14
SinCos input:	Amplitude: DC offset: Channels: Frequency: Differential REF-input signal: Connections:	min. 0.8 Vpp ... max. 1.2 Vpp min. 1.8 V ... max. 3.1 V SIN+, SIN-, COS+, COS-, REF+, REF- max. 400 kHz HIGH 130 mV, LOW 40 mV SUB-D (female), 9-pin
„Error Release“ input:	Signal levels: Internal resistance: Connections:	10 ... 30 V, HTL / PNP, LOW: 0 ... 4 V, HIGH: 10 ... 30 V Ri ≈ 10 kOhm screw terminal, 1.5 mm ² / AWG 14
Incremental output HTL:	Signal level: Channels: Output current: Connections:	power supply (Vdd) minus 4 VDC A, B, Z (push-pull) max. 40 mA screw terminal, 1.5 mm ² / AWG 14
Incremental output TTL / RS422:	Signal levels: Channels: Frequency: Connections:	5 VDC A, /A, B, /B, Z, /Z up to 4 MHz SUB-D (male), 9-pin
„Error“ output	Signal level: Output current: Connections:	HTL, power supply (Vdd) minus 4 VDC max. 40 mA screw terminal, 1.5 mm ² / AWG 14
Housing:	Material: Mounting: Dimensions (w x h x d): Protection class: Weight:	plastic 35 mm top hat rail (according to EN 60715) 40 x 79 x 91 mm / 1.5748 x 3.1102 x 3.5827 inch IP20 approx. 200 g
Ambient temperature:	Operation: Storage:	0 °C ... +45 °C / +32 ... +113 °F (not condensing) -25 °C ... +70 °C / -13 ... +158 °F (not condensing)
Failure rate:	MTBF in years:	40.2 a (long-term usage at 60 °C / 140 °F)
Conformity and standards:	EMC 2004/108/EC: Guideline 2011/65/EU:	EN 61000-6-2, EN 61000-6-3, EN 61000-6-4 RoHS-conform