



SENSECAP

LoRaWAN Gateway and Wireless Sensor Catalog

Version: V1.1



Contents

About SenseCAP.....	3
LoRaWAN Gateway.....	5
LoRaWAN Air Temperature and Humidity Sensor.....	6
LoRaWAN Light Intensity Sensor.....	7
LoRaWAN CO2 Sensor.....	8
LoRaWAN Barometric Pressure Sensor.....	9
LoRaWAN Wind Speed Sensor.....	10
LoRaWAN Wind Direction Sensor.....	11
LoRaWAN Rain Gauge Sensor.....	12
LoRaWAN Soil Moisture and Temperature Sensor.....	13
LoRaWAN Soil Temperature, VWC & EC Sensor.....	14
LoRaWAN pH Sensor.....	15
LoRaWAN PAR Sensor.....	16
SenseCAP Portal.....	17
API Instructions.....	18

System Architecture

SenseCAP Architecture

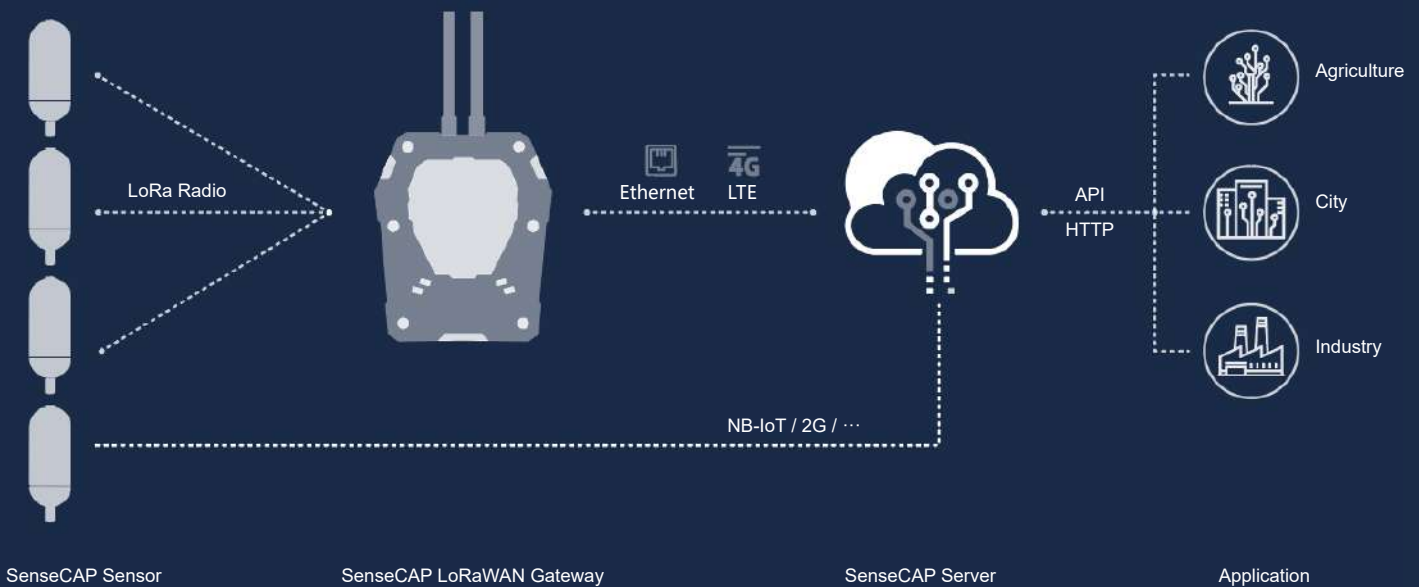

SenseCAP Sensor + Other LoRaWAN Gateway Architecture

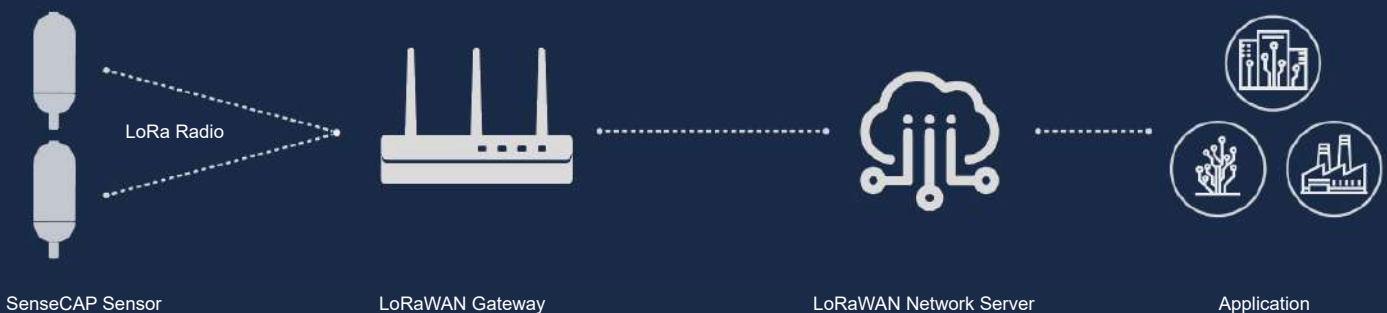

About SenseCAP

SenseCAP is an industrial wireless sensor network that integrates easy-to-deploy hardware and data API services, enabling low-power, long-distance environmental data collection. SenseCAP includes several versions, such as LoRaWAN, NB-IoT, etc.

SenseCAP LoRaWAN version products include LoRaWAN Gateways and Sensor Nodes. Based on LoRaWAN protocol, it can realize one-to-many, long-distance networking and bilateral communication. The LoRaWAN gateway supports Ethernet and 4G. The sensor node is powered by a high-capacity battery that lasts up to 3 years (uploading data once per hour). It also supports hot-swap, making it easy for maintenance and upgrading.

SenseCAP provides an easy-to-use portal. Users can scan the QR code with the App to bind the device with its respective account, manage the devices, and check sensor data on the portal. SenseCAP Portal provides API for users to further develop based on the data on the portal.

Features of SenseCAP LoRaWAN Gateway

- Support LoRaWAN protocol Class A
- Cortex A8 processor, Linux system, stable and reliable
- Ultra-wide-distance transmission: 10km in line of sight scene, 2 km in urban scene
- Support multiple ISM bands: CN470, EU868, US915
- 4G and Ethernet connectivity, suitable for multiple scenes.
- Provides a variety of cloud services and data API interfaces
- Industrial grade protection: IP66 enclosure, suitable for outdoor applications
- Operating temperature -40°C to +70°C



Features of SenseCAP LoRaWAN Sensors

- Support LoRaWAN protocol Class A
- High reliability and stability
- Ultra-wide-distance transmission: 10km in line of sight scene, 2 km in urban scene
- Battery life ≥ 3 years
- Rapid installation and deployment
- IP66 enclosure, suitable for outdoor applications



Application

- Smart Agriculture
- Smart Cities
- Smart Buildings
- Smart Industry
- Environmental Monitoring
- Other Wireless Sensing Applications



SenseCAP LoRaWAN Gateway can only be used with SenseCAP Sensor.

SenseCAP Sensor can be used not only with the SenseCAP LoRaWAN Gateway, but also with other standard LoRaWAN gateways. The Sensor is designed with a fixed LoRa channel, which can not be modified by users. The supported channels are as the follows. Please refer to the user manual for how to connect this device with a LoRaWAN gateway.

CN470	
Uplink	Channels:[80,81,82,83,84,85,86,87] Frequency(MHz): 486.3, 486.5, 486.7, 486.9, 487.1, 487.3, 487.5, 487.7 (SF7BW125 to SF12BW125)
Downlink	Frequency(MHz): 506.7, 506.9, 507.1, 507.3, 507.5, 507.7, 507.9, 508.1 (SF7BW125 to SF12BW125) 505.3 -SF12BW125 (RX2 downlink only)
EU868	
Uplink	Channels: [0,1,2,3,4,5,6,7] Frequency(MHz): 868.1, 868.3, 868.5, 867.1, 867.3, 867.5, 867.7, 867.9 (SF7BW125 to SF12BW125)
Downlink	Multiplexing the frequency points of the 8 uplink channels. 869.525MHz -SF9BW125 (RX2 downlink only)
US915	
Uplink	Channels:[8,9,10,11,12,13,14,15] Frequency(MHz): 903.9, 904.1, 904.3, 904.5, 904.7, 904.9, 905.1, 905.3 (SF7BW125 to SF10BW125)
Downlink	Frequency(MHz): 923.3, 923.9, 924.5, 925.1, 925.7, 926.3, 926.9, 927.5 (SF7BW500 to SF12BW500)



LoRaWAN Gateway



Specifications

Product Model			
Model	Region		
LoRa-G-470-E/4G	Asia(China)		
LoRa-G-868-E/4G	European, Africa, Asia(India etc.)		
LoRa-G-915-E/4G	North America, South America, Oceania,Asia(Japan, Korea, Thailand, etc.)		
LoRa Parameters			
Protocol	Based on LoRaWAN v1.0.2 protocol		
Channel Plan	470~510MHz	863~870MHz	902~928MHz
Power Output	24dBm	25dBm	25dBm
Sensitivity	-140dBm (SF12BW125)	-139dBm (SF12BW125)	-139dBm (SF12BW125)
General Parameters			
CPU	TI AM3358 Cortex-A8 1GHz		
System	Linux Debian		
RAM	DDR3 512MB		
Memory	8GB eMMC		
Ethernet	100Mbps FE (RJ-45)		
4G Band	LTE-FDD: B1/B2/B3/B4/B5/B7/B8/B12/B13/B18/B19/B20/B25/B26/B28 LTE-TDD: B38/B39/B40/B41 WCDMA: B1/B2/B4/B5/B6/B8/B19 GSM: 850/900/1800/1900MHz		
4G Features	Support non-CA Cat 4 FDD and TDD LTE-FDD: Max 150Mbps (DL), Max 50Mbps (UL) LTE-TDD: Max 130Mbps (DL), Max 30Mbps (UL)		

Introduction

SenseCAP LoRaWAN Gateway(*) is based on LoRaWAN®(**) protocol, applicable for low-power, long-distance environmental data collection and monitoring in scenarios such as smart agriculture and smart city etc. As the central device of the LoRa network, the gateway is used for collecting data from different Sensor Node and transmit the data to the SenseCAP Portal via 4G or Ethernet cable. Equipped with a high-performance processor and telecom-operator-level LoRa chip, this gateway ensures stable and high performance in large-scale network. The gateway is designed with IP66-protection-level enclosure, making it suitable for industrial applications in outdoor severe environments.

General Parameters	
UMTS Features	Support 3GPP R8 DC-HSDPA, HSPA+, HSDPA, HSUPA and WCDMA DC-HSDPA: Max 42Mbps (DL) HSUPA: Max 5.76Mbps (UL) WCDMA: Max 384Kbps (DL), Max 384Kbps (UL)
LoRa Antenna	CN470: 0.5dBi gain / Vertical polarization / Omni-directional / SMA-J connector EU868: 2.5dBi gain / Vertical polarization / Omni-directional / SMA-J connector US915: 2.5dBi gain / Vertical polarization / Omni-directional / SMA-J connector
4G Antenna	0-4 dBi gain / Linear polarization / Omni-directional / SMA-J connector
LED Indicator	Indicating network condition (online/offline)
Grounding	Reserved 1 screw hole for GND
Power Consumption	3.6W
Power Supply	DC 12V/2A
IP Rating	IP66
UV Resistance	anti-aging (from rain/sun exposure): UL746C F1
Enclosure Material	PC
Operating Temperature	-40 °C to +70 °C
Operating Humidity	0 to 100 %RH (non-condensing)
Installation Method	Wall or pole mounting
Device Weight	777g

Device Dimensions

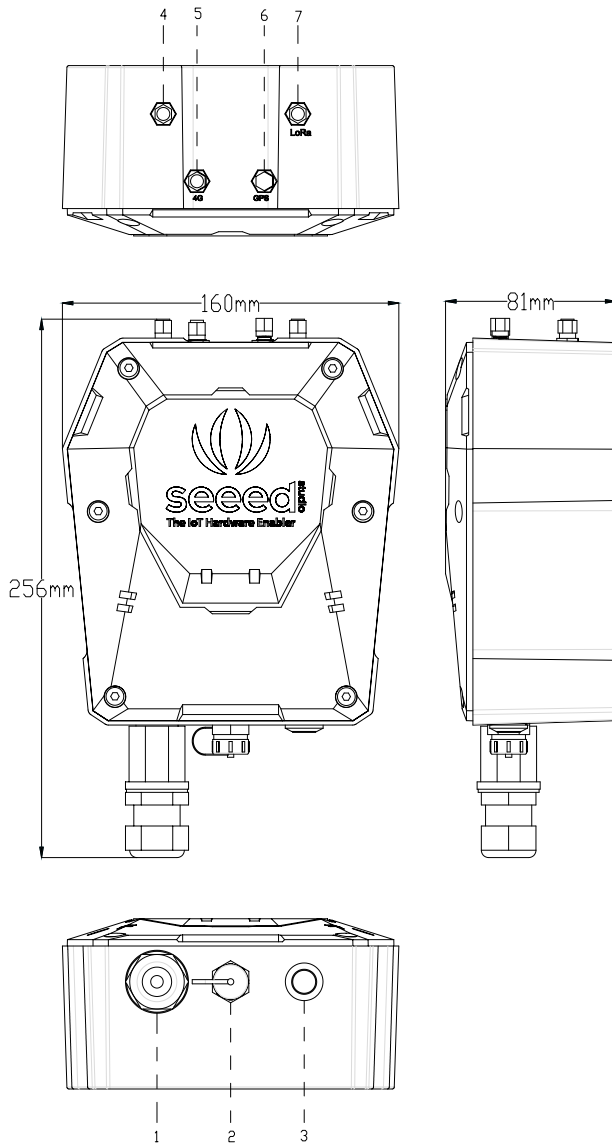

- 1. Ethernet Port
- 2. Power Connector
- 3. LED
- 4. Reserved
- 5. 4G Antenna Connector
- 6. Reserved
- 7. LoRa Antenna Connector

Certification



** The LoRaWAN® name and associated logo are trademarks of Semtech Corporation or its subsidiaries.
* SenseCAP LoRaWAN Gateway can only be used with SenseCAP Sensor.



LoRaWAN Air Temperature and Humidity Sensor

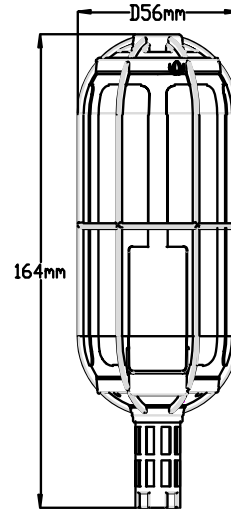

Specifications

Air Temperature	
Range	-40 °C to +85 °C
Accuracy	±0.2 °C
Resolution	0.1 °C
Drift	< 0.03 °C /year
Air Humidity	
Range	0 to 100 %RH (non-condensing)
Accuracy	±1.5 %RH
Resolution	1 %RH
Drift	< 0.25 %RH/year
General Parameters	
Product Model	LoRa-S-470/868/915-TH-01
Microcontroller	Ultra-low-power MCU
Support Protocol	Based on LoRaWAN v1.0.2 protocol
LoRa Channel Plan	CN470 / EU868 / US915
LoRa Power Output	16 dBm (EIRP)
Sensitivity	470MHz: -140dBm(SF12, BW125KHz) 868MHz: -137.5dBm(SF12, BW125KHz) 915MHz: -136.5dBm(SF12, BW125KHz)
Current Consumption	5 µA (sleep mode) 120 mA (active mode)
Communication Distance	2 to 10 km (depending on different antennas and environments)
Battery Life	≥ 3 year (upload data once per hour)
Battery Voltage	3.6V
Battery Capacity	19Ah (Non-rechargeable)
IP Rating	IP66
UV Resistance	anti-aging (from rain/sun exposure): UL746C F1
Enclosure Material	PC
Operating Temperature	-40 °C to +85 °C
Operating Humidity	0 to 100 %RH (non-condensing)
Device Weight	236g

Installation

Please refer to the user manual for more details.

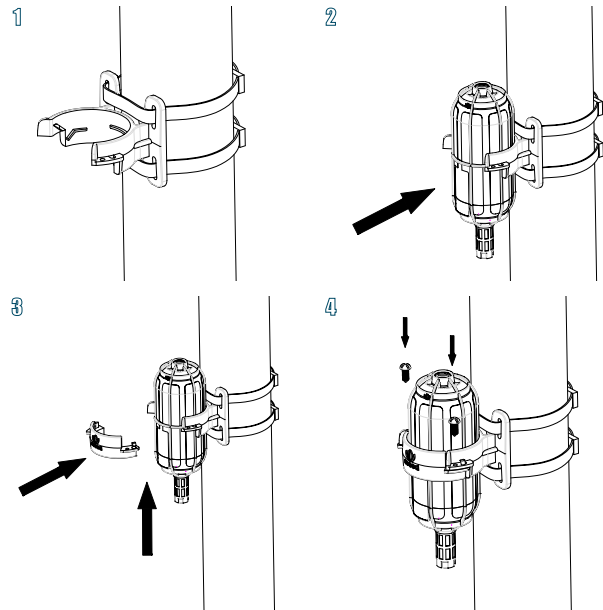

Certification





LoRaWAN Light Intensity Sensor

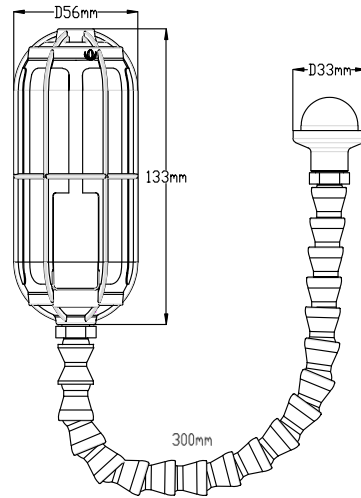

Specifications

Light Intensity	
Range	0 to 188000 Lux
Sensitivity	0.045 Lux/LSB
Resolution	0.045 Lux
General Parameters	
Product Model	LoRa-S-470/868/915-Light Intensity-01
Microcontroller	Ultra-low-power MCU
Support Protocol	Based on LoRaWAN v1.0.2 protocol
LoRa Channel Plan	CN470 / EU868 / US915
LoRa Power Output	16 dBm (EIRP)
Sensitivity	470MHz: -140dBm(SF12, BW125KHz) 868MHz: -137.5dBm(SF12, BW125KHz) 915MHz: -136.5dBm(SF12, BW125KHz)
Current Consumption	5 μ A (sleep mode) 120 mA (active mode)
Communication Distance	2 to 10 km (depending on different antennas and environments)
Battery Life	\geq 3 year (upload data once per hour)
Battery Voltage	3.6V
Battery Capacity	19Ah (Non-rechargeable)
IP Rating	IP66
UV Resistance	anti-aging (from rain/sun exposure): UL746C F1
Enclosure Material	PC
Operating Temperature	-40 $^{\circ}$ C to +85 $^{\circ}$ C
Operating Humidity	0 to 100 %RH (non-condensing)
Device Weight	288g

Installation

Please refer to the user manual for more details.

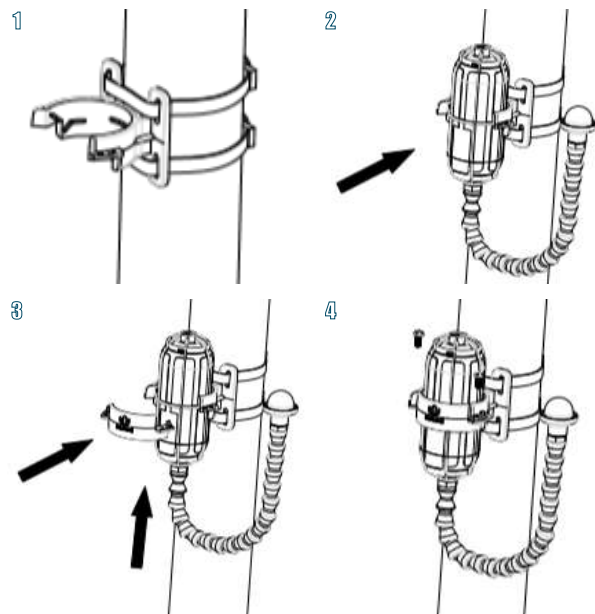

Certification





LoRaWAN CO2 Sensor

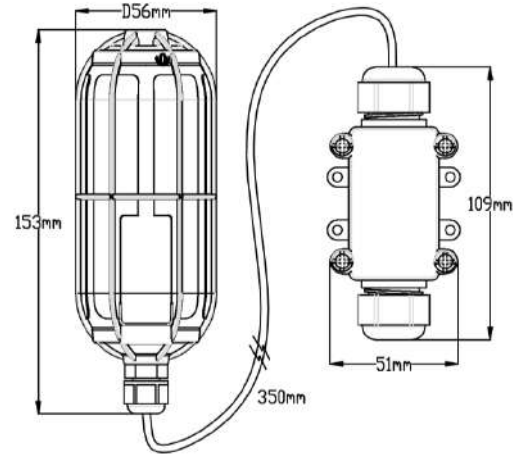

Specifications

CO2

Parameters	Condition	Value
Range	-	0 to 40000 ppm
Accuracy	400 to 10000ppm	±(30 ppm + 3 %MV)
Resolution	-	1 ppm
Temperature Stability	T = 0 to 50 °C 400 to 10000 ppm	±2.5 ppm / °C

General Parameters

Product Model	LoRa-S-470/868/915-CO2-01
Microcontroller	Ultra-low-power MCU
Support Protocol	Based on LoRaWAN v1.0.2 protocol
LoRa Channel Plan	CN470 / EU868 / US915
LoRa Power Output	16 dBm (EIRP)
Sensitivity	470MHz: -140dBm(SF12, BW125KHz) 868MHz: -137.5dBm(SF12, BW125KHz) 915MHz: -136.5dBm(SF12, BW125KHz)
Current Consumption	5 µA (sleep mode) 120 mA (active mode)
Communication Distance	2 to 10 km (depending on different antennas and environments)
Battery Life	≥ 3 year (upload data once per hour)
Battery Voltage	3.6V
Battery Capacity	19Ah (Non-rechargeable)
IP Rating	IP66
UV Resistance	anti-aging (from rain/sun exposure): UL746C F1
Enclosure Material	PC
Operating Temperature	0 °C to +50 °C
Operating Humidity	0 to 95 %RH
Device Weight	319g

Installation

Please refer to the user manual for more details.

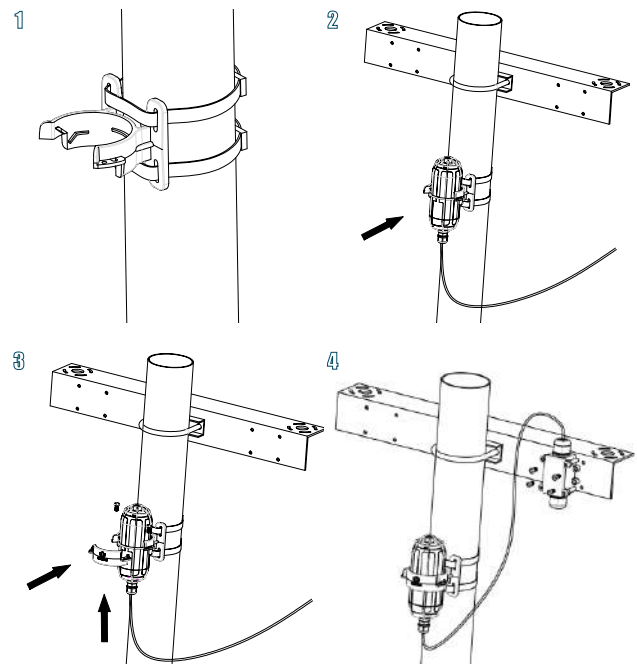

Certification





LoRaWAN Barometric Pressure Sensor

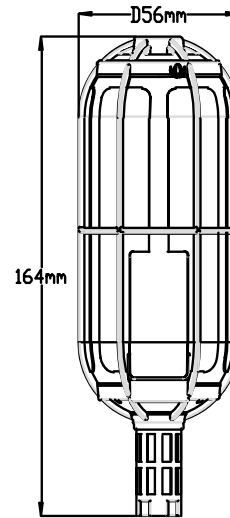

Specifications

Barometric Pressure		
Parameters	Condition	Value
Range	-	300~1100 hPa
Resolution	-	1 Pa
Relative Accuracy	700 to 900 hPa 25 to 40 °C	±0.12 hPa
Absolute Accuracy	300 to 1100 hPa -20 to 0 °C	±1.7 hPa
Absolute Accuracy	300 to 1100 hPa 0 to 65 °C	±1.0 hPa
Temperature Coefficient Offset	900 hPa 25 to 40 °C	1.5 Pa/K
Drift	-	±1.0 hPa/year
General Parameters		
Product Model	LoRa-S-470/868/915-Baro-01	
Microcontroller	Ultra-low-power MCU	
Support Protocol	Based on LoRaWAN v1.0.2 protocol	
LoRa Channel Plan	CN470 / EU868 / US915	
LoRa Power Output	16 dBm (EIRP)	
Sensitivity	470MHz: -140dBm(SF12, BW125KHz) 868MHz: -137.5dBm(SF12, BW125KHz) 915MHz: -136.5dBm(SF12, BW125KHz)	
Current Consumption	5 μA (sleep mode) 120 mA (active mode)	
Communication Distance	2 to 10 km (depending on different antennas and environments)	
Battery Life	≥ 3 year (upload data once per hour)	
Battery Voltage	3.6V	
Battery Capacity	19Ah (Non-rechargeable)	
IP Rating	IP66	
UV Resistance	anti-aging (from rain/sun exposure): UL746C F1	

Installation

Please refer to the user manual for more details.

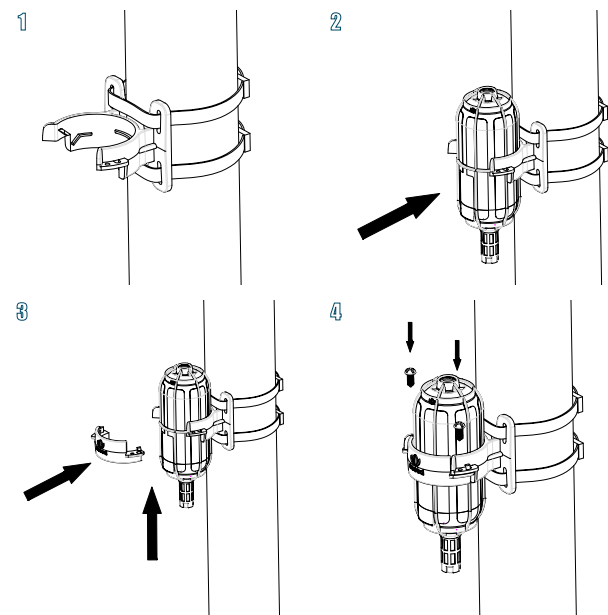

General Parameters	
Enclosure Material	PC
Operating Temperature	-40 to +85 °C (full accuracy: 0 to 65°C)
Operating Humidity	0 to 100 %RH (non-condensing)
Device Weight	237g

Certification





LoRaWAN Wind Speed Sensor

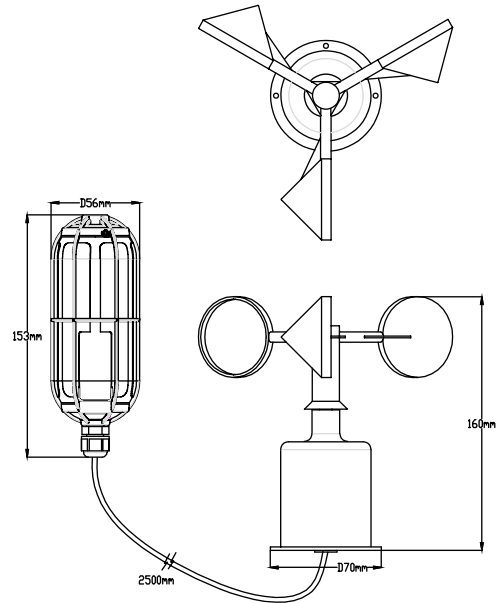

Specifications

Wind Speed	
Range	0 to 60 m/s
Accuracy	±0.3 m/s
Resolution	0.1 m/s
General Parameters	
Product Model	LoRa-S-470/868/915-Wind Speed-01
Microcontroller	Ultra-low-power MCU
Support Protocol	Based on LoRaWAN v1.0.2 protocol
LoRa Channel Plan	CN470 / EU868 / US915
LoRa Power Output	16 dBm (EIRP)
Sensitivity	470MHz: -140dBm(SF12, BW125KHz) 868MHz: -137.5dBm(SF12, BW125KHz) 915MHz: -136.5dBm(SF12, BW125KHz)
Current Consumption	5 µA (sleep mode) 120 mA (active mode)
Communication Distance	2 to 10 km (depending on different antennas and environments)
Battery Life	≥ 3 year (upload data once per hour)
Battery Voltage	3.6V
Battery Capacity	19Ah (Non-rechargeable)
IP Rating	IP66
UV Resistance	anti-aging (from rain/sun exposure): UL746C F1
Enclosure Material	PC
Operating Temperature	-40 °C to +50 °C
Operating Humidity	0 to 100 %RH (non-condensing)
Device Weight	490g

Installation

Please refer to the user manual for more details.

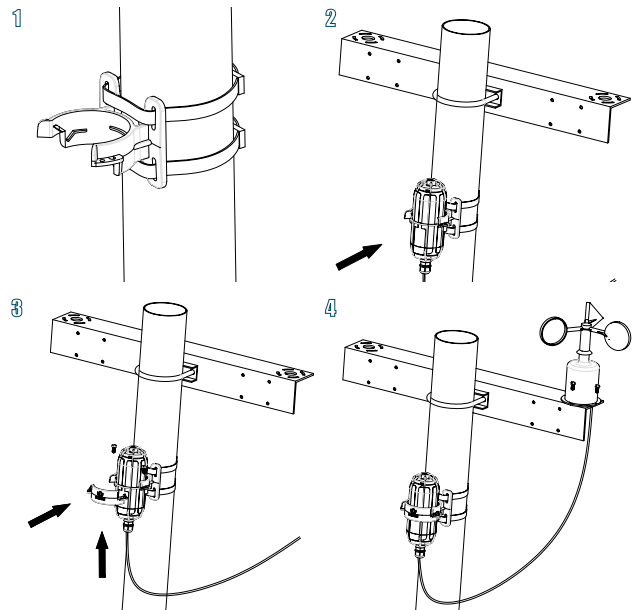

Certification





LoRaWAN Wind Direction Sensor

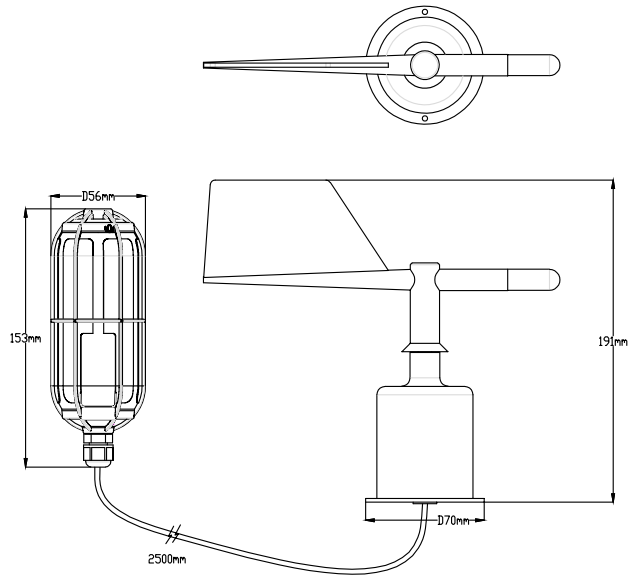

Specifications

Wind Direction	
Range	0° to 360°
Accuracy	±3°
Resolution	1°
General Parameters	
Product Model	LoRa-S-470/868/915-Wind Direction-01
Microcontroller	Ultra-low-power MCU
Support Protocol	Based on LoRaWAN v1.0.2 protocol
LoRa Channel Plan	CN470 / EU868 / US915
LoRa Power Output	16 dBm (EIRP)
Sensitivity	470MHz: -140dBm(SF12, BW125KHz)
	868MHz: -137.5dBm(SF12, BW125KHz)
	915MHz: -136.5dBm(SF12, BW125KHz)
Current Consumption	5 μA (sleep mode)
	120 mA (active mode)
Communication Distance	2 to 10 km (depending on different antennas and environments)
Battery Life	≥ 3 year (upload data once per hour)
Battery Voltage	3.6V
Battery Capacity	19Ah (Non-rechargeable)
IP Rating	IP66
UV Resistance	anti-aging (from rain/sun exposure): UL746C F1
Installation	Point the slot on the casing to the south
Enclosure Material	PC
Operating Temperature	-40 °C to +50 °C
Operating Humidity	0 to 100 %RH (non-condensing)
Device Weight	518g

Installation

Please refer to the user manual for more details.

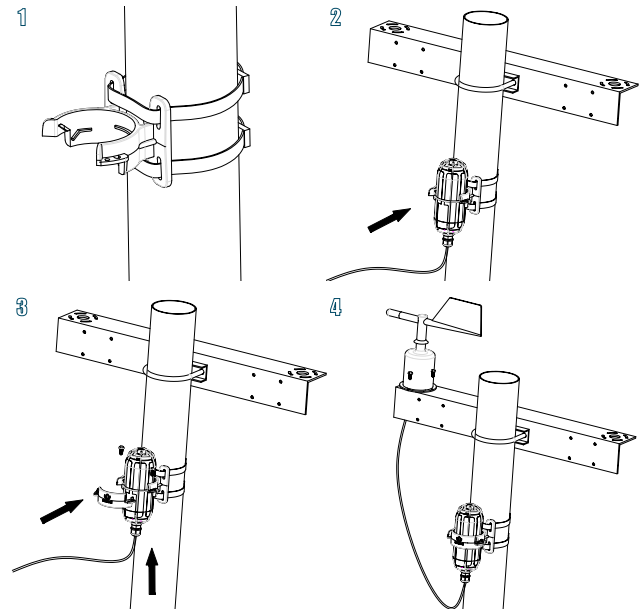

Certification





LoRaWAN Rain Gauge Sensor

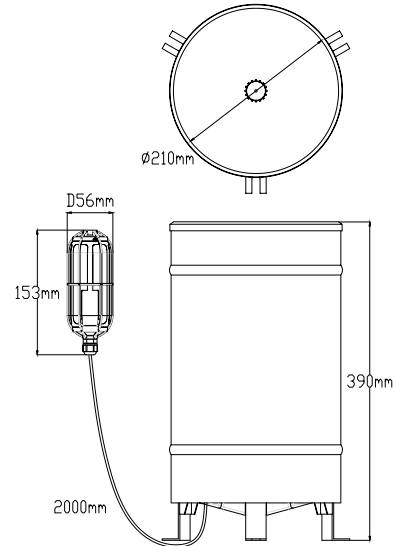

Specifications

Rainfall Volume	
Range	0~240 mm/hour
Accuracy	≤ ±2%
Resolution	0.5 mm/hour
General Parameters	
Product Model	LoRa-S-470/868/915-Rain-01
Microcontroller	Ultra-low-power MCU
Support Protocol	Based on LoRaWAN v1.0.2 protocol
LoRa Channel Plan	CN470 / EU868 / US915
LoRa Power Output	16 dBm (EIRP)
Sensitivity	470MHz: -140dBm(SF12, BW125KHz) 868MHz: -137.5dBm(SF12, BW125KHz) 915MHz: -136.5dBm(SF12, BW125KHz)
Current Consumption	5 μA (sleep mode) 120 mA (active mode)
Communication Distance	2 to 10 km (depending on different antennas and environments)
Battery Life	≥ 3 year (upload data once per hour)
Battery Voltage	3.6V
Battery Capacity	19Ah (Non-rechargeable)
IP Rating	IP66
UV Resistance	anti-aging (from rain/sun exposure): UL746C F1
Enclosure Material	PC
Operating Temperature	0 °C to +50 °C
Operating Humidity	0 to 95 %RH
Device Weight	2.3kg

Installation

Please refer to the user manual for more details.

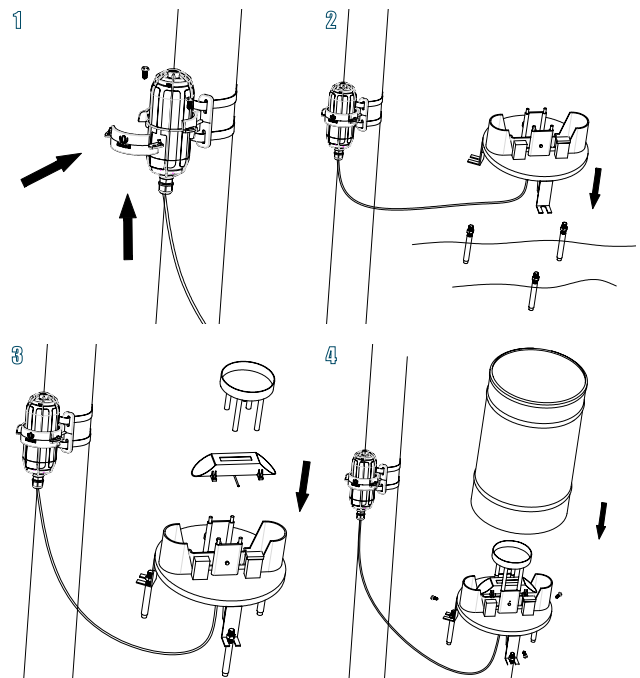

Certification





LoRaWAN Soil Moisture and Temperature Sensor

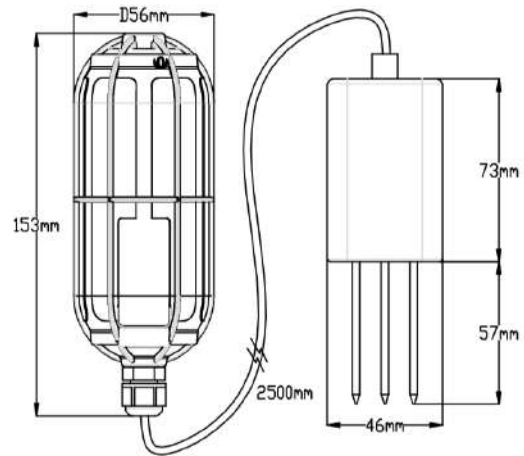

Specifications

Soil Temperature	
Range	-30 °C to +70 °C
Accuracy	±0.2 °C
Resolution	0.01 °C
Soil Moisture	
Range	From completely dry to fully saturated (from 0% to 100% of saturation)
Accuracy	±2% (0 to 50 %(m ³ /m ³))
Resolution	0.01 %(m ³ /m ³)
General Parameters	
Product Model	LoRa-S-470/868/915-Soil MT-01
Microcontroller	Ultra-low-power MCU
Support Protocol	Based on LoRaWAN v1.0.2 protocol
LoRa Channel Plan	CN470 / EU868 / US915
LoRa Power Output	16 dBm (EIRP)
Sensitivity	470MHz: -140dBm(SF12, BW125KHz) 868MHz: -137.5dBm(SF12, BW125KHz) 915MHz: -136.5dBm(SF12, BW125KHz)
Current Consumption	5 μA (sleep mode) 120 mA (active mode)
Communication Distance	2 to 10 km (depending on different antennas and environments)
Measuring Area	A cylinder area (with the probe as the center, diameter: 7cm, height: 7cm)
Battery Life	≥ 3 year (upload data once per hour)
Battery Voltage	3.6V
Battery Capacity	19Ah (Non-rechargeable)
IP Rating	IP66
UV Resistance	anti-aging (from rain/sun exposure): UL746C F1
Enclosure Material	PC
Operating Temperature	-30 °C to +70 °C
Operating Humidity	0 to 100 %RH (non-condensing)
Device Weight	415g

Installation

Please refer to the user manual for more details.

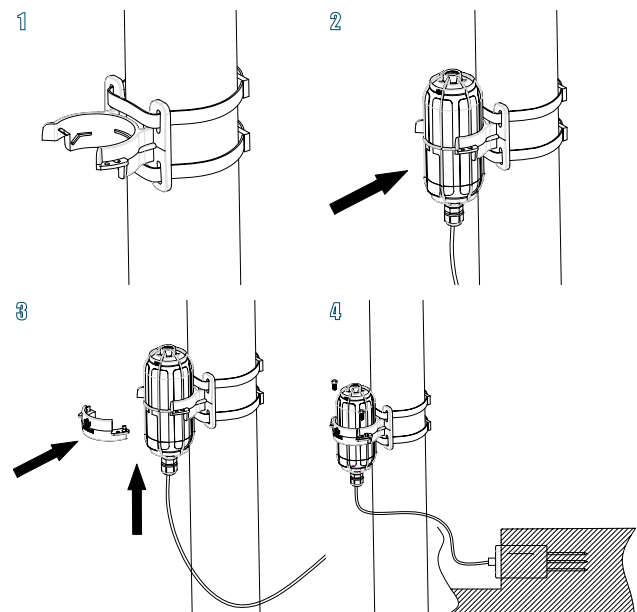

Certification





LoRaWAN Soil Temperature & VWC & EC Sensor

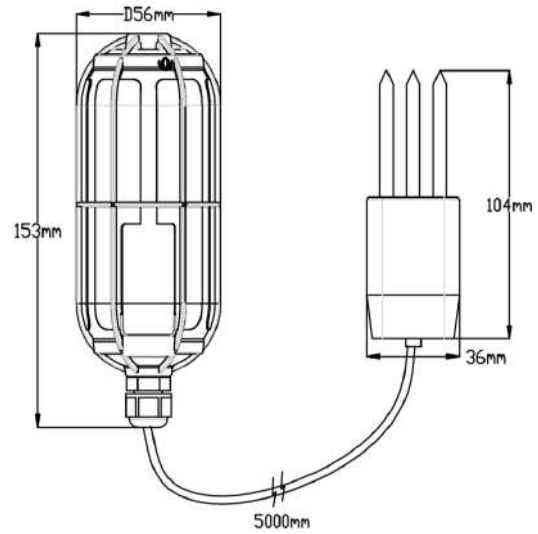

Specifications

Soil Temperature	
Range	-40 °C to +60 °C
Accuracy	±1 °C
Resolution	0.1 °C
Soil Volumetric Water Content	
Range	From completely dry to fully saturated (from 0% to 100% of saturation)
Accuracy	±3 %(m ³ /m ³) typical
Resolution	0.08 %(m ³ /m ³)
Soil Electrical Conductivity	
Range	0 to 23 dS/m (bulk)
Accuracy	±10% (0~7dS/m), user calibration required from 7~23 dS/m
Resolution	0.01 dS/m (0~7dS/m) 0.05 dS/m (7~23dS/m)
General Parameters	
Product Model	LoRa-S-470/868/915-Soil Temp&VWC&EC-01
Microcontroller	Ultra-low-power MCU
Support Protocol	Based on LoRaWAN v1.0.2 protocol
LoRa Channel Plan	CN470 / EU868 / US915
LoRa Power Output	16 dBm (EIRP)
Sensitivity	470MHz: -140dBm(SF12, BW125KHz) 868MHz: -137.5dBm(SF12, BW125KHz) 915MHz: -136.5dBm(SF12, BW125KHz)
Current Consumption	5 µA (sleep mode) 120 mA (active mode)
Communication Distance	2 to 10 km (depending on different antennas and environments)
Battery Life	≥ 3 year (upload data once per hour)
Battery Voltage	3.6V
Battery Capacity	19Ah (Non-rechargeable)
IP Rating	IP66

Installation

Please refer to the user manual for more details.

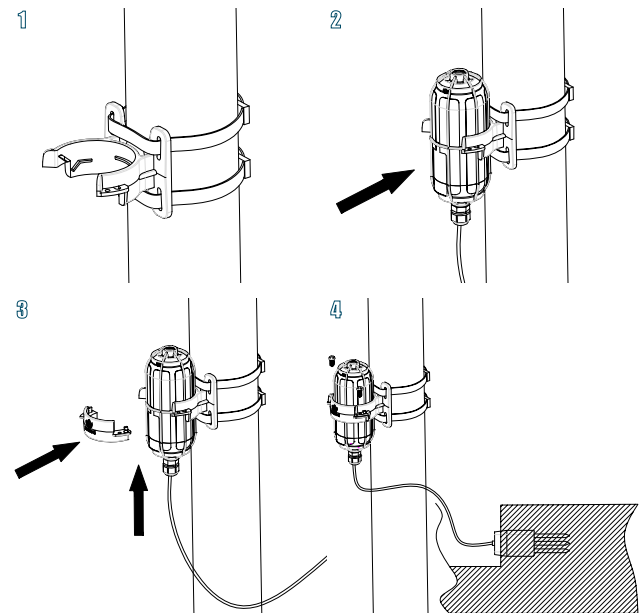

General Parameters	
UV Resistance	anti-aging (from rain/sun exposure): UL746C F1
Enclosure Material	PC
Operating Temperature	-40 °C to +60 °C
Operating Humidity	0 to 100 %RH (non-condensing)
Device Weight	385g

Certification





LoRaWAN pH Sensor

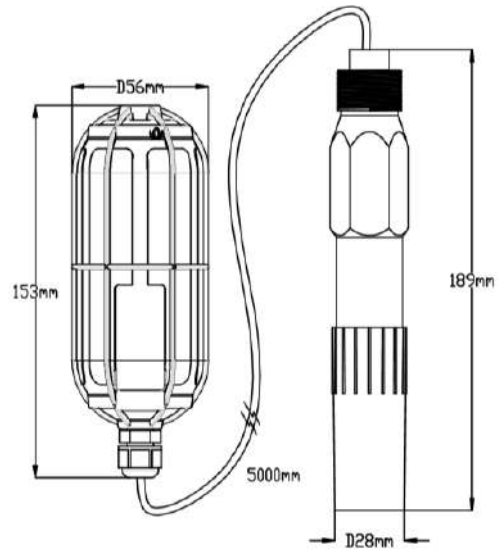

Specifications

pH	
Range	0~14 pH
Accuracy	±0.1 pH
Resolution	0.1 pH
General Parameters	
Product Model	LoRa-S-470/868/915-pH-01
Microcontroller	Ultra-low-power MCU
Support Protocol	Based on LoRaWAN v1.0.2 protocol
LoRa Channel Plan	CN470 / EU868 / US915
LoRa Power Output	16 dBm (EIRP)
Sensitivity	470MHz: -140dBm(SF12, BW125KHz) 868MHz: -137.5dBm(SF12, BW125KHz) 915MHz: -136.5dBm(SF12, BW125KHz)
Current Consumption	5 μA (sleep mode) 120 mA (active mode)
Communication Distance	2 to 10 km (depending on different antennas and environments)
Battery Life	≥ 3 year (upload data once per hour)
Battery Voltage	3.6V
Battery Capacity	19Ah (Non-rechargeable)
IP Rating	IP66
UV Resistance	anti-aging (from rain/sun exposure): UL746C F1
Enclosure Material	PC
Operating Temperature	-20 °C to +50 °C
Operating Humidity	0 to 100 %RH (non-condensing)
Device Weight	594g

Installation

Please refer to the user manual for more details.

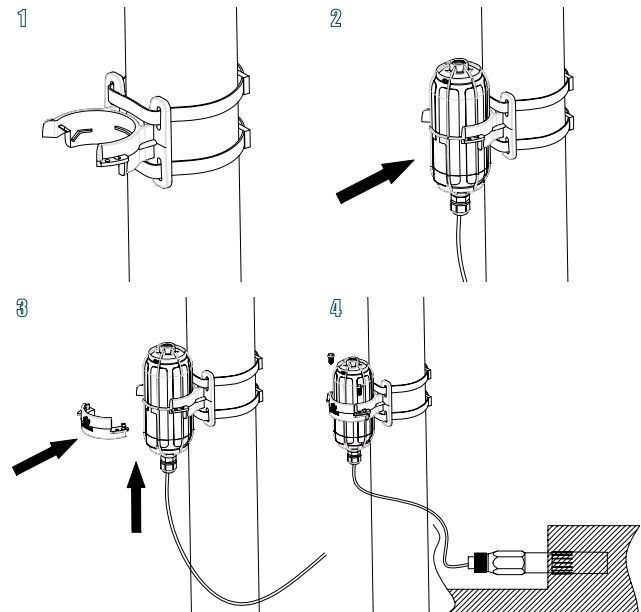

Certification





LoRaWAN PAR Sensor

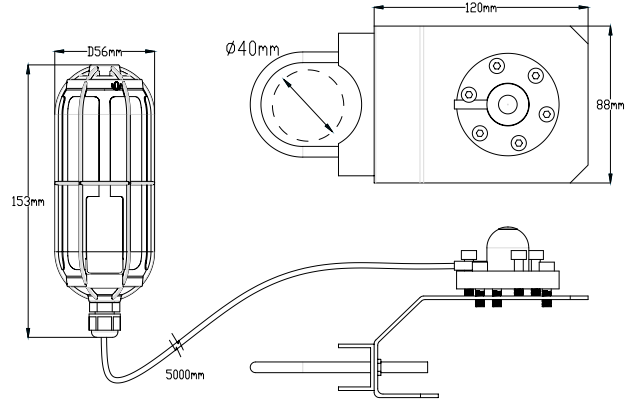

Specifications

Photosynthetically Active Radiation	
Range	0 to 2000 $\mu\text{mol m}^{-2} \text{s}^{-1}$ (410 to 655 nm)
Sensitivity	0.2 mV/ $\mu\text{mol m}^{-2} \text{s}^{-1}$
Resolution	1 $\mu\text{mol m}^{-2} \text{s}^{-1}$
Non-stability (Long-term Drift)	< 2% / year
Measurement Repeatability	< 1 %
Field of View	180°
General Parameters	
Product Model	LoRa-S-470/868/915-PAR-01
Microcontroller	Ultra-low-power MCU
Support Protocol	Based on LoRaWAN v1.0.2 protocol
LoRa Channel Plan	CN470 / EU868 / US915
LoRa Power Output	16 dBm (EIRP)
Sensitivity	470MHz: -140dBm(SF12, BW125KHz) 868MHz: -137.5dBm(SF12, BW125KHz) 915MHz: -136.5dBm(SF12, BW125KHz)
Current Consumption	5 μA (sleep mode) 120 mA (active mode)
Communication Distance	2 to 10 km (depending on different antennas and environments)
Battery Life	≥ 3 year (upload data once per hour)
Battery Voltage	3.6V
Battery Capacity	19Ah (Non-rechargeable)
IP Rating	IP66
UV Resistance	anti-aging (from rain/sun exposure): UL746C F1
Enclosure Material	PC
Operating Temperature	-40 °C to +70 °C
Operating Humidity	0 to 100 %RH (non-condensing)
Device Weight	326g

Installation

Please refer to the user manual for more details.

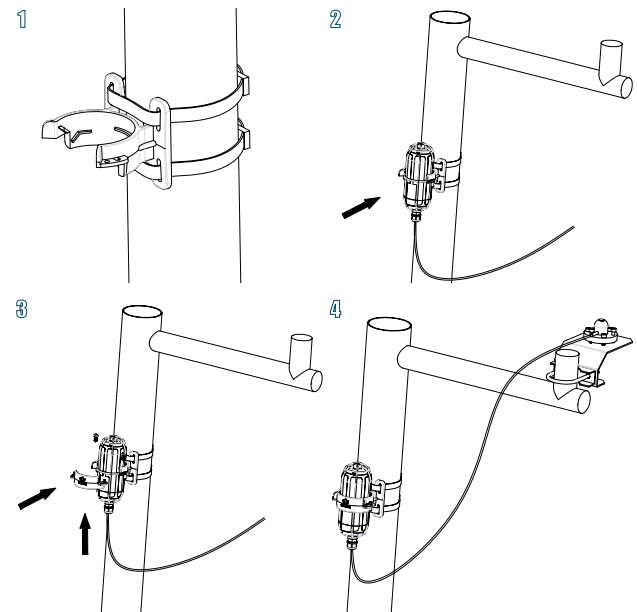

Certification



SenseCAP Application

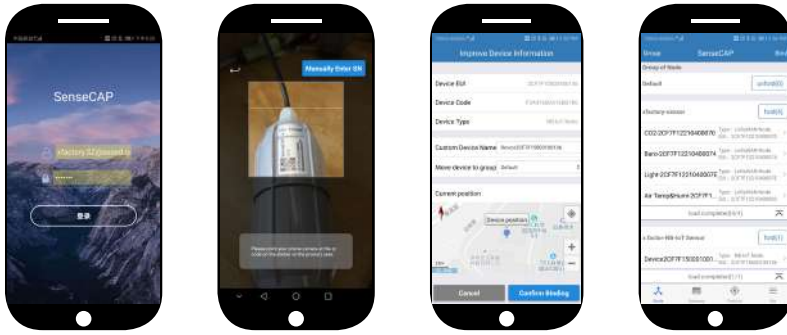

SenseCAP App is used to bind devices to your account and check device information.

Download Application:
For iOS, please search for "SenseCAP" in App Store and download.

For Android, please download SenseCAP Application from <https://www.pgyer.com/sensecap>



SenseCAP Portal

SenseCAP Portal is a web-based platform which enables

- Device management
- Data management
- API Access Key management

Visit SenseCAP Portal: <https://sensecap.seeed.cc>

For more info, please visit: <https://solution.seeed.cc/product/sensecap>

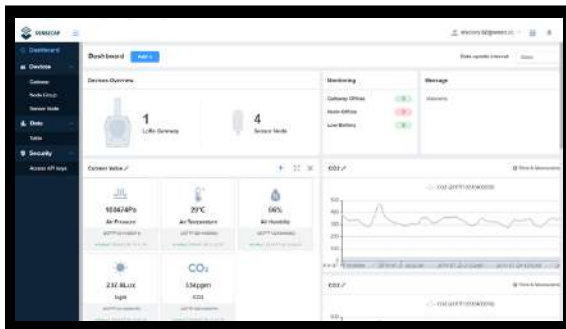

Dashboard

Including Device Overview, Data Upload Interval, Announcement, Scene Data, and Data Chart, etc.

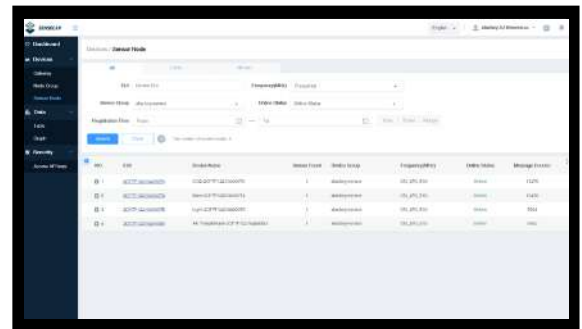

Device Management

Manage SenseCAP devices

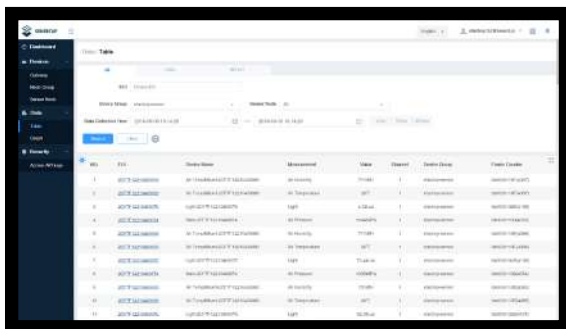

Data Management

Manage data, including Data Table and Graph section, providing methods to search for data.

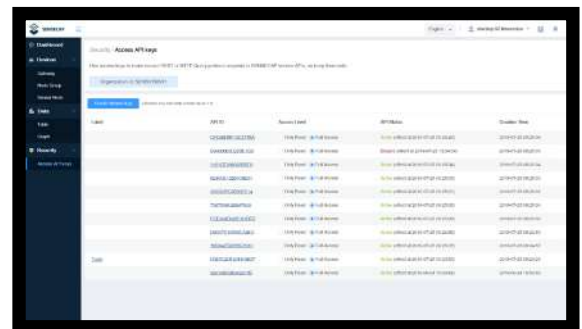

Access Key Management

Manage Access Key (to access API service), including: Key Create, Key Update, and Key Check.

Application Programming Interface (API) Instructions

SenseCAP also provides API to support further development.
Please visit this link for more info: <https://sensecap.gitbook.io/doc/>

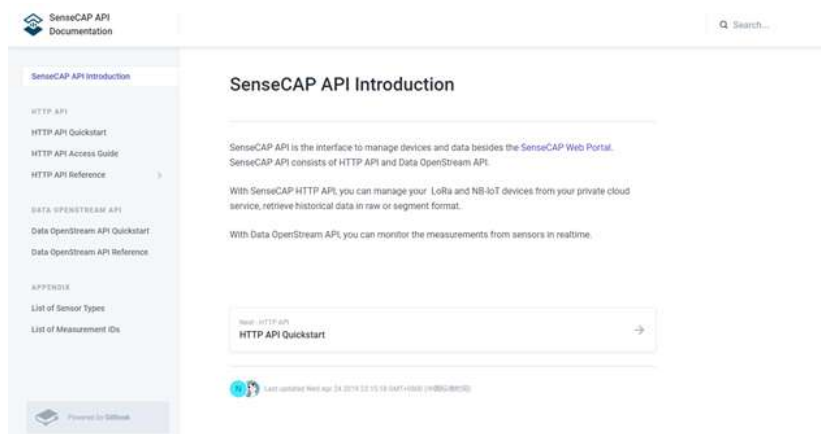

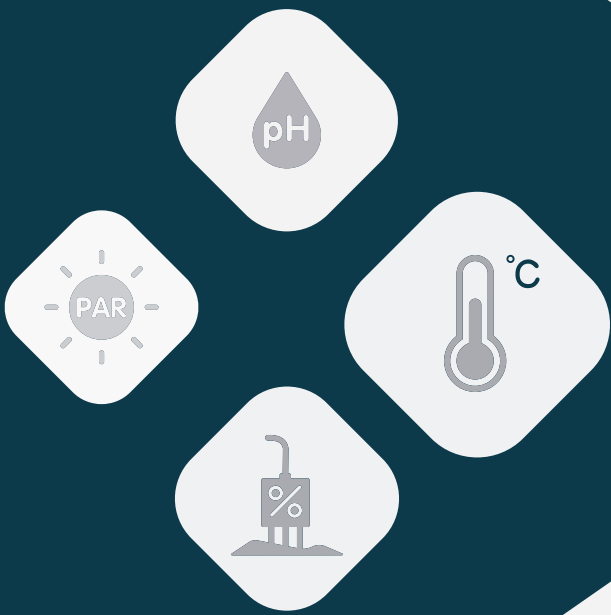

© 2008-2019 Seeed Technology Co., Ltd. All rights reserved.

CONTACT

Website: solution.seeed.cc
Sales: iot@seeed.cc
Support: sensecap@seeed.cc
Phone: +86 755 3653 4305