

LoRaWAN Gateway Kit



LoRa is a perfect long-range wireless solution to create low-power, wide area networks. So far we have released several "LoRa" boards such as Seeeduno LoRaWAN and Grove LoRa Radio etc. However if you want to build your own LoRa network, there are 3 things that you should prepare to get started: a Gateway, at least one Node and a local server where you can monitor all your devices.

This kit provides all the basic elements you need: a Raspberry Pi 3, a Seeeduno LoRaWAN with GPS and a gateway & local server that allows you to collect and transfer data among all your LoRa nodes. By connecting the gateway with Seeeduno LoRaWAN and Grove modules, you can build your IOT prototype within minutes.

Regarding the gateway module RHF0M301, it is a 10 channel (8 x Multi-SF + 1 x Standard LoRa + 1 x FSK) LoRaWAN gateway module with a 24pin DIP port on board, users can easily connect the RHF0M301 with PRI 2 bridge RHF4T002, adapter for Raspberry Pi 3 and RHF0M301. We also included a 868MHz antenna, an 8GB SD card and USB cables, Ethernet Cables and other accessories.

Caution

Please always plug 3.7V Lipo battery in case USB power supply is not sufficient. This wiki works for both 868MHz kit and 915MHz kit.

868MHz Kit for Raspberry Pi 3

Get One Now 

915MHz Kit for Raspberry Pi 3

Get One Now 

Features

- Low power consumption & wide area
- Industrial standard reliability
- Economic solution to build LoRa /LoRaWAN network
- Rich Accessories of sensor and actuator
- Real time monitoring

Hardware Overview

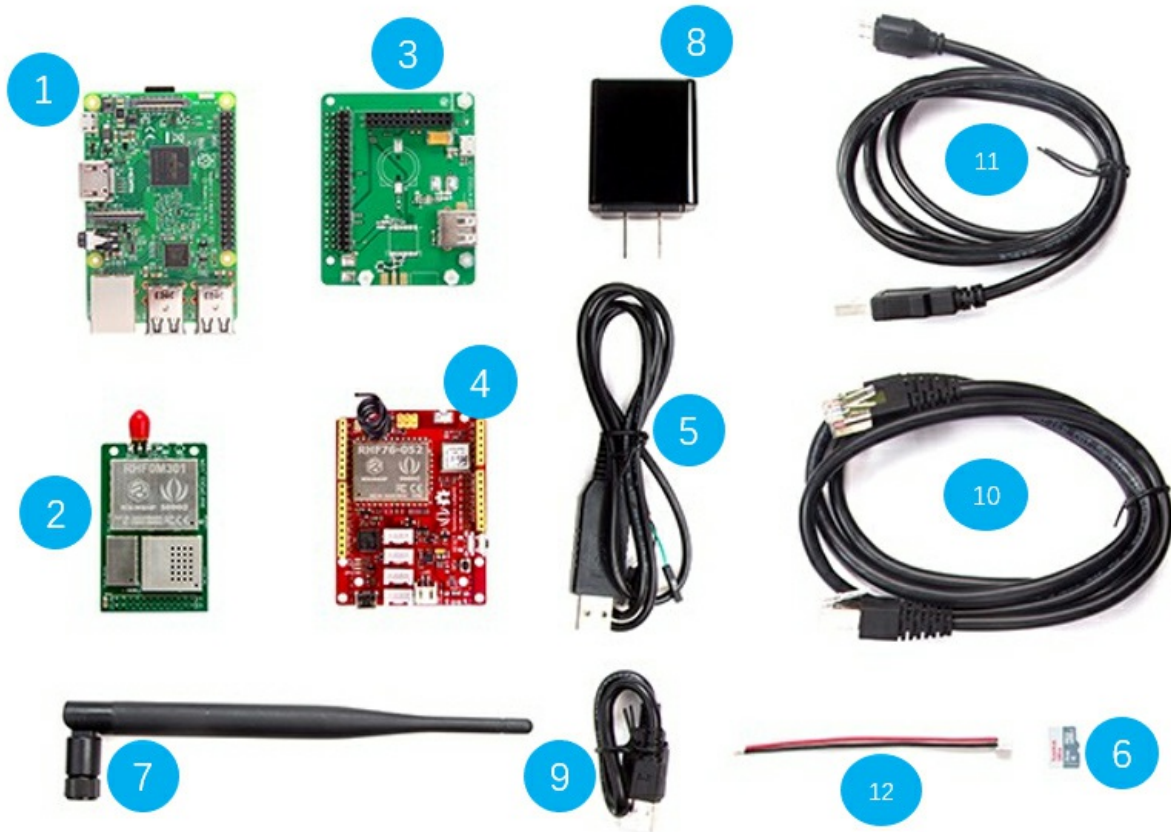

Partlist

Parts number	Parts name	Quantity
1	Raspberry Pi 3	1 PCS
2	Gateway module RHF0M301-868	1 PCS
3	PRI 2 Bridge RHF4T002	1 PCS
4	Seeeduino LoRaWAN with GPS (RHF76-052AM)	1 PCS
5	USB to UART Adapter	1 PCS
6	upgrade to 16GB Micro SD Card – Class 10	1 PCS
7	0dBi Rubber Duck Antenna	1 PCS
8	5V/2.1A American Standard Adapter with Micro USB Connector	1 PCS
9	Micro USB Cable 20cm	1 PCS
10	Micro USB Cable 100cm	1 PCS

11	RJ45 Ethernet Cable 200cm	1 PCS
12	JST2.0 Cable 10cm	1 PCS

Application Ideas

- Internet of Things
- Smart House
- Security
- Smart Grid
- Intelligent Farm
- Intelligent Park

Getting Started

Hardware

Interfaces overview

Since there are many interfaces here, it is necessary to know the capabilities of these interfaces. Please refer to the following figure for details.



- **1 Micro-USB Input:**
The whole system use this Micro-USB interface for power supply.
- **2 USB HOST Connector:**
Output power to supply for Raspberry Pi
- **3 Raspberry Pi power input:** Input power for Raspberry.

- **4** **HDMI**: HD digital video output interface.
- **5** **Headphone jack**: 3.5mm Headphone jack
- **6** **Ethernet interface**: You can use the Ethernet interface to connect this system to the Internet. Or you can use Wifi after you configured the wireless network.

Hardware connection

- Step 1. Plug Gateway module RHF0M301–868 into PRI 2 Bridge RHF4T002.
- Step 2. Plug PRI 2 Bridge RHF4T002 into Raspberry Pi 3.
- Step 3. Connect **2** and **3** via the 20cm Micro-USB cable.
- Step 4. Connect the **USB to UART Adapter** to the GPIO of **Raspberry Pi 3**. Please connect them as the picture shown below.

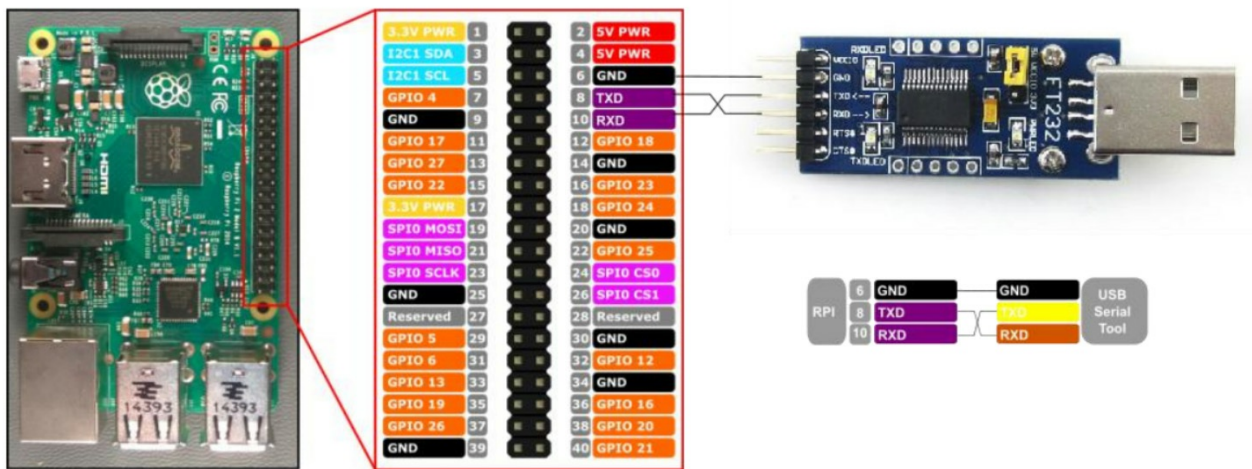

- Step 5. Plug the **USB to UART Adapter** into your PC.
- Step 6. Connect **1** with 5V/2.1A Standard Adapter via 100cm Micro-USB cable.

When you finished all the steps, the whole system should be like the picture below.



Software

Software Tool

In the following guide, below tools will be needed, please install it to your computer.

- **Arduino**, portable serial tool, used to open the serial port of Seeeduino LoRaWAN with GPS (RHF76-052AM) and send AT commands to it.
- **PuTTY**, terminal tool include both serial and SSH terminal, used to control Raspberry Pi.
- Internet browser, used to access RHF2S001 integrated LoRaWAN server (It is recommended to use Chrome or Firefox).

Note

You may have your other favorite serial tools, of course you can use them. However if you are not sure about your tools. Please use the ones we recommend.

Connect To Local Server

Step 1. Power up and connect to putty

- First, make sure the serial tool and RPi (RHF4T002 Adapter) are connected correctly.
- Plug FT232 tool to PC (If COM port is not recognized correctly, please refer below driver installation chapter)
- Open **Device Manager** of your PC to get the right COM port. Like COM15 for example. Configure ExtraPuTTY according to below picture (Speed 115200, others use defaults), click **Open**. As the gateway is still not opened, so there is nothing in the terminal.

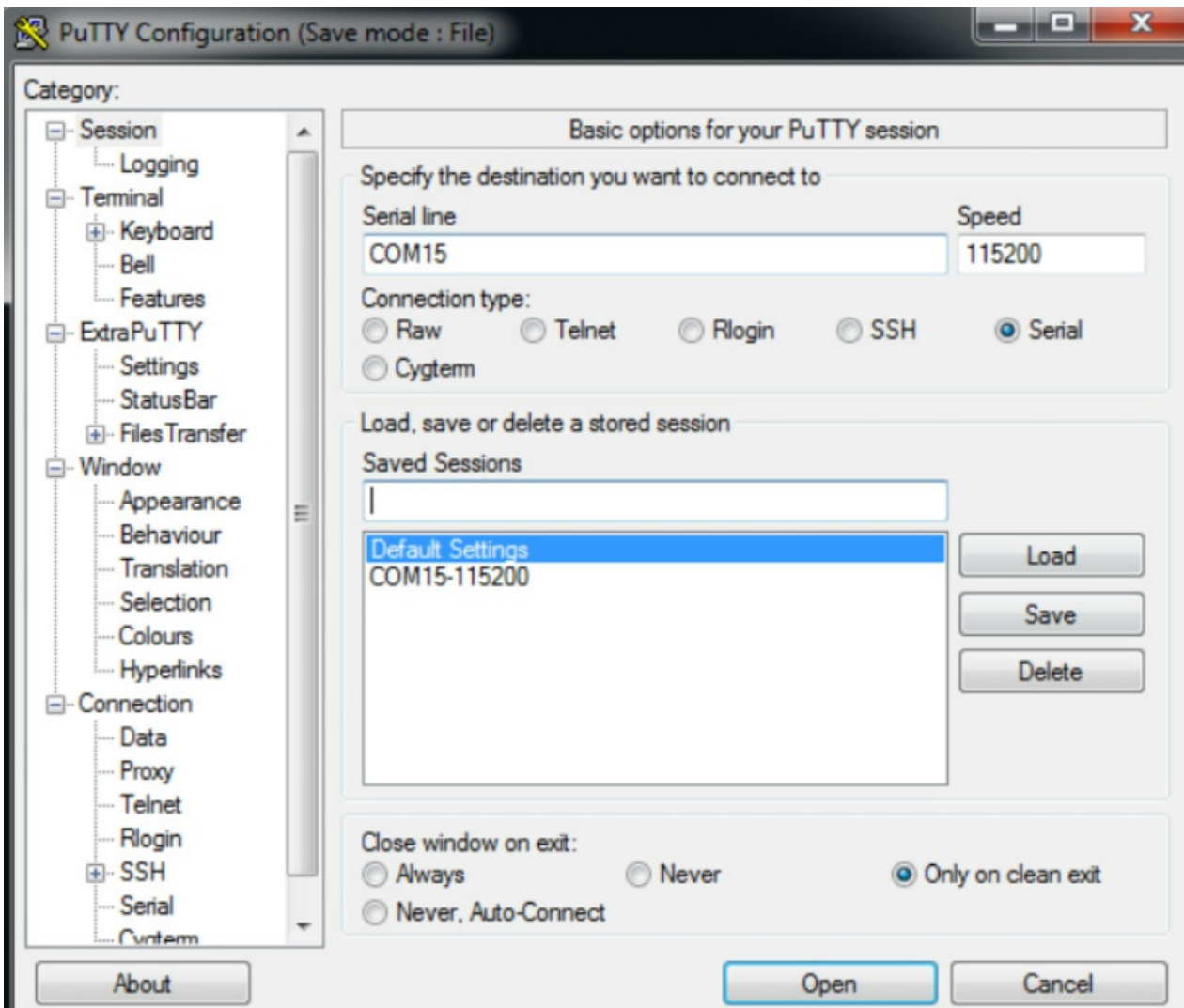

d) Power the gateway up. Booting log will be showed in the PuTTY terminal, in the end it will prompt you to input your log in name. Please note it takes 1 or 2 minutes to get the prompt information.

```
COM15 - PuTTY
Session Special Command Window Logging Files Transfer Hangup ?
[ 3.598002] systemd[1]: Mounting Debug File System...
[ 3.611311] systemd[1]: Starting Slices.
[ 3.620124] systemd[1]: Reached target Slices.
[ 3.632685] systemd[1]: Mounted POSIX Message Queue File System.
[ 3.644789] systemd[1]: Mounted Debug File System.
[ 3.656527] systemd[1]: Started Increase datagram queue length.
[ 3.688214] systemd[1]: Started Restore / save the current clock.
[ 3.700754] systemd[1]: Started Create list of required static device nodes f
[ 3.720809] systemd[1]: Started Load Kernel Modules.
[ 3.733683] systemd[1]: Started File System Check on Root Device.
[ 3.758855] systemd[1]: Time has been changed
[ 3.792364] systemd[1]: Started udev Coldplug all Devices.
[ 3.967216] systemd[1]: Mounted FUSE Control File System.
[ 3.974639] systemd[1]: Starting Apply Kernel Variables...
[ 3.988611] systemd[1]: Mounting Configuration File System...
[ 4.003398] systemd[1]: Starting Create Static Device Nodes in /dev...

Raspbian GNU/Linux 8 rhf2s001 ttyAMA0

rhf2s001 login: █

00:04:53 Connected SERIAL/115200 8 N 1
```

e) Please use RHF2S001 default user name and password to log in. (Username: rxhf, Password: risinghf). Note, when input the password, there is no any echo

f) Connect RHF2S001 with router through ethernet cable

g) Run `ifconfig` to check the ip address and mac address.

```
COM21 - PuTTY
Linux rhf2s001 4.4.21-v7+ #911 SMP Thu Sep 15 14:22:38 BST 2016 armv7l

The programs included with the Debian GNU/Linux system are free software;
the exact distribution terms for each program are described in the
individual files in /usr/share/doc/*/copyright.

Debian GNU/Linux comes with ABSOLUTELY NO WARRANTY, to the extent
permitted by applicable law.
rxhf@rhf2s001:~$ ifconfig
eth0      Link encap:Ethernet  HWaddr b8:27:eb:
          inet addr:192.168.199.225  Bcast:192.168.199.255  Mask:255.255.255.0
          inet6 addr: fe80::11a6:6b9f:blf8:b465/64 Scope:Link
          UP BROADCAST RUNNING MULTICAST  MTU:1500  Metric:1
          RX packets:449 errors:0 dropped:0 overruns:0 frame:0
          TX packets:89 errors:0 dropped:0 overruns:0 carrier:0
          collisions:0 txqueuelen:1000
          RX bytes:41222 (40.2 KiB)  TX bytes:10920 (10.6 KiB)

lo        Link encap:Local Loopback
          inet addr:127.0.0.1  Mask:255.0.0.0
          inet6 addr: ::1/128 Scope:Host
          UP LOOPBACK RUNNING  MTU:65536  Metric:1
          RX packets:5863 errors:0 dropped:0 overruns:0 frame:0
          TX packets:5863 errors:0 dropped:0 overruns:0 carrier:0
```

IP is in the blue square, MAC address is in orange square (Format: b8:27:eb:xx:xx:xx)

Note

After you get the IP, it is recommended to login RHF2So01 again through SSH. Because SSH is faster (Ethernet than UART) and

stable. We normally use serial tool to get the IP. Reopen PuTTY, use the SSH module to connect again.

To login through SSH, you need to fill in the Hostname with the IP address you've just got. And use port 22, choose the SSH connection type. Just leave the other options by default. Then simply click **Open**.

□

Step 2. Expand SD Card File System

By default, the image enables only 2GB for Raspbian System, it is recommended to expand to use the whole SD card (8GB or 16GB). Or the SD card will be full soon.

Run below command in the PuTTY terminal to start raspi-config,

```
sudo raspi-config
```

Choose "Expand Filesystem", when finished reboot to make it effect. Run below command in the PuTTY terminal to know the SD card capacity and usage.

```
df -h
```

Please refer to Raspberry Pi raspi-config tool instruction for details. Click [here](#) see more.

Step 3. Use RHF2S001 integrated LoRaWAN server

a) Connect Gateway with internal server

Run below commands in the PuTTY terminal, and check the status:

```
sudo systemctl status pktfwd
```

If pktfwd service is not active, run below command to start it:

```
sudo systemctl enable pktfwd
sudo systemctl restart pktfwd
```

b) Frequency Plan

Frequency Plan for EU868

	EU868	Uplink DR
CH0	867.1	DR0 ~ DR5
CH1	867.3	DR0 ~ DR5
CH2	867.5	DR0 ~ DR5
CH3	867.7	DR0 ~ DR5
CH4	867.9	DR0 ~ DR5
CH5	868.1	DR0 ~ DR5
CH6	868.3	DR0 ~ DR5
CH7	868.5	DR0 ~ DR5

Frequency Plan for US915 HYBRID

	US915	Uplink DR
CH0	902.3	DR0 ~ DR3
CH1	902.5	DR0 ~ DR3

CH2	902.7	DR0 ~ DR3
CH3	902.9	DR0 ~ DR3
CH4	903.1	DR0 ~ DR3
CH5	903.3	DR0 ~ DR3
CH6	903.5	DR0 ~ DR3
CH7	903.7	DR0 ~ DR3
CH64	903.0	DR4

c) RHF76-052AM Settings

Now let's configure the Seeeduino LoRaWAN with GPS (RHF76-052AM).

- Firstly, you need to connect Seeeduino LoRaWAN GPS to your PC.
- Secondly, open the [Arduino IDE](#), and copy the code below into a new sketch.

```
void setup()
{
  Serial1.begin(9600);
  SerialUSB.begin(115200);
}

void loop()
{
  while(Serial1.available())
  {
    SerialUSB.write(Serial1.read());
  }
  while(SerialUSB.available())
  {
    Serial1.write(SerialUSB.read());
  }
}
```

- Then choose the right serial port of Seeeduino Lora GPS, and choose the board **Tool->Board->Seeeduino_LoRAWAN**. After that you can click the upload button. If you can not find Seeeduino_LoRAWAN in the board list or do not know how to update the code, please click [here](#) for more information.

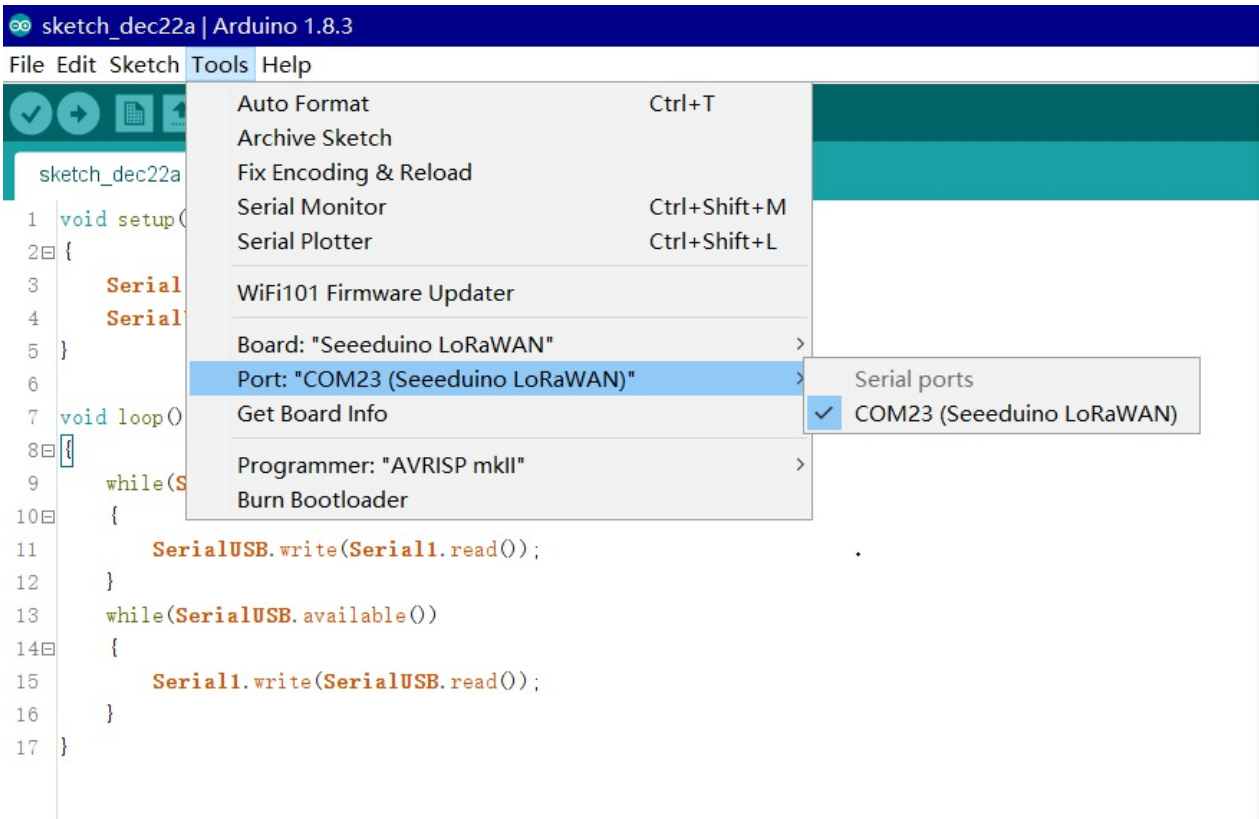

- Now please open the serial monitor in the upper right corner (or you can press Ctrl+Shift+M at the same time). Choose **New line** (This option will add "\r\n" at the end of each command.), set the baud rate 9600. Then tap the commands below and press **send**.

For EU868

```

AT+FDEFAULT=RISINGHF
AT+DR=EU868

```

For US915

```

AT+FDEFAULT=RISINGHF
AT+DR=US915HYBRID
AT+RXWIN2=923.3,DR8

```

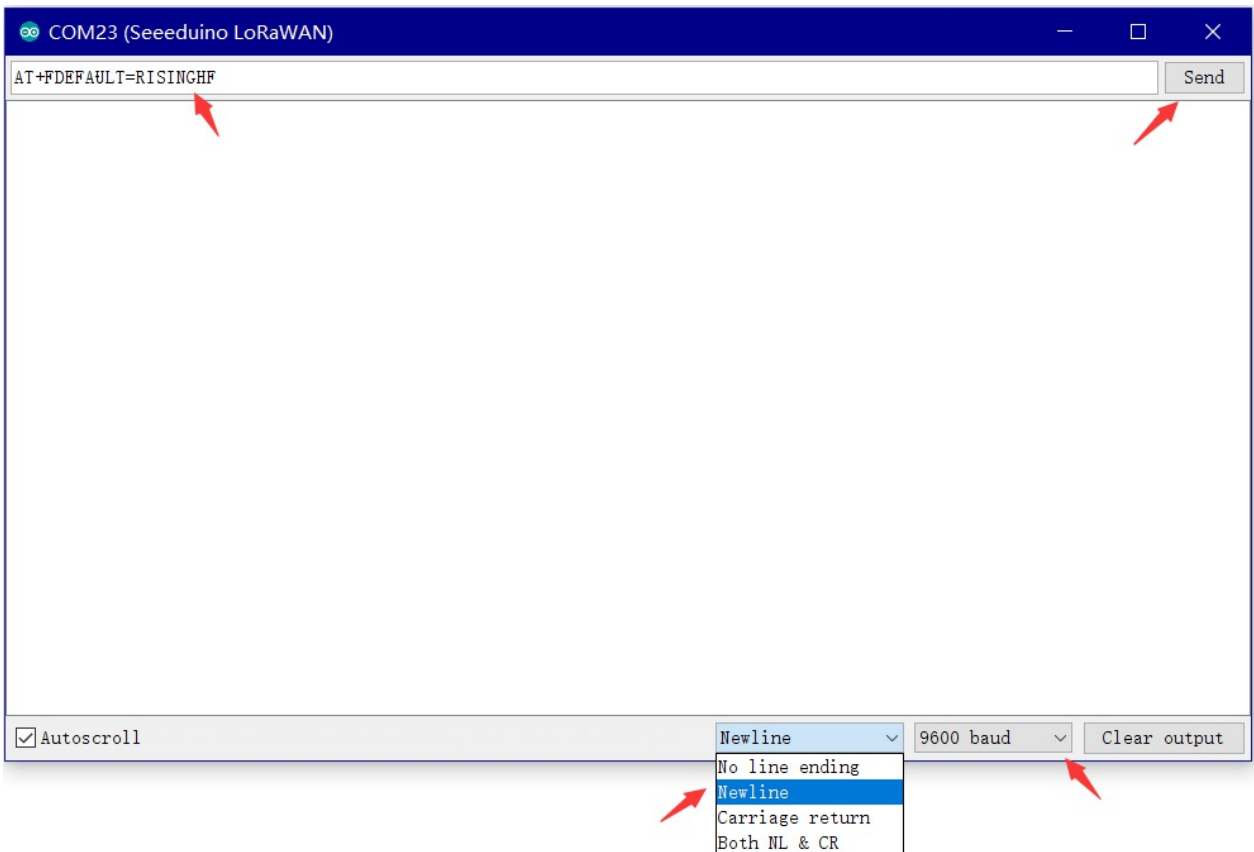

Caution

After you plug Seeeduino LoRaWAN with GPS into your computer, you may find two serial Ports. One is for raspberry with putty, one is for Seeeduino LoRaWAN GPS with SSCOM, please choose the right one.

d) Access Internal Server Console

Fill your browser with the IP address (IP of your gateway), it will jump to the website below.

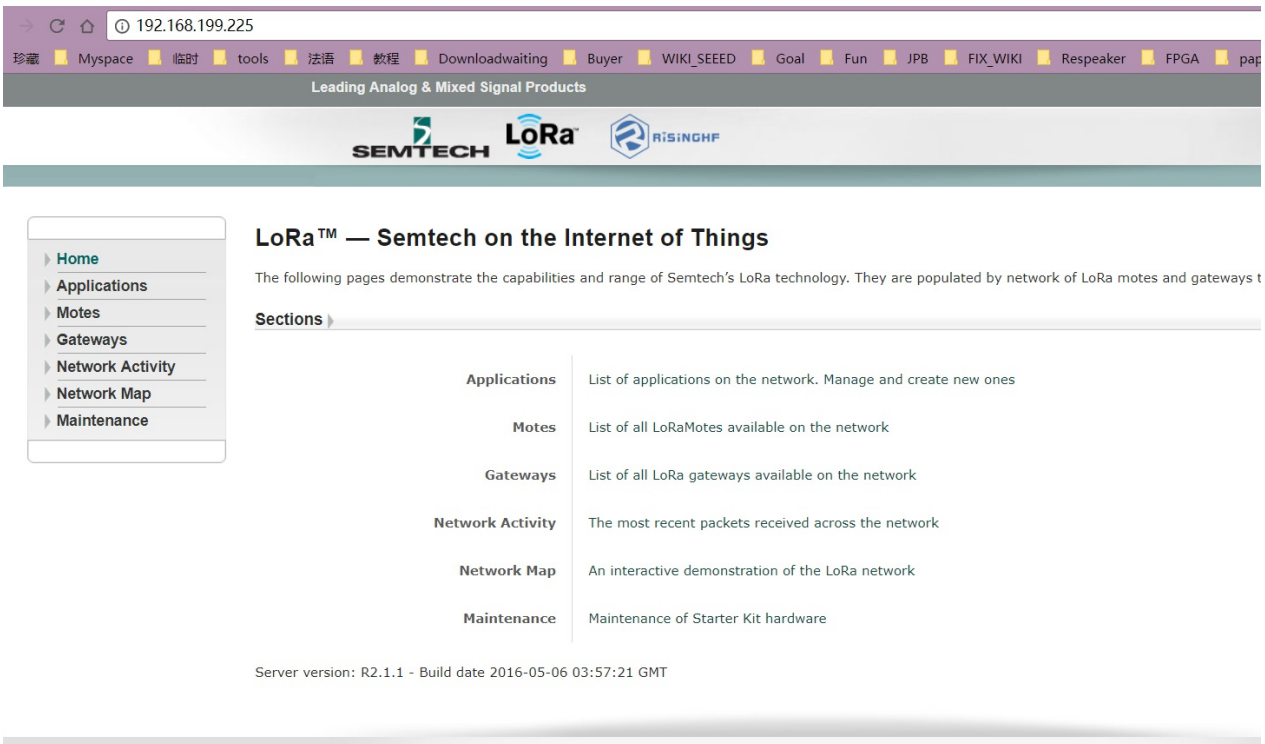

Step 4. Use Seeeduino LoRaWAN GPS(RHF76-052AM) access LoRaWAN server

There are two modes, in this wiki we only talk about the ABP Mode (This Mode is free for anyone), for more information about OTAA Mode (This model is commercial, you need to pay for it), you can click [here](#).

a) Find the "Application" button in the upper right corner of the website above, click it and you will see a new page.

b) Now you need **APPEui, DevAddr, DevEui** of Seeeduino LoRaWAN to add a new application.

In order to get the ID information of Seeeduino LoRaWAN, you need to tap the command below in the serial monitor of Arduino IDE. Click **Send**, you will get the ID then.

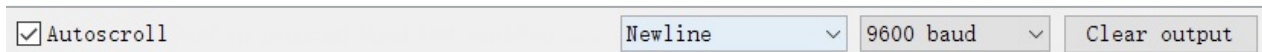

c) Fill in the blank with the ID info. you just get. You can fill in the name and owner as your wish (here we use Seeed and my nick name:), use the APPEui you've just got. Then click **Add** button.

Home \ Applications

- Home
- Applications**
- Motes
- Gateways
- Network Activity
- Network Map
- Maintenance

Applications

Below is a list of LoRa applications on the network. Use the fields at the top to set up a new one on the server.

Name	Owner	EUI (AppEUI)	Configured	Notes
New: <input type="text" value="Seed"/>	<input type="text" value="Jelly"/>	<input type="text" value="52:69:73:69:6E:67:48:46"/>	<input type="button" value="Add"/>	
null	[Unknown]	FF-FF-FF-FF-FF-FF-FE	<input type="button" value="Delete"/>	0

Then you will jump into the configure page. In this page, we choose Personalised Motes. Fill in the **DevEUI** and **DevAddr** with ID info. of your Seeeduino LoRaWAN GPS. And set the **NWKSKEY** and **APPSKEY** by default. You can refer to the picture below.

- DevEui: Seeeduino LoRaWAN GPS get through AT+ID command
- DevAddr: Seeeduino LoRaWAN GPS get through AT+ID command
- NWKSKEY: Default value 2B7E151628AED2A6ABF7158809CF4F3C
- APPSKEY: Default value 2B7E151628AED2A6ABF7158809CF4F3C

Motes

Seed Motes

Below are the motes configured for this application. A new one may be commissioned using over-the-air protocol or personalisation.

Text Size

Over-the-Air Motes

Motes ordinarily join the network by negotiating with the server using an application key. Enter this key below to prepare the server.

Mote (DevEUI)	Application Key (AppKey)
New: <input type="text"/>	<input type="text"/>

Personalised Motes

Personalised motes are configured with the network address, application session key and network session key already present, so they are ready to communicate on the network. Enter these same details below to prepare the server.

Mote (DevEUI)	Network Address (DevAddr)	Application Session Key (AppSKey)	Network Session Key (NwkSKey)
New: <input type="text" value="47:99:B2:69:00:34:00:5C"/>	<input type="text" value="00:FE:88:B2"/>	<input type="text" value="2B7E151628AED2A6ABF7158809CF4F3C"/>	<input type="text" value="2B7E151628AED2A6ABF7158809CF4F3C"/>

d) To test whether you add the device successfully, you can use the serial monitor of Arduino IDE tap the command below.

```
at+mode=1wabp

AT+CMSSGHX="0a 0b 0c 0d 0e"
```

It should like something below.

COM23 (Seeeduino LoRaWAN)

Send

```

+MODE: LWABP
+MSGHEX: Start
+MSGHEX: TX "0A 0B 0C 0D 0E "
+MSGHEX: Wait ACK
+MSGHEX: ACK Received
+MSGHEX: RXWIN1, RSSI -84, SNR 8.3
+MSGHEX: Done

```

Autoscroll Newline 9600 baud Clear output

Then turn to the website, click **Application->Seed**(the name of the Application you just added)->**View application data**, you will see the data you've just sent from the Seeeduino_LoRAWAN. congratulations! Job done!



Home \ Applications \ Seed \ Data

- ▶ Home
- ▶ **Applications**
- ▶ Notes
- ▶ Gateways
- ▶ Network Activity
- ▶ Network Map
- ▶ Maintenance

Seed Data

Below is data received for this application.

▶ Download Data

Mote (DevEUI)	Port	Time	Sequence #	Application Data
47-86-C5-8B-00-2A-00-2F	8	2017-12-23 08:04:52	1	0a 0b 0c 0d 0e
47-86-C5-8B-00-2A-00-2F	8	2017-12-23 07:58:21	1	0a 0b 0c 0d 0e

Connect To Lorient Server

Step.1 Lorient Server Gateway Registration

a) New user need register an account first, click [registration address](#) . Fill in UserName, Passw ord and email address to register, after registration an email w ill be sent to you, please follow the instruction in the email to activate.

b) After successful activation, click [here](#) to log in. Default tier is "Community Network", it supports 1 Gateway (RHF2S001) and 10 nodes.

c) Enter **Dashboard -> Gateway**, click **Add Gateway** start to add Gateway.

d) Select **Raspberry Pi 3**

e) Set as below :

- Radio front-end -> RHF2S001 868/915 MHz(SX1257)
- BUS -> SPI

f) Fill in the MAC address of your RHF2S001, should be in format of b8:27:eb:xx:xx:xx. And also input Gateway Location information.

g) Click "Register Raspberry Pi gateway" to finish the registration.



The screenshot shows the LORIO T web interface. The top navigation bar includes 'Dashboard > Gateways' and 'Community Network'. The left sidebar has a 'back to dashboard' link, a 'Gateways' section with a Wi-Fi icon, a 'Map' section with a map icon, and an 'Add gateway' button. Below the sidebar, there is a 'My gateways' section. The main content area is titled 'Raspberry Pi 3' and features a dropdown menu for 'Radio front-end' set to 'RHF2S001 868/915 MHz (SX1257)' and another dropdown for 'Bus' set to 'SPI'. Below these, there is a text box with instructions: 'Raspberry Pi can be turned into a universal, inexpensive base for a LoRa or real deployment. Several USB and SPI attached concentrators are supported.' A link 'Choose a different base platform' is visible. The next section is titled 'MAC address of eth0 interface' and contains the text: 'The MAC Address of the Ethernet port can be queried by running ifconfig eth0 | grep HWaddr command from your device's console. A sample output will be similar to eth0 Link encap:Ethernet HWaddr AB:CD:EF:12:34:56 Copy and past the highlighted part (six octets separated by colons) from the output of your device console'. At the bottom, there is a form for 'eth0 MAC address' with the value 'b8:27:et' entered.

h) Click the registered gateway to enter configuration page, switch "Frequency Plan" manually, your plan here is decided by the type of your RHF2S001 type, available plan are CN470, CN473, CN434, CN780, EU868, after selected please refresh the page to get the exact channel. In this wiki we choose **EU868**.

i) Run the command in the putty terminal:

```
cd /home/rxhf/loriot/1.0.2
sudo systemctl stop pktfwd
sudo gwrst
wget https://cn1.loriot.io/home/gwsw/loriot-risinghf-rhf2s008-rhf1257-SPI-0-latest.bin -O loriot-gw.bin
chmod +x loriot-gw.bin
./loriot-gw.bin -f -s cn1.loriot.io
```

j) Finish gateway registration. You will see the gateway is Connected now. Next is to register node.

LORIoT Dashboard > Gateways

← back to dashboard

Gateways

Map

Gateway capacity exhausted

My gateways

B8:27:EB [redacted]

B8-27-EB- [redacted]

Gateway / Raspberry Pi 3 B8:27:EB: [redacted]

Uptime this month

Gateway has been offline this month

Actions

Data tap Tap into data stream

Ping Ping gateway

Restart Restart gateway

Status

Connected Connected

Version 2.6.828-JKS-CN-7

Latency 72 ms

a few seconds ago

Last keep-alive 23rd Dec 2017,

Gateway information



Machine armv7l

Name rhf2s001

Kernel 4.4.21-v7+

Version #911 SMP Thu Sep 15 14:22:38 BST 2016

EUI

Title

Base and model

Step 2. Lorient Server Connect Node device

a) Get the available gateway channels

Current gateway channels could be got from **Dashboard -> Gateway -> Your Gateway** , you can see the available channels as the picture below .

Channel allocation

Radio	Center frequency [MHz]	Bandwidth [kHz]	Modulation
1	868.100	125	MultiSF
1	868.300	125	MultiSF
1	868.500	125	MultiSF
0	867.100	125	MultiSF
0	867.300	125	MultiSF
0	867.500	125	MultiSF
0	867.700	125	MultiSF
0	867.900	125	MultiSF
1	868.300	250	SF7
1	868.800	125	FSK

b) Seeeduno LoRAWAN GPS(RHF3M076) Configuration

Open the serial monitor of Arduino IDE, tap the command below .

```
at+ch
```

To confirm the default channel of your Seeeduino_LoRAWAN GPS, you will get 3 channels. If there is no available channel, you can change the channels of Seeeduino_LoRAWAN by the command below.

```
at+ch=0,868.1
at+ch=1,868.3
at+ch=2,868.5
```

Then you can use **at+ch** again to check.

c) Add Seeeduino_LoRAWAN GPS as an ABP Node

Log in Lorient server, Click **Dash Board->Applications->SimpleApp**. Click **Import ABP**, input below items:

- DevAddr: Seeeduino_LoRAWAN GPS get through "AT+ID" command (Note: Lorient doesn't support colon connector, need remove manually)
- FCntUp: Set to 1
- FCntDn: Set to 1
- NWKSEKEY: Default value 2B7E151628AED2A6ABF7158809CF4F3C
- APPSKEY: Default value 2B7E151628AED2A6ABF7158809CF4F3C
- EUI: DEVEUI, Seeeduino_LoRAWAN GPS get through "AT+ID" command

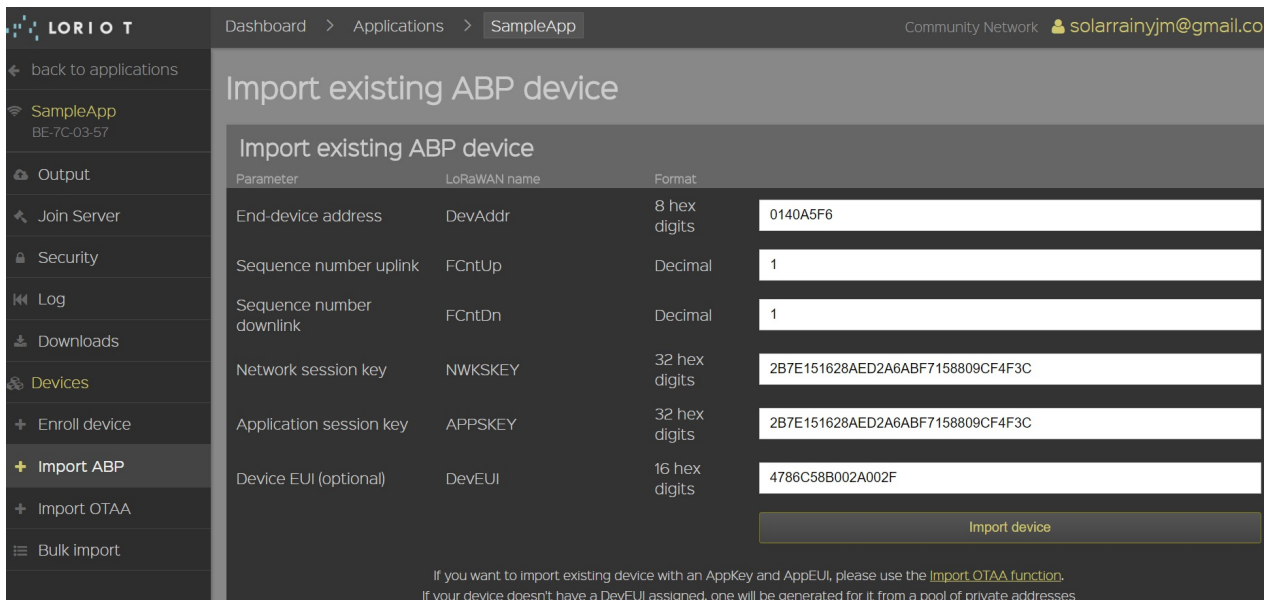

Dashboard > Applications > SampleApp Community Network solarainyjm@gmail.co

Import existing ABP device

Parameter	LoRaWAN name	Format	
End-device address	DevAddr	8 hex digits	0140A5F6
Sequence number uplink	FCntUp	Decimal	1
Sequence number downlink	FCntDn	Decimal	1
Network session key	NWKSKEY	32 hex digits	2B7E151628AED2A6ABF7158809CF4F3C
Application session key	APPSKEY	32 hex digits	2B7E151628AED2A6ABF7158809CF4F3C
Device EUI (optional)	DevEUI	16 hex digits	4786C58B002A002F

[Import device](#)

If you want to import existing device with an AppKey and AppEUI, please use the [Import OTAA function](#).
If your device doesn't have a DevEUI assigned, one will be generated for it from a pool of private addresses

Click **Import Device** button to finish the device import.

Now choose **Dashboard -> Applications -> SampleApp**, you will see the new ABP Node you've just added.

Dashboard > Applications > SampleApp

Community Network solarainyjm@gmail

back to applications

SampleApp BE-7C-03-57

Output

Join Server

Security

Log

Downloads

Devices

Enroll device

Import ABP

Import OTAA

Bulk import

Devices

Generate new device

Enroll new device

Import existing OTAA

Import existing ABP

Devices in this application [3]

RSSI	SNR	DSNR	SF	BAT	ADR	Class	Application EUI	Device EUI	Devaddr	Last data	SeqNo	SeqNo
-4	10.8	4	12	NA	ADR	A	no AppEUI	47-86-C5-88-00-89-11-90	00-A0-A4-A0	a month ago	2	4
-26	10.8	-5	12	NA	ADR	A	no AppEUI	47-86-C5-88-00-89-11-AA	00-A0-A4-55	a month ago	3	4
				NA	ADR	A	no AppEUI	47-86-C5-88-00-2A-00-2F	01-40-A5-F6	never	1	1

d) Send data from Seeeduino_LoRAWAN

Back to serial monitor of Arduino IDE, send command:

```
AT+CMSSGHEX="0a 0b 0c 0d 0e"
```

Then go to **Dashboard -> Applications -> SampleApp -> Device**, click the Node Device EUI or DevAddr, you will find the data you've just sent here.

Bandwidth 125 kHz

Gateway B827EBFFFF810859

Gateways in range

RSSI	SNR	Seen
-85	8.5	2 minutes ago

Last data (10 latest records)

SeqNo	Time	Port	Data
2	2 minutes	8	0a 0b 0c 0d 0e

DEVAddr F6A54...

NOTE: Use big endian re

See the [device guide](#)

LoRaWAN AES

AppKey

Application Key (Device K

NwkSKey

Network Session Key

FAQs

Please click [here](#) to see all LoRa/LoRaWAN Gateway Kit FAQs.

Tech support

Please do not hesitate to contact techsupport@seeed.cc if you require further information.

Resources

- **[PDF]** [Download Wiki PDF](#)
- **[User Manual]** [User Manual](#).
- **[More Reading]** [Wiki of Seeeduino LoRaWAN](#)
- **[More Reading]** [RisingHF Website](#)