

SPECIFICATIONS:

ELECTRICAL LIFE: 50,000 make-and-break cycles at full load.

CONTACT RESISTANCE: 10mΩ max. initial @ 2-4VDC. 100mA for both silver and gold plated contacts.

INSULATION RESISTANCE: 1,000MΩ min.

DIELECTRIC STRENGTHS: 1,500V RMS @ sea level.

OPERATING TEMPERATURE: -30°C to +85°C.

MATERIALS:

CASE: Diallyl phthalate(DAP)(UL 94V-0).

ROCKERS: Nylon 6/6.

BUSHING: Zinc, nickel plated.

HOUSING: Stainless steel.

FRONT/REAR MOUNTING: Stainless steel.

SWITCH SUPPORT: Brass, tin plated.

TERMINAL SEAL: Epoxy.

Art. Nr.

RND 210-00505

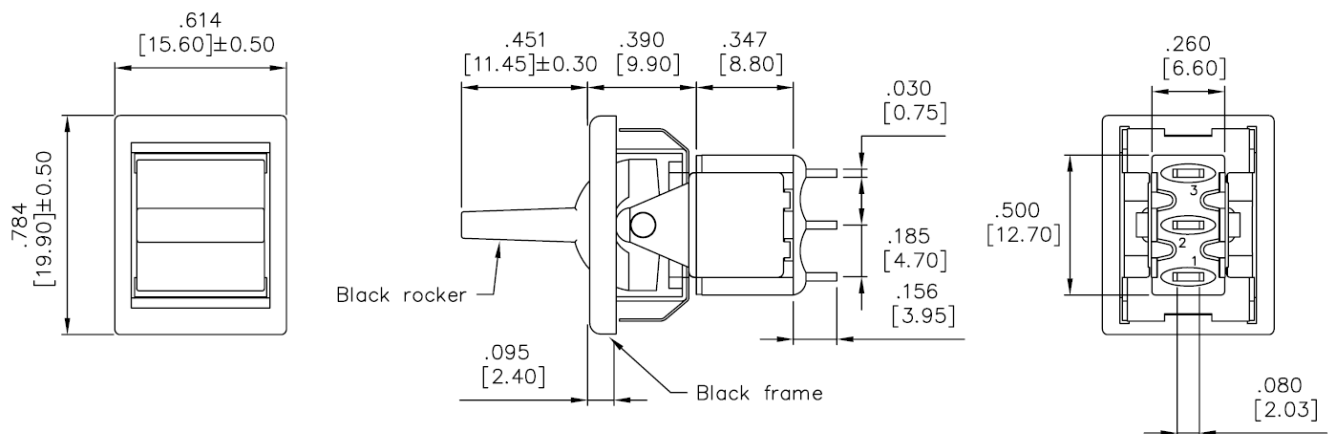

PANEL MOUNTING

