

New

3-colour display Digital Flow Switch for Water



RoHS

IP65

3-colour / 2-screen display

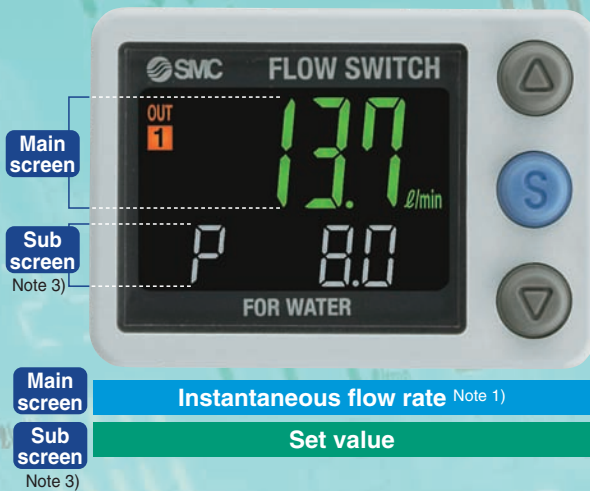

Instantaneous flow rate (Note 1)			
Accumulated value	Peak/Bottom value	Line name	Fluid temperature (Note 2)

Note 1) Main screen shows the instantaneous flow rate only.
 Note 2) Fluid temperature can be displayed only when the digital flow switch with a temperature sensor is selected.
 Note 3) Sub screen can be turned off.

Integrated flow adjustment valve and temperature sensor

New Flow adjustment valve



Additional remote type

New



Additional PVC piping type

New



- Applicable fluid: Deionized water, chemical, etc.
- Flow rate range: 10 to 100 l/min
- Integrated type and remote type added to series.

Series PF3W



CAT.EUS100-80B-UK

40% smaller than existing product

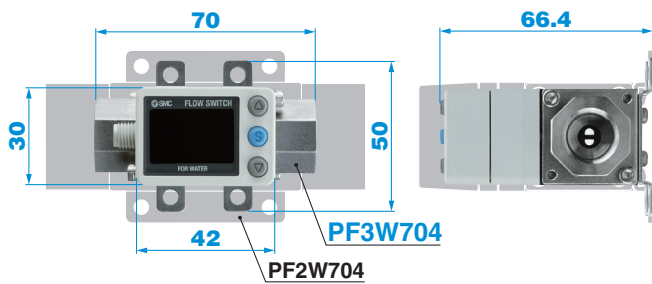

Reducing piping space

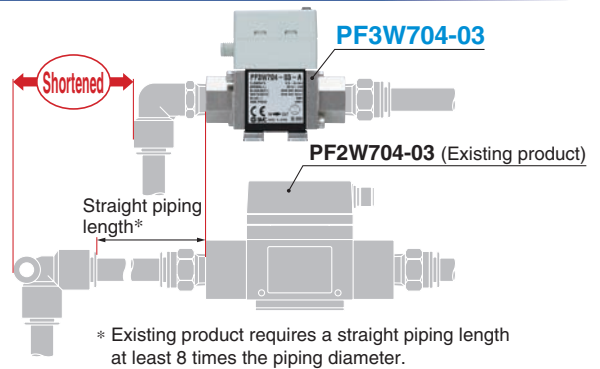

Temperature sensor

Display range: **-10 to 110°C**
(Temperature sensor alone)

Minimum setting unit: **1°C**

Analogue output:
Current output/Voltage output



Temperature display

Flow adjust-ment valve

Space saving and reduced piping labour



Temperature sensor

Fluid temperature: 0 to 90°C

Ethylene glycol aqueous solution can be used

Example) Flow control of the circulating fluid in a chiller

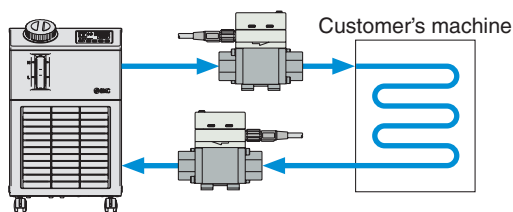

Rotatable display

Display can be rotated in increments of 45° to suit the installation conditions. Easy operation, improved visibility.

Counterclockwise **90°**
Clockwise **225°**

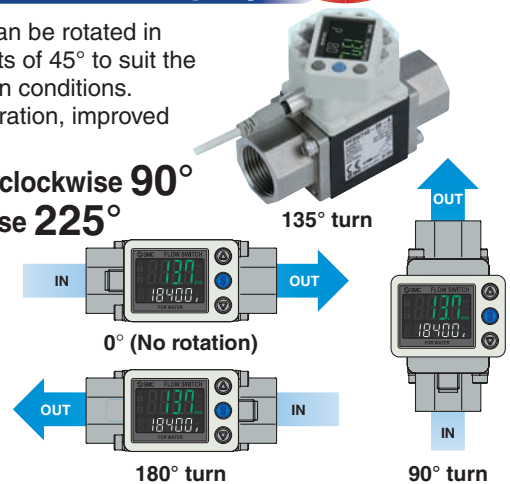

Non-grease

Mounting

Bracket mounting

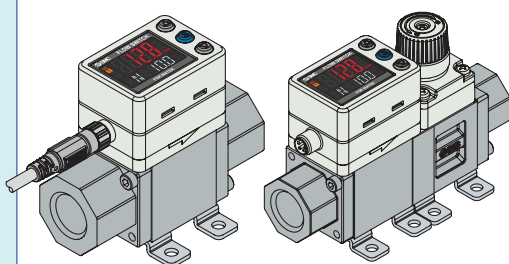

Direct mounting

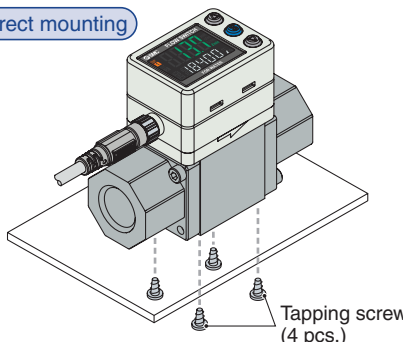



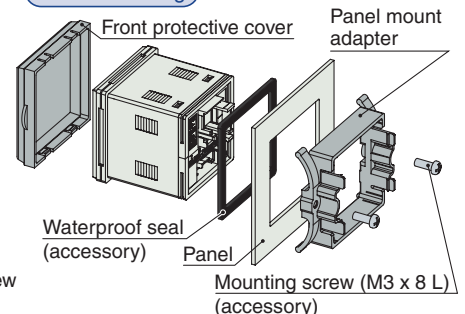

Panel mounting

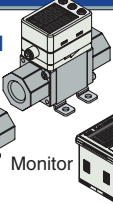

INDEX

Measured flow rate **100 l/min** added

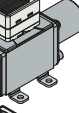
Variations

Type	Applicable fluid	Rated flow range (l/min)	Flow adjustment valve/Temperature sensor				Port size Rc, NPT, G
			None	Flow adjustment valve	Temperature sensor	Flow adjustment valve + Temperature sensor	
Integrated  Remote sensor  	Water	0.5 to 4	●	●	●	●	3/8
	Ethylene glycol aqueous solution	2 to 16	●	●	●	●	3/8, 1/2
		5 to 40	●	●	●	●	1/2, 3/4
		10 to 100	●	—	●	—	3/4, 1
PVC piping type Integrated  Remote sensor  	Deionized water	10 to 100	●	—	—	—	25A
Chemical							

3-Colour Display Digital Flow Switch for Water PF3W

How to Order 1

Specifications (Integrated Display) 2

Specifications (Remote Sensor Unit) 3

Flow-rate Characteristics (Pressure Loss) 4

Example of Internal Circuit and Wiring 5, 6

Made to Order 6

Description/Wetted Parts Construction 7

Dimensions 8

3-Colour Display Digital Flow Switch for Water PF3W

3-Colour Display Digital Flow Switch for PVC Piping PF3W

How to Order 11

Specifications (Integrated Display) 12

Specifications (Remote Sensor Unit) 13

Description/Wetted Parts Constructions 14

Dimensions 15

3-Colour Display Digital Flow Switch for PVC Piping PF3W

3-Colour Display Digital Flow Monitor for Water PF3W3

How to Order 16

Specifications 17

Example of Internal Circuit and Wiring 18, 19

Description (Remote Monitor Unit) 19

Dimensions 20

3-Colour Display Digital Flow Monitor for Water PF3W3

Function Details 21

Function Details

3-colour display Digital flow monitor can copy to up to **10** switches simultaneously.

The settings of the master sensor (source of copy) can be copied to the slave sensors.

- Reducing setting labour
- Minimising risk of mistakes in setting

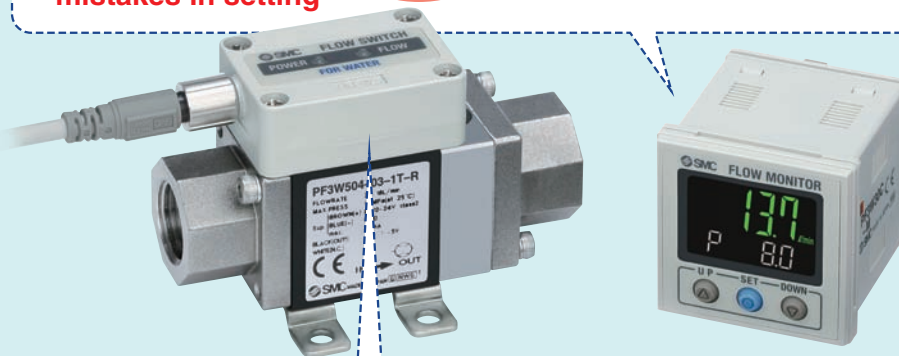
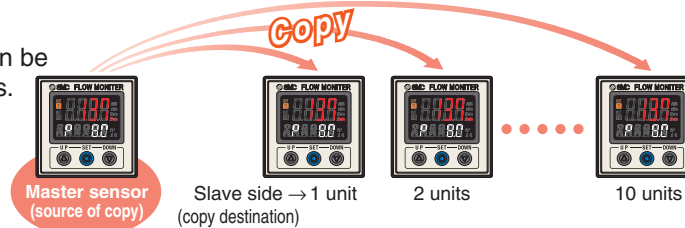

Indicator

Visually check status of sensor via indicator.



Flow rate: High		Blinking green/Fast
Flow rate: Low		Blinking green/Slow
Rated flow or less		OFF
Rated flow or more		Red ON

Reducing wiring labour by connector

e-con connector
No tools and peeling required

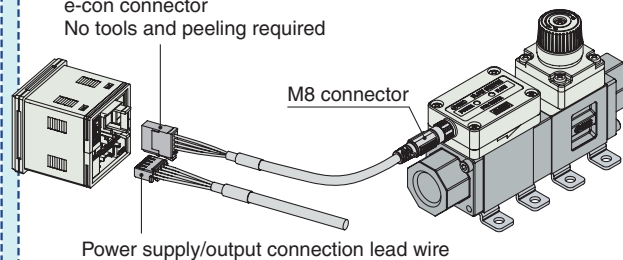

PVC piping type



Wetted Parts

Pipe	CPVC (Heat resistant PVC)
Body	PPS
Seal	FKM

3-colour display



RoHS

Digital Flow Switch for Water

Series PF3W

How to Order

Remote sensor unit Output specification/Temperature sensor

Symbol	OUT1	OUT2	Temperature sensor
	Flow rate	Temperature	
1	Analogue 1 to 5 V	—	None
2	Analogue 4 to 20 mA	—	
1T	Analogue 1 to 5 V	Analogue 1 to 5 V	

Symbol	Instantaneous flow rate	Accumulated flow	Temperature
—	ℓ/min	ℓ	°C
G	gal/min	gal	°C
F	gal/min	gal	°F
J	ℓ/min	ℓ	°F

Note) G, F, J: Made to Order
 Reference: 1 [ℓ/min] ↔ 0.2642 [gal/min]
 1 [gal/min] ↔ 3.785 [ℓ/min]
 °F = 9/5°C + 32



Remote sensor unit
Integrated display

PF3W 5 04 [] - [] 03 - 1T [] - [] [] [] [] []
 PF3W 7 04 [] - [] 03 - AT [] - M [] [] [] []

Type

5	Remote sensor unit
7	Integrated display

Rated flow range (Flow range)

Symbol	Rated flow range
04	0.5 to 4 ℓ/min
20	2 to 16 ℓ/min
40	5 to 40 ℓ/min
11	10 to 100 ℓ/min

Thread type

—	Rc
N	NPT
F	G

Port size

Symbol	Port size	Rated flow range			
		04	20	40	11
03	3/8	●	●	—	—
04	1/2	—	●	—	—
06	3/4	—	—	●	●
10	1	—	—	—	●

Flow adjustment valve

Symbol	With/without flow adjustment valve	Rated flow rate			
		04	20	40	11
—	None	●	●	●	●
S	Yes	●	●	●	—

100 ℓ/min type is not available with flow adjustment valve.

Integrated display

Output specification/ Temperature sensor

Symbol	OUT1	OUT2		Temperature sensor
	Flow rate	Flow rate	Temperature	
A	NPN	NPN	—	None
B	PNP	PNP	—	
C	NPN	Analogue 1 to 5 V	—	
D	NPN	Analogue 4 to 20 mA	—	
E	PNP	Analogue 1 to 5 V	—	
F	PNP	Analogue 4 to 20 mA	—	
G	NPN	External input ^{Note 1)}	—	
H	PNP	External input ^{Note 1)}	—	
AT	NPN	(NPN) ^{Note 2)}	NPN	With temperature sensor
BT	PNP	(PNP) ^{Note 2)}	PNP	
CT	NPN	(Analogue 1 to 5 V) ^{Note 2)}	Analogue 1 to 5 V	
DT	NPN	(Analogue 4 to 20 mA) ^{Note 2)}	Analogue 4 to 20 mA	
ET	PNP	(Analogue 1 to 5 V) ^{Note 2)}	Analogue 1 to 5 V	
FT	PNP	(Analogue 4 to 20 mA) ^{Note 2)}	Analogue 4 to 20 mA	

Note 1) External input: The accumulated value, peak value, and bottom value can be reset.

Note 2) For units with temperature sensor, OUT2 can be set as either temperature output or flow rate output. Setting when shipped is for temperature output.

Options/Part No.

When optional parts are required separately, use the following part numbers to place an order.

Description	Part no.	Qty.	Note
Bracket ^{Note)}	ZS-40-K	1	For PF3W704/720/504/520 With 4 tapping screws (3 x 8)
	ZS-40-L	1	For PF3W740/540 With 4 tapping screws (3 x 8)
	ZS-40-M	1	For PF3W711/511 With 4 tapping screws (4 x 10)
Lead wire with M8 connector	ZS-40-A	1	Lead wire length (3 m)

Note) For units with flow adjustment valve, 2 brackets are required.

• Made to Order
 X109 Seal material EPDM
 (Refer to page 6.)

Calibration certificate (Only flow sensor)

—	None
A	With calibration certificate

* The certificate is written in both English and Japanese. Integrated display type with temperature sensor can only display flow rate.

Bracket (Option)

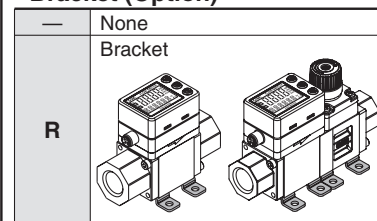

Integrated display/Unit specification

Symbol	Instantaneous flow rate	Accumulated flow	Temperature
M	ℓ/min	ℓ	°C
G	gal/min	gal	°C
F	gal/min	gal	°F
J	ℓ/min	ℓ	°F

Note) G, F, J: Made to Order
 Reference: 1 [ℓ/min] ↔ 0.2642 [gal/min]
 1 [gal/min] ↔ 3.785 [ℓ/min]
 °F = 9/5°C + 32

Lead wire

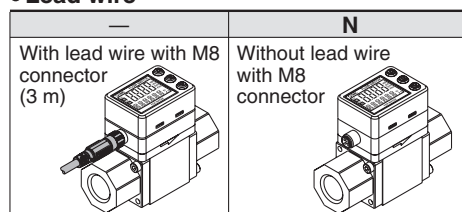

Specifications (Integrated Display)

Model	PF3W704	PF3W720	PF3W740	PF3W711
Applicable fluid	Water and ethylene glycol aqueous solution (with viscosity of 3 mPa·s [3 cP] or less) ^{Note 1)}			
Detection method	Karman vortex			
Rated flow range	0.5 to 4 ℓ/min	2 to 16 ℓ/min	5 to 40 ℓ/min	10 to 100 ℓ/min
Display flow range	0.35 to 5.50 ℓ/min (Flow under 0.35 ℓ/min is displayed as "0.00")	1.7 to 22.0 ℓ/min (Flow under 1.7 ℓ/min is displayed as "0.0")	3.5 to 55.0 ℓ/min (Flow under 3.5 ℓ/min is displayed as "0.0")	7 to 140 ℓ/min (Flow under 7 ℓ/min is displayed as "0")
Set flow range	0.35 to 5.50 ℓ/min	1.7 to 22.0 ℓ/min	3.5 to 55.0 ℓ/min	7 to 140 ℓ/min
Minimum setting unit	0.01 ℓ/min	0.1 ℓ/min		1 ℓ/min
Conversion of accumulated pulse (Pulse width: 50 ms)	0.05 ℓ/pulse	0.1 ℓ/pulse	0.5 ℓ/pulse	1 ℓ/pulse
Fluid temperature	0 to 90°C (with no freezing and condensation)			
Display unit	Instantaneous flow rate: ℓ/min, Accumulated flow: ℓ			
Accuracy	Display value: ±3% F.S. Analogue output: ±3% F.S.			
Repeatability	±2% F.S. ^{Note 2)}			
Temperature characteristics	±5% F.S. (25°C reference)			
Operating pressure range ^{Note 3)}	0 to 1 MPa			
Proof pressure ^{Note 3)}	1.5 MPa			
Pressure loss	45 kPa at the maximum flow (without flow adjustment valve)			
Accumulated flow range ^{Note 4)}	99999999.9 ℓ		999999999 ℓ	
	By 0.1 ℓ	By 0.5 ℓ	By 1 ℓ	
Switch output	NPN or PNP open collector output			
Maximum load current	80 mA			
Maximum applied voltage	28 VDC			
Internal voltage drop	NPN: 1 V or less (at 80 mA load current) PNP: 1.5 V or less (at 80 mA load current)			
Response time ^{Note 2), 5)}	0.5s / 1s / 2s			
Output protection	Short circuit protection			
Output mode	Select from hysteresis mode, window comparator mode, accumulated output mode, or accumulated pulse output mode.			
Temperature mode	Select from hysteresis mode or window comparator mode.			
Response time ^{Note 6)}	0.5s / 1s / 2s (linked with the switch output)			
Analogue output Voltage output	Voltage output: 1 to 5 V Output impedance: 1 kΩ			
Current output	Output current: 4 to 20 mA Max. load impedance: 300 Ω for 12 VDC, 600 Ω for 24 VDC			
Hysteresis	Variable			
External input	Voltage free input: 0.4 V or less (Reed or Solid state), input for 30 ms or longer			
Display method	2-screen display (Main screen: 4-digit, 7-segment, 2-colour, Red/Green Sub screen: 6-digit, 11-segment, White) Display values updated 5 times per second			
Indicator light	Output 1, Output 2: Orange			
Power supply voltage	12 to 24 VDC ±10%			
Current consumption	50 mA or less			
Environment Enclosure	IP65			
Operating temperature range	0 to 50°C (with no freezing and condensation)			
Operating humidity range	Operation, Storage: 35 to 85% R.H. (with no condensation)			
Withstand voltage ^{Note 7)}	1000 VAC for 1 minute between whole live part and enclosure			
Insulation resistance	50 MΩ or more (500 VDC mega metre) between whole live part and enclosure			
Standards and regulations	CE marking, UL (CSA), RoHS			
Wetted parts material ^{Note 8)}	PPS, Stainless steel 304, FKM, SCS13 Non-grease			
Piping port size	3/8	3/8, 1/2	1/2, 3/4	3/4, 1
Weight				
Without temperature sensor/Without flow adjustment valve	210 g	260 g	410 g	720 g
With temperature sensor/Without flow adjustment valve	285 g	335 g	530 g	860 g
Without temperature sensor/With flow adjustment valve	310 g	360 g	610 g	—
With temperature sensor/With flow adjustment valve	385 g	435 g	730 g	—
With lead wire with connector	+85 g			

- Note 1) Refer to "Measurable Range for Ethylene Glycol Aqueous Solution" on page 4. Measurement can be performed with a fluid that does not corrode wetted parts and has viscosity of 3 mPa·s [3 cP] or less.
- Note 2) When 0.5 s is selected for the response time of the switch output, the repeatability becomes ±3% F.S.
- Note 3) Operating pressure range and proof pressure change according to the fluid temperature. Refer to page 3.
- Note 4) Cleared by turning off the power supply. It is possible to select the function to memorise it. (Every 2 or 5 minutes) When 5 minutes memorising is selected, the lifetime of the memory element (electronic part) is 1 million times (5 minutes x 1 million times = 5 million minutes = Approx. 9.5 years for 24 hour energizing). Calculate the lifetime based on your operating conditions before using the memorising function, and do not exceed it.
- Note 5) The response time when the set value is 90% in relation to the step input. (The response time is 7 s when it is output by the temperature sensor.)
- Note 6) The response time until the set value reaches 90% in relation to the step input. (The response time is 7 s when it is analogue output by the temperature sensor.)
- Note 7) When the temperature sensor is used, it will be 250 VAC.
- Note 8) Refer to "Wetted Parts Construction" on page 7 for details.

Temperature Sensor Specifications

Rated temperature range	0 to 100°C ^{Note 1)}
Setting/Display temperature range	-10 to 110°C
Minimum setting unit	1°C
Display unit	°C
Display accuracy	±2°C
Analogue output accuracy	±3% F.S.
Response time	7 s ^{Note 2)}
Ambient temperature characteristics	±5% F.S.

- Note 1) The rated temperature range is for the temperature sensor alone.
The fluid temperature range specification of the flow switch as a whole is 0 to 90°C.
- Note 2) The response time is for the temperature sensor alone.

The output related to the temperature sensor is OUT2 only.

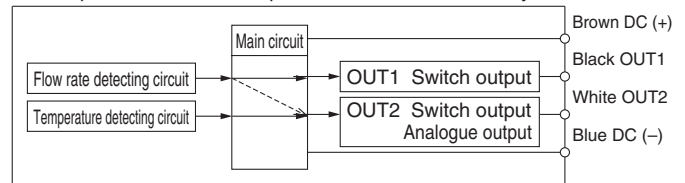

The OUT2 can be selected from the output for temperature or flow rate by button operation.

Series PF3W

Specifications (Remote Sensor Unit) Refer to page 17 for monitor specifications.

Model	PF3W504	PF3W520	PF3W540	PF3W511	
Applicable fluid	Water and ethylene glycol aqueous solution (with viscosity of 3 mPa·s [3 cP] or less) ^{Note 1)}				
Detection method	Karman vortex				
Rated flow range	0.5 to 4 ℓ/min	2 to 16 ℓ/min	5 to 40 ℓ/min	10 to 100 ℓ/min	
Fluid temperature	0 to 90°C (with no freezing and condensation)				
Accuracy	±3% F.S.				
Repeatability	±2% F.S.				
Temperature characteristics	±5% F.S. (25°C reference)				
Operating pressure range ^{Note 2)}	0 to 1 MPa ^{Note 2)}				
Proof pressure ^{Note 2)}	1.5 MPa				
Pressure loss	45 kPa or less at the maximum flow (without flow adjustment valve)				
Analogue output	Response time ^{Note 3)}	1 s			
	Voltage output	Voltage output: 1 to 5 V Output impedance: 1 kΩ			
	Current output	Output current: 4 to 20 mA Max. load impedance: 300 Ω for 12 VDC, 600 Ω for 24 VDC			
Indicator light	For power supply status, flow rate indicator (Blinking speed changes in response to flow rate), and other error indicator				
Power supply voltage	12 to 24 VDC ±10%				
Current consumption	30 mA or less				
Environment	Enclosure	IP65			
	Operating temperature range	0 to 50°C (with no freezing and condensation)			
	Operating humidity range	Operation, Storage: 35 to 85% R.H. (with no condensation)			
	Withstand voltage ^{Note 4)}	1000 VAC for 1 minute between whole live part and enclosure			
Insulation resistance	50 MΩ or more (500 VDC mega metre) between whole live part and enclosure				
Standards and regulations	CE marking, UL (CSA), RoHS				
Wetted parts material ^{Note 5)}	PPS, Stainless steel 304, FKM, SCS13				
Piping port size	Non-grease				
Weight	Without temperature sensor/Without flow adjustment valve	195 g	245 g	395 g	705 g
	With temperature sensor/Without flow adjustment valve	270 g	320 g	515 g	840 g
	Without temperature sensor/With flow adjustment valve	295 g	345 g	595 g	—
	With temperature sensor/With flow adjustment valve	370 g	415 g	715 g	—
	With lead wire with connector	+85 g			

- Note 1) Refer to "Measurable Range for Ethylene Glycol Aqueous Solution" on page 4. Measurement can be performed with a fluid that does not corrode wetted parts and has viscosity of 3 mPa·s [3 cP] or less.
- Note 2) Operating pressure range and proof pressure change according to the fluid temperature. Refer to the graphs below.
- Note 3) The response time until the set value reaches 90% in relation to the step input. (The response time is 7 s when it is analogue output by the temperature sensor.)
- Note 4) When the temperature sensor is used, it will be 250 VAC.
- Note 5) Refer to "Wetted Parts Construction" on page 7 for details.

Analogue Output

Flow rate/Analogue output

	A	B	C
Voltage output	1 V	1.5 V (1.4 V)	5 V
Current output	4 mA	6 mA (5.6 mA)	20 mA

Values in parentheses are for the PF3W711/511.

Model	Rated flow [ℓ/min]	
	Minimum	Maximum
PF3W704/504	0.5	4
PF3W720/520	2	16
PF3W740/540	5	40
PF3W711/511	10	100

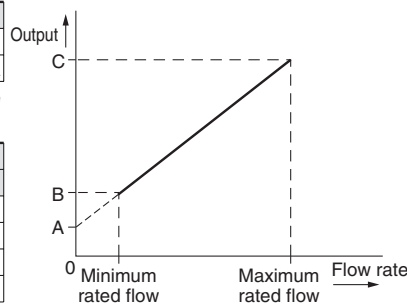

Fluid temperature/Analogue output PF3W7/5

	A	B
Voltage output	0.6 V	1 V
Current output	2.4 mA	4 mA

	C	D
Voltage output	5 V	5.4 V
Current output	20 mA	21.6 mA

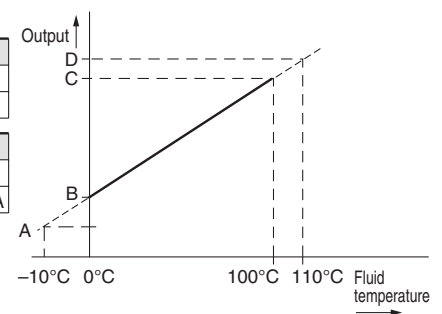

Operating Pressure and Proof Pressure

PF3W704/720/740/504/520/540

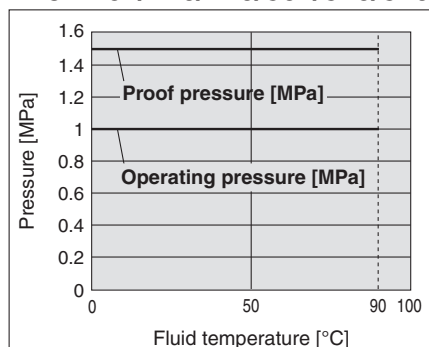

PF3W704S/720S/740S/504S/520S/540S

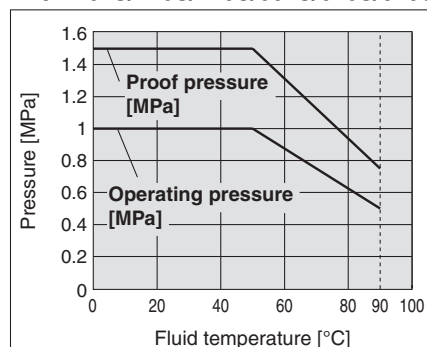

PF3W711/511

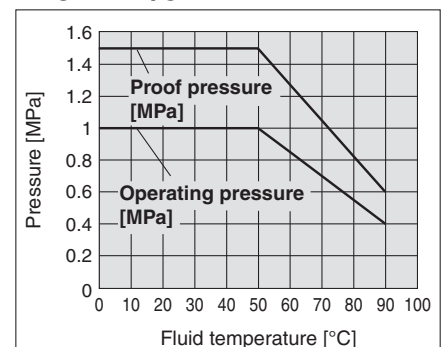

Temperature Sensor Specifications

Rated temperature range	0 to 100°C ^{Note 1)}
Analogue output accuracy	±3% F.S.
Response time	7 s ^{Note 2)}
Ambient temperature characteristics	±5% F.S.

Note 1) The rated temperature range is for the temperature sensor alone. The fluid temperature range specification of the flow switch as a whole is 0 to 90°C.

Note 2) The response time is for the temperature sensor alone.

Flow-rate Characteristics (Pressure Loss: Without Flow Adjustment Valve)

PF3W704/504

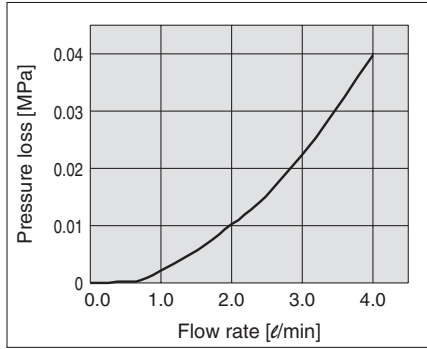

PF3W720/520

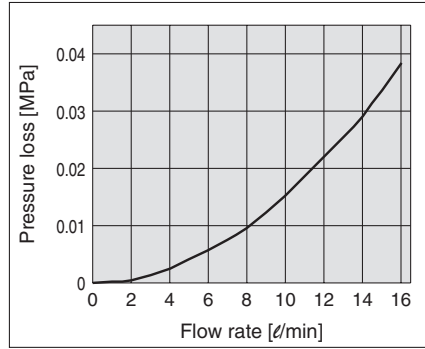

PF3W740/540

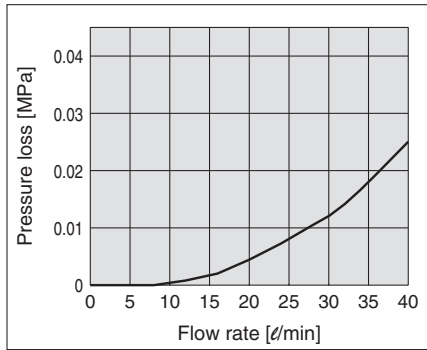

PF3W711/511

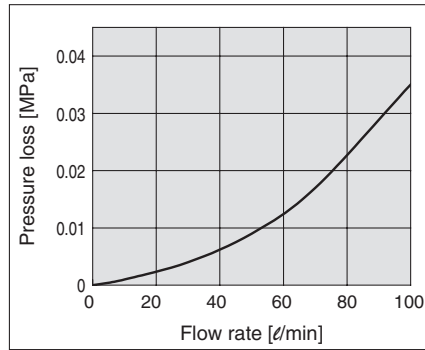

Straight Piping Length and Accuracy (Reference Value)

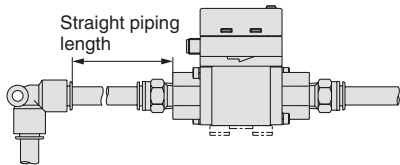

- The smaller the piping size, the more the product is affected by the straight piping length.
- Fluid pressure has almost no affect.
- Low flow rate lessens the effect of the straight piping length.
- Use a straight pipe that is 8 cm or longer in length to satisfy the $\pm 3\%$ F.S. specification. (11 cm or longer for 100 L/min type)

PF3W704/504

Pressure: 0.3 MPa
Piping diameter: $\phi 12$

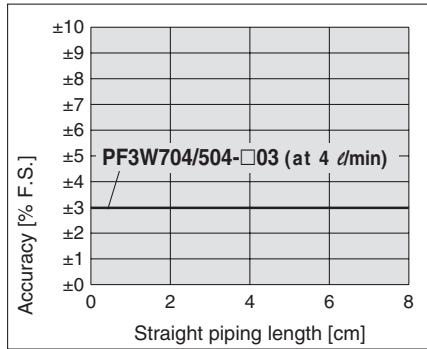

PF3W720/520

Pressure: 0.3 MPa
Piping diameter: $\phi 12$

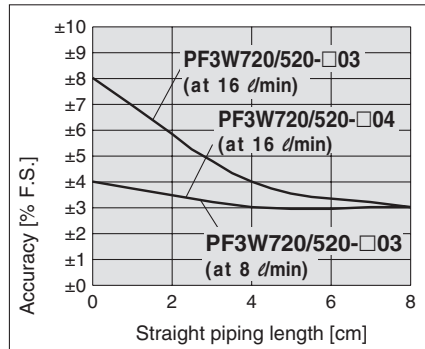

PF3W740/540

Pressure: 0.3 MPa
Piping diameter: $\phi 16$

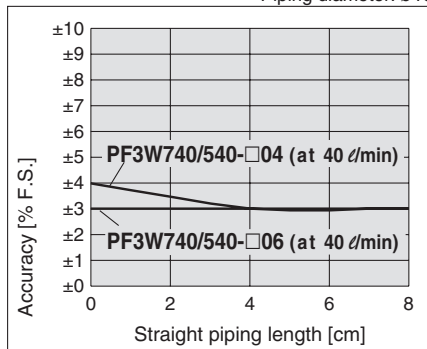

PF3W711/511

Pressure: 0.3 MPa Piping diameter: 25A (Port size 10)
20A (Port size 06)

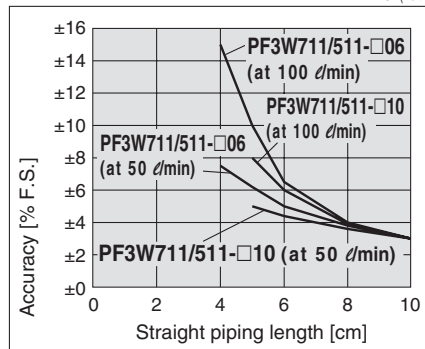

Flow-rate Characteristics of Flow Adjustment Valve

PF3W704S/504S

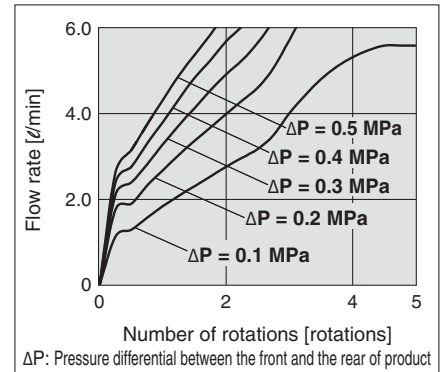

PF3W720S/520S

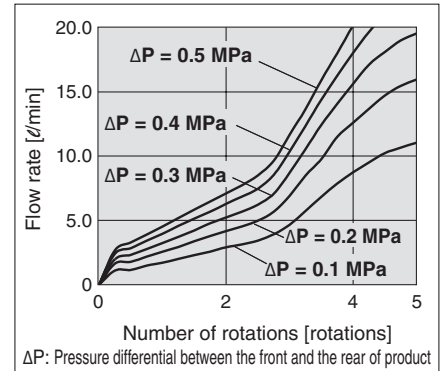

PF3W740S/540S

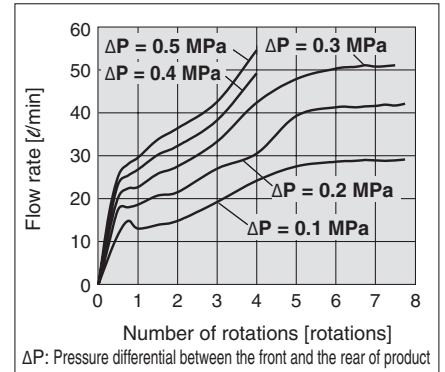

Measurable Range for Ethylene Glycol Aqueous Solution (Reference Value)

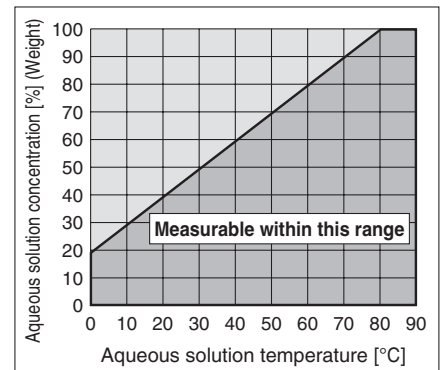

* No data for 4 cm, or for under 5 cm, as these cannot be used due to piping dimensions.

Series PF3W

Example of Internal Circuit and Wiring/Series PF3W7 (Integrated Display)

NPN 2 Output type
PF3W7□□-□□-A(T)-□□□

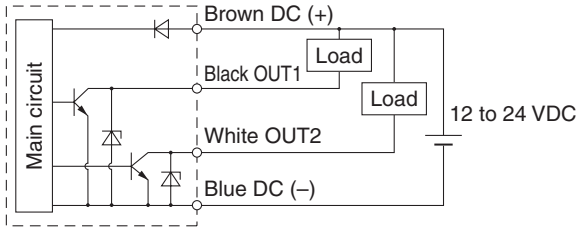

PNP 2 Output type
PF3W7□□-□□-B(T)-□□□

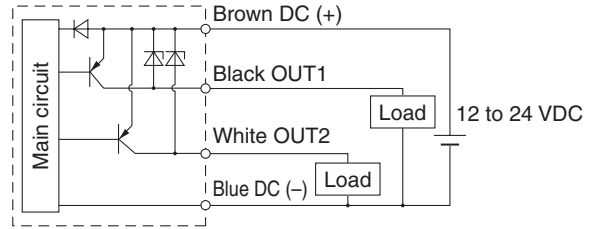

NPN + Analogue output type
PF3W7□□-□□-C(T)-□□□

NPN + Analogue output type
PF3W7□□-□□-D(T)-□□□

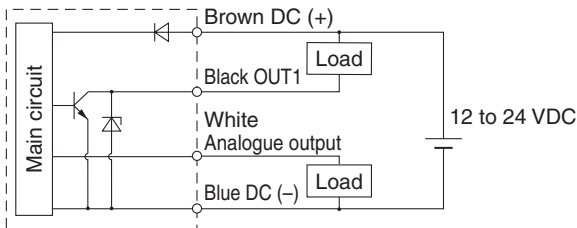

PNP + Analogue output type
PF3W7□□-□□-E(T)-□□□

PNP + Analogue output type
PF3W7□□-□□-F(T)-□□□

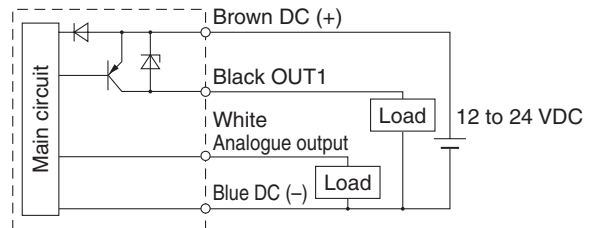

NPN + External input type
PF3W7□□-□□-G-□□□

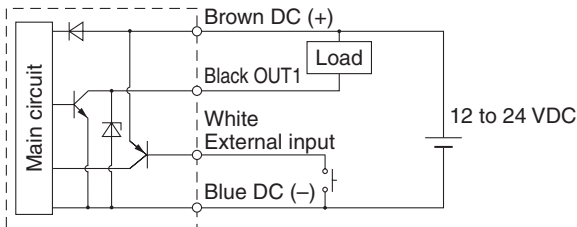

PNP + External input type
PF3W7□□-□□-H-□□□

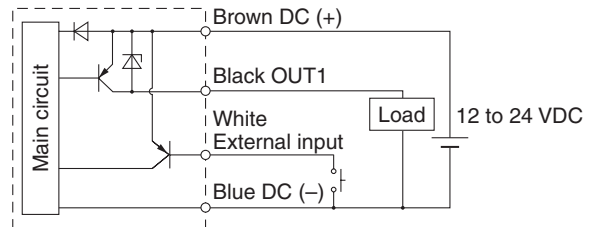

Example of wiring for accumulated pulse output

NPN 2 Output type
PF3W7□□-□□-A(T)-□□

NPN + Analogue output type
PF3W7□□-□□-C(T)-□□/PF3W7□□-□□-D(T)-□□

NPN + External input type
PF3W7□□-□□-G-□□

PNP 2 Output type
PF3W7□□-□□-B(T)-□□

PNP + Analogue output type
PF3W7□□-□□-E(T)-□□/PF3W7□□-□□-F(T)-□□

PNP + External input type
PF3W7□□-□□-H-□□

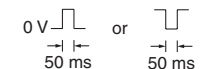
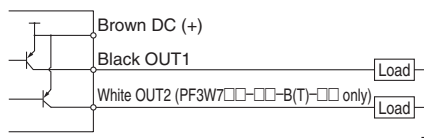
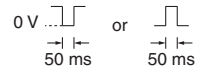
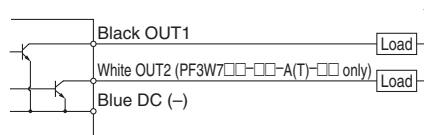

When accumulated pulse output is selected, indicator light turns off.

Example of Internal Circuit and Wiring/Series PF3W5 (Remote Sensor Unit)

Analogue 2 Output type
PF3W5□□-□□-□□□

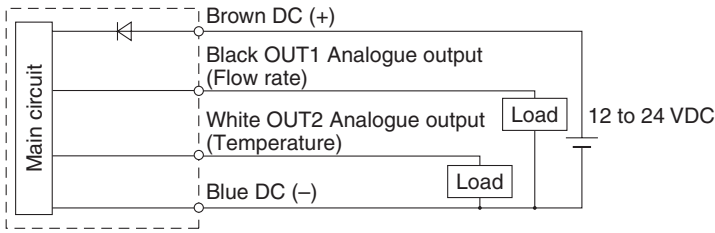

OUT2 (white wire) only for units with temperature sensor

Made to Order



Please consult SMC for detailed dimensions, specifications and delivery.

Seal material for wetted parts changed to EPDM

Symbol
-X109

PF3W5 □□ - □□ - □□□□ - □□□□ - X109

PF3W7 □□ - □□ - □□□□ - □□□□ - X109

• Seal material EPDM

Refer to "How to Order," page 1 for details.

Note) Not compatible with units with flow adjustment valve.
Please special-order separately.

Series PF3W

Description

Main unit

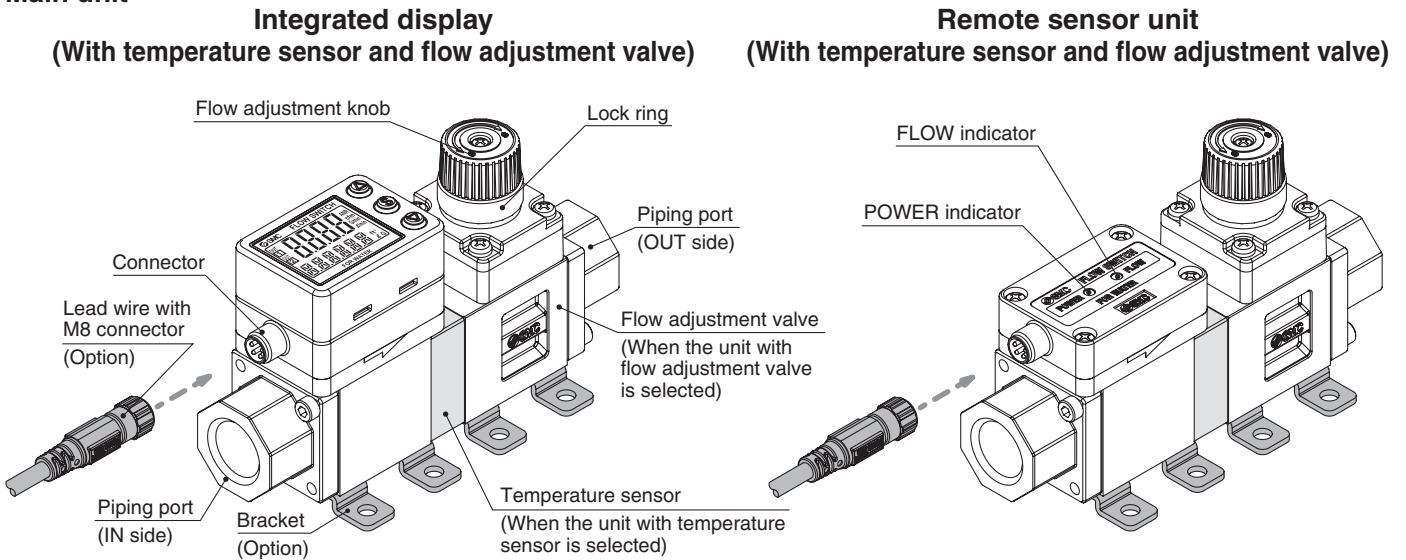

Description	Function
Connector	Connects the lead wire.
Lead wire with M8 connector	Supplies power to the product and ensures output.
Piping port	Connects to the piping. Inlet piping goes to the IN side, and outlet piping goes to the OUT side.
Bracket	Mounting bracket for installation of the product
Temperature sensor	Detects the fluid temperature.
Flow adjustment valve	Orifice mechanism to adjust the flow rate.
Flow adjustment knob	Adjusts the flow rate.
Lock ring	Fixes the flow adjustment knob in place.
POWER indicator	Indicates the power supply status, indicates product specifications and indicates errors.
FLOW indicator	Blinks at a cycle proportional to the flow rate or indicates errors. Turns off when below rated flow.

Display

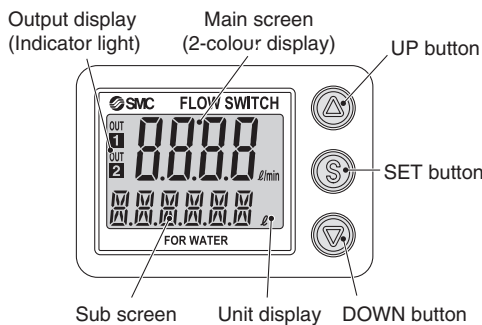

Description	Function
Main screen (2-colour display)	Displays the flow, status of setting mode, and error code.
Sub screen	Displays the accumulated flow, set value, peak/bottom value, fluid temperature, and line name. In the setting mode, the set status is displayed. (Refer to page 21 for details.)
Output display (Indicator light)	Displays the output status of OUT1 and OUT2. When ON: Orange light turns on.
Unit display	Displays the unit selected.
UP button	Selects the mode and the display shown on the sub screen, and increases the ON/OFF set values.
SET button	Press this button to change the mode and to set a set value.
DOWN button	Selects the mode and the display shown on the sub screen, and decreases the ON/OFF set values.

Wetted Parts Construction

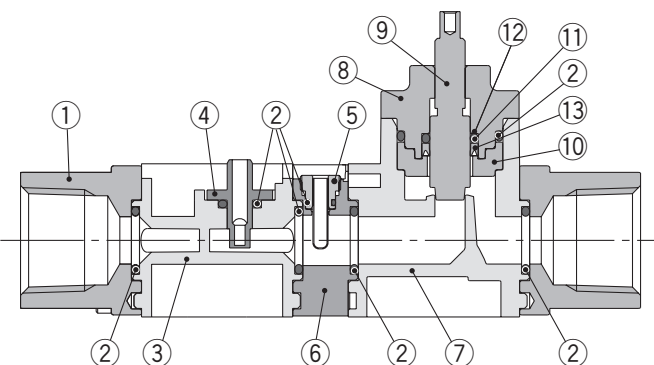

Component Parts

No.	Description	Material	Note
1	Attachment	SCS13	Stainless steel 304 equivalent
2	Seal	FKM	
3	Body	PPS	
4	Sensor	PPS	
5	Temperature sensor	Stainless steel 304	With brazing (JIS Z 3261: BAg-7, ISO 3677: B-Ag56CuZnSn-620/650)
6	Temperature sensor body	Stainless steel 304	
7	Flow adjustment valve body	PPS	
8	Flow adjustment valve cover	PPS	
9	Flow adjustment valve shaft	Stainless steel 304	
10	Shaft support	PPS	
11	O-ring	FKM	
12	Cap seal	FKM	
13	Y seal	FKM	

Dimensions

PF3W704/720/740/711 Integrated display

Connector
pin number

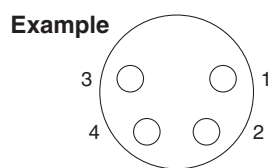

Pin no.	Pin name
1	DC (+)
2	OUT2
3	DC (-)
4	OUT1

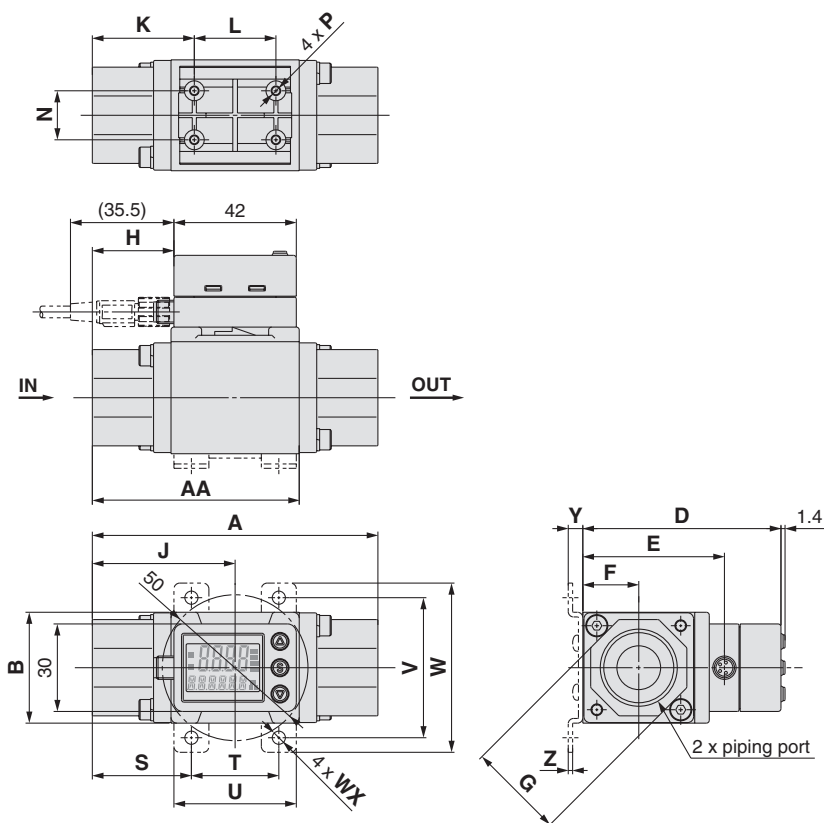

PF3W504/520/540/511 Remote sensor unit

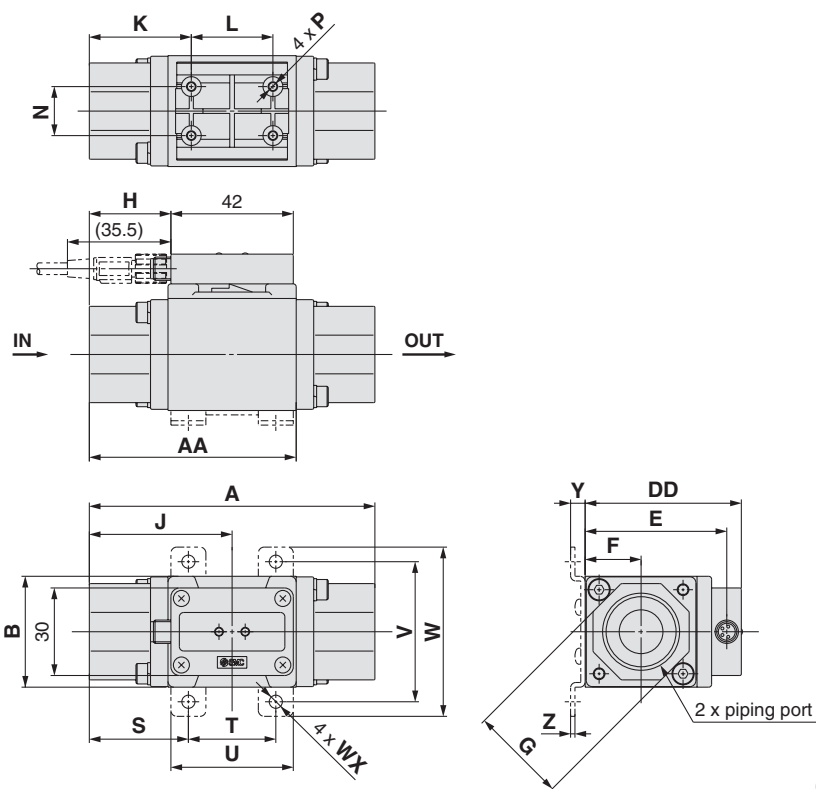

Model	Port size (Rc, NPT, G)	A	AA	B	D	DD	E	F	G	H	J	K	L	N	P	Bracket dimensions							
																S	T	U	V	W	WX	Y	Z
PF3W704/504	3/8	70	50	30	60	45.6	40.6	15.2	24	14	35	26	18	13.6	ø2.7 depth 14	24	22	32	40	50	4.5	5	1.5
PF3W720/520	3/8, 1/2	78	54	30	60	45.6	40.6	15.2	27	18	39	30	18	13.6	ø2.7 depth 12	28	22	32	40	50	4.5	5	1.5
PF3W740/540	1/2, 3/4	98	71	38	68	53.6	48.6	19.2	32	28	49	35	28	16.8	ø2.7 depth 12	34	30	42	48	58	4.5	5	1.5
PF3W711/511	3/4, 1	124	92	46	77	62.6	57.6	23.0	41	42	63	48	28	18.0	ø3.5 depth 14	44	36	48	58	70	5.5	7	2.0

Series PF3W

Dimensions

PF3W704/720/740/711-□-□T

Integrated display: With temperature sensor

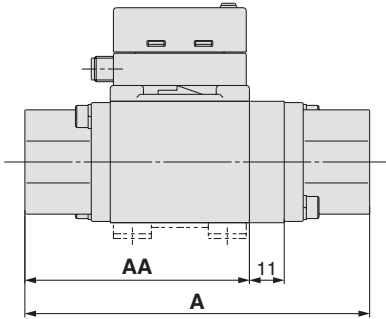

PF3W504/520/540/511-□-□T

Remote sensor unit: With temperature sensor

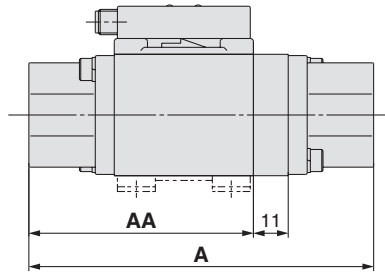

(mm)

Model	A	AA
PF3W704/504-□-□T	81	50
PF3W720/520-□-□T	89	54
PF3W740/540-□-□T	109	71
PF3W711/511-□-□T	135	92

PF3W704S/720S/740S

Integrated display: With flow adjustment valve

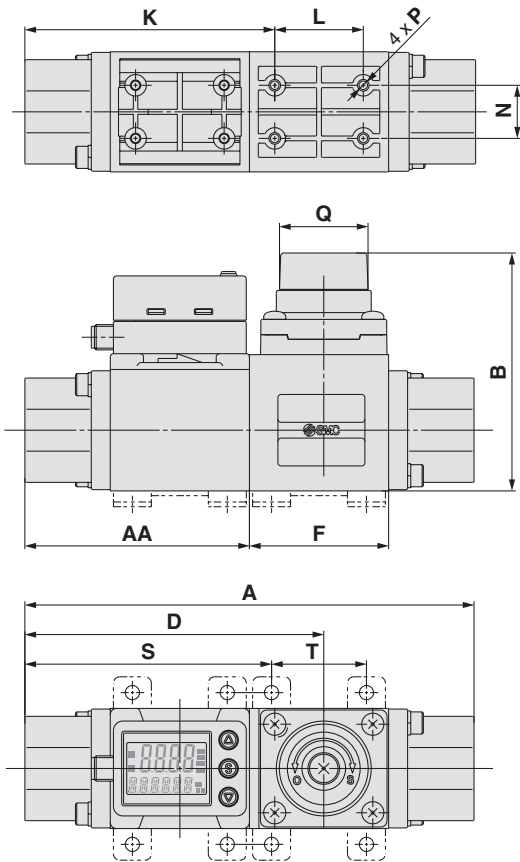

PF3W504S/520S/540S

Remote sensor unit: With flow adjustment valve

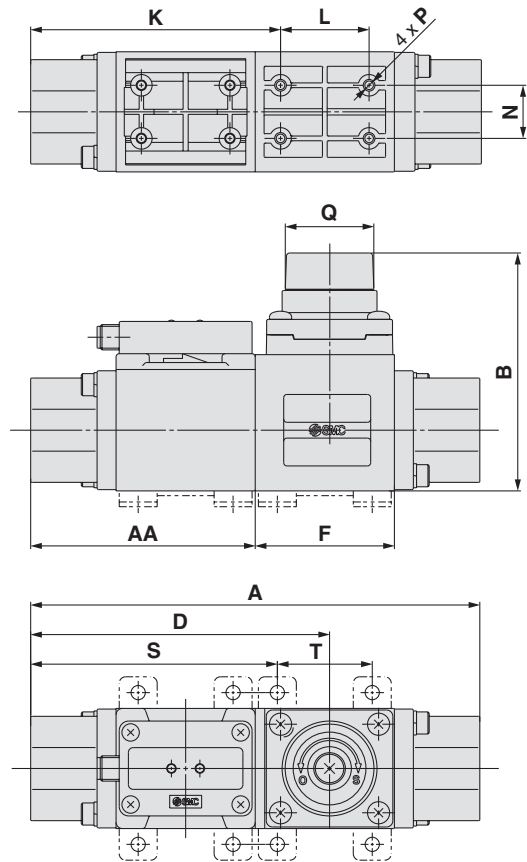

(mm)

Model	A	AA	B	D	F	K	L	N	P	Q	Q number of rotations	Bracket dimensions	
												S	T
PF3W704S/504S	104	50	63.6 (Max. 68.6)	70.2	34	58.5	18	13.6	ø2.7 depth 10	ø19	6	56.5	22
PF3W720S/520S	112	54	63.6 (Max. 68.6)	74.2	34	62.5	18	13.6	ø2.7 depth 10	ø19	6	60.5	22
PF3W740S/540S	142	71	75.25 (Max. 81)	94.5	44	79.0	28	16.8	ø2.7 depth 10	ø28	7	78.0	30

Dimensions

PF3W704S/720S/740S-□-□T

Integrated display: With temperature sensor and flow adjustment valve

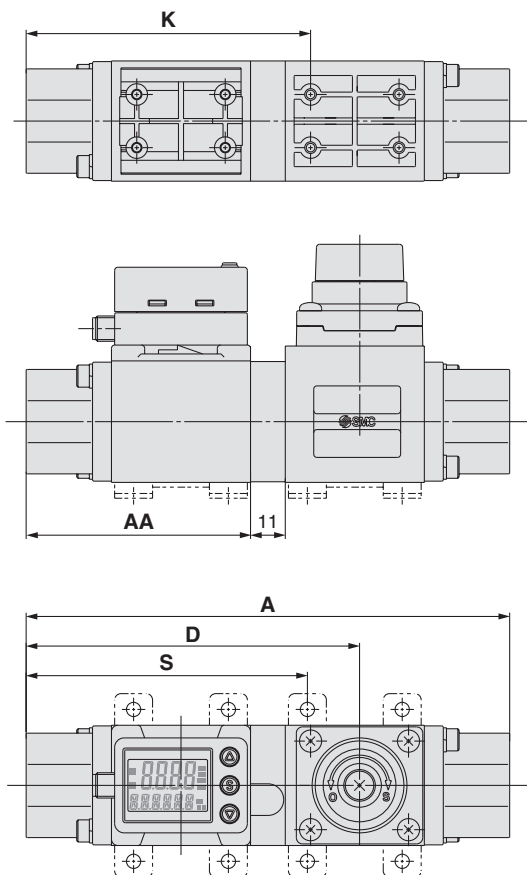

PF3W504S/520S/540S-□-□T

Remote sensor unit: With temperature sensor and flow adjustment valve

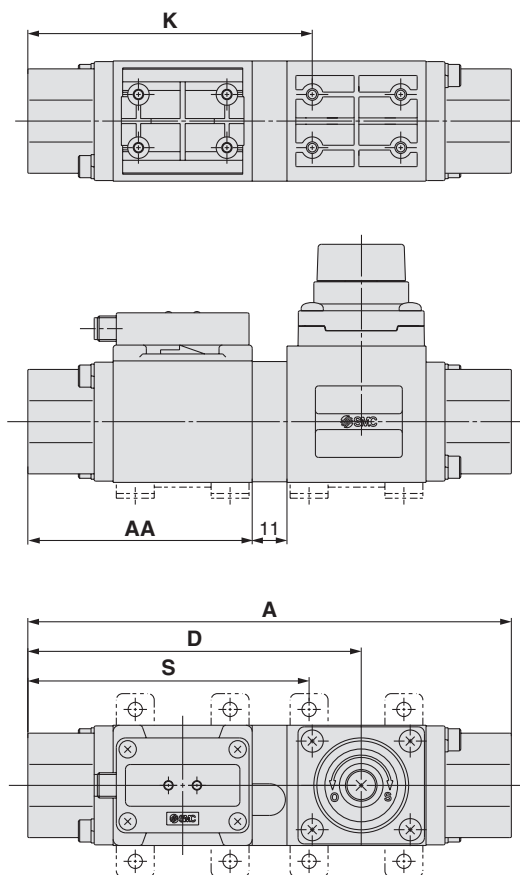

(mm)

Model	A	AA	D	K	S
PF3W704S/504S-□-□T	115	50	81.2	69.5	67.5
PF3W720S/520S-□-□T	123	54	85.2	73.5	71.5
PF3W740S/540S-□-□T	153	71	105.5	90.0	89.0

ZS-40-A

Lead wire with M8 connector

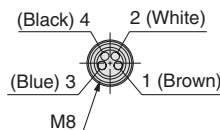
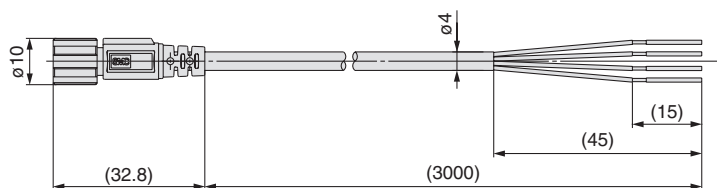

Pin no.	Pin name	Wire colour
1	DC (+)	Brown
2	OUT2	White
3	DC (-)	Blue
4	OUT1	Black

Note) 4-wire type lead wire with M8 connector used for the PF3W series.

Lead Wire Specifications

Conductor	Nominal cross section	AWG23
	O.D.	Approx. 0.7 mm
Insulator	Material	Heat resistant PVC
	O.D.	Approx. 1.1 mm
Sheath	Material	Heat and oil resistant PVC
	Finished O.D.	ø4

3-Colour Display Digital Flow Switch for Water
PF3W

3-Colour Display Digital Flow Switch for PVC Piping
PF3W

3-Colour Display Digital Flow Monitor for Water
PF3W3

Function
Details

3-colour display



Digital Flow Switch for PVC Piping

Series PF3W

How to Order

Remote sensor unit/
Unit printed on label

Symbol	Instantaneous flow rate	Accumulated flow	Temperature
—	ℓ/min	ℓ	°C
G	gal/min	gal	°C
F	gal/min	gal	°F
J	ℓ/min	ℓ	°F

Note) G, F, J: Made to Order

Reference: 1 [ℓ/min] ↔ 0.2642 [gal/min]

1 [gal/min] ↔ 3.785 [ℓ/min]

°F = 9/5°C + 32

Calibration certificate
(Only flow sensor)

—	None
A	With calibration certificate

* The certificate is written in both English and Japanese.

Bracket (Option)

—	None
R	Bracket

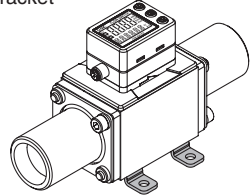

Integrated display/Unit specification

Symbol	Instantaneous flow rate	Accumulated flow	Temperature
M	ℓ/min	ℓ	°C
G	gal/min	gal	°C
F	gal/min	gal	°F
J	ℓ/min	ℓ	°F

Note) G, F, J: Made to Order

Reference: 1 [ℓ/min] ↔ 0.2642 [gal/min]

1 [gal/min] ↔ 3.785 [ℓ/min]

°F = 9/5°C + 32

Lead wire

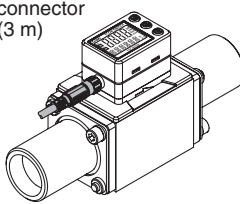
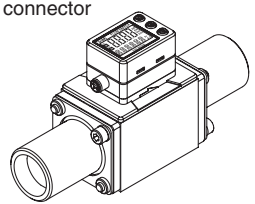
—	N
With lead wire with M8 connector (3 m)	Without lead wire with M8 connector
	

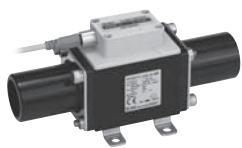

Remote sensor unit

Integrated display



Remote sensor unit/Output specification

Symbol	OUT1
1	Analogue 1 to 5 V
2	Analogue 4 to 20 mA

PF3W 5 11 - U 25 - 1

PF3W 7 11 - U 25 - A

Type

5	Remote sensor unit
7	Integrated display

Rated flow range
(Flow range)

Symbol	Rated flow range
11	10 to 100 ℓ/min

Connection type

U	PVC pipe
---	----------

PVC pipe O.D.

Symbol	Port size
25	25A

Integrated display/Output specification

Symbol	OUT1	OUT2
A	NPN	NPN
B	PNP	PNP
C	NPN	Analogue 1 to 5 V
D	NPN	Analogue 4 to 20 mA
E	PNP	Analogue 1 to 5 V
F	PNP	Analogue 4 to 20 mA
G	NPN	External input
H	PNP	External input

External input: The accumulated value, peak value, and bottom value can be reset.

Options/Part No.

When optional parts are required separately, use the following part numbers to place an order.

Description	Part no.	Qty.	Note
Bracket	ZS-40-M	1	With 4 tapping screws (4 x 10)
Lead wire with M8 connector	ZS-40-A	1	Lead wire length (3 m)

Specifications (Integrated Display)

Model		PF3W711
Applicable fluid		Water and ethylene glycol aqueous solution (with viscosity of 3 mPa·s [3 cP] or less) ^{Note 1)}
Detection method		Karman vortex
Rated flow range		10 to 100 ℓ/min
Display flow range		7 to 140 ℓ/min (Flow under 7 ℓ/min is displayed as "0")
Set flow range		7 to 140 ℓ/min
Minimum setting unit		1 ℓ/min
Conversion of accumulated pulse		1 ℓ/pulse
Fluid temperature		0 to 70°C (with no freezing and condensation)
Display unit		Instantaneous flow rate: ℓ/min, Accumulated flow: ℓ, Display values updated 5 times per second
Accuracy		Display value: ±3% F.S. Analogue output: 3% F.S.
Repeatability		±2% F.S. ^{Note 2)}
Temperature characteristics		±5% F.S. (25°C reference)
Operating pressure range ^{Note 3)}		0 to 1 MPa
Proof pressure ^{Note 3)}		1 MPa
Pressure loss		45 kPa or less at the maximum flow
Accumulated flow range ^{Note 4)}		999999999 ℓ By 1 ℓ
Switch output		NPN or PNP open collector output
	Maximum load current	80 mA
	Maximum applied voltage	28 VDC
	Internal voltage drop	NPN: 1 V or less (at 80 mA load current) PNP: 1.5 V or less (at 80 mA load current)
	Response time ^{Note 2), 5)}	0.5s / 1s / 2s
	Output protection	Short circuit protection
	Output mode Flow rate	Select from hysteresis mode, window comparator mode, accumulated output mode, or accumulated pulse output mode.
Analogue output	Response time ^{Note 6)}	0.5s / 1s / 2s (linked with the switch output)
	Voltage output	Voltage output: 1 to 5 V Output impedance: 1 kΩ
	Current output	Output current: 4 to 20 mA Max. load impedance: 300 Ω for 12 VDC, 600 Ω for 24 VDC
Hysteresis		Variable
External input		Voltage free input: 0.4 V or less (Reed or Solid state), input for 30 ms or longer
Display method		2-screen display (Main screen: 4-digit, 7-segment, 2-colour, Red/Green Sub screen: 6-digit, 11-segment, White)
Indicator light		Output 1, Output 2: Orange
Power supply voltage		12 to 24 VDC ±10%
Current consumption		50 mA or less
Environment	Enclosure	IP65
	Operating temperature range	0 to 50°C (with no freezing and condensation)
	Operating humidity range	Operation, Storage: 35 to 85% R.H. (with no condensation)
	Withstand voltage	1000 VAC for 1 minute between whole live part and enclosure
Insulation resistance		50 MΩ or more (500 VDC mega metre) between whole live part and enclosure
Standards and regulations		CE marking, UL (CSA), RoHS
Wetted parts material ^{Note 7)}		PPS, FKM, CPVC
Piping port size		Non-grease 25A
Weight	Without lead wire with connector	285 g
	With lead wire with connector	370 g

Note 1) Refer to "Measurable Range for Ethylene Glycol Aqueous Solution" on page 4. Measurement can be performed with a fluid that does not corrode wetted parts and has viscosity of 3 mPa·s [3 cP] or less. Refer to the list of applicable fluids on page 24.

Note 2) When 0.5 s is selected for the response time of the switch output, the repeatability becomes ±3% F.S.

Note 3) Operating pressure range and proof pressure change according to the fluid temperature. Refer to page 13.

Note 4) Cleared by turning off the power supply. It is possible to select the function to memorise it. (Every 2 or 5 minutes) When 5 minutes memorising is selected, the lifetime of the memory element (electronic part) is 1 million times (5 minutes x 1 million times = 5 million minutes = Approx. 9.5 years for 24 hour energizing). Calculate the lifetime based on your operating conditions before using the memorising function, and do not exceed it.

Note 5) The response time when the set value is 90% in relation to the step input.

Note 6) The response time until the set value reaches 90% in relation to the step input.

Note 7) Refer to "Wetted Parts Construction" on page 14 for details.

Specifications (Remote Sensor Unit)

Refer to page 17 for monitor specifications.

Model		PF3W511
Applicable fluid		Water and ethylene glycol aqueous solution (with viscosity of 3 mPa·s [3 cP] or less) ^{Note 1)}
Detection method		Karman vortex
Rated flow range		10 to 100 ℓ/min
Fluid temperature		0 to 70°C (with no freezing and condensation)
Accuracy		±3% F.S.
Repeatability		±2% F.S.
Temperature characteristics		±5% F.S. (25C reference)
Operating pressure range ^{Note 2)}		0 to 1 MPa ^{Note 2)}
Proof pressure ^{Note 2)}		1 MPa
Pressure loss		45 kPa or less at the maximum flow
Analogue output	Response time ^{Note 3)}	1 s
	Voltage output	Voltage output: 1 to 5 V Output impedance: 1 kΩ
	Current output	Output current: 4 to 20 mA Max. load impedance: 300 Ω for 12 VDC, 600 Ω for 24 VDC
Indicator light		For power supply status, flow rate indicator (Blinking speed changes in response to flow rate), and other error indicator
Power supply voltage		12 to 24 VDC ±10%
Current consumption		30 mA or less
Environment	Enclosure	IP65
	Operating temperature range	0 to 50°C (with no freezing and condensation)
	Operating humidity range	Operation, Storage: 35 to 85% R.H. (with no condensation)
	Withstand voltage	1000 VAC for 1 minute between whole live part and enclosure
	Insulation resistance	50 MΩ or more (500 VDC mega metre) between whole live part and enclosure
Standards and regulations		CE marking, UL (CSA), RoHS
Wetted parts material ^{Note 4)}		PPS, FKM, CPVC
Piping port size		Non-grease 25A
Weight	Without lead wire with connector	270 g
	With lead wire with connector	355 g

Note 1) Refer to "Measurable Range for Ethylene Glycol Aqueous Solution" on page 4. Measurement can be performed with a fluid that does not corrode wetted parts and has viscosity of 3 mPa·s [3 cP] or less. Refer to the list of applicable fluids on page 24.

Note 2) Operating pressure range and proof pressure change according to the fluid temperature. Refer to the graphs below.

Note 3) The response time until the set value reaches 90% in relation to the step input.

Note 4) Refer to "Wetted Parts Construction" on page 14 for details.

Analogue Output

Flow rate/Analogue output

	A	B	C
Voltage output	1 V	1.4 V	5 V
Current output	4 mA	5.6 mA	20 mA

Model	Rated flow [ℓ/min]	
	Minimum	Maximum
PF3W711/511	10	100

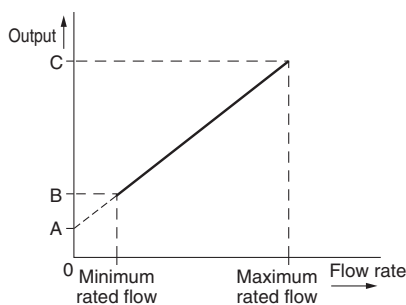

Operating Pressure

PF3W711/511 (for PVC Piping)

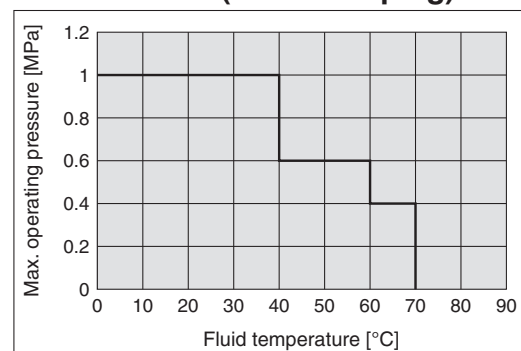

Flow-rate Characteristics (Pressure Loss)

PF3W711/511

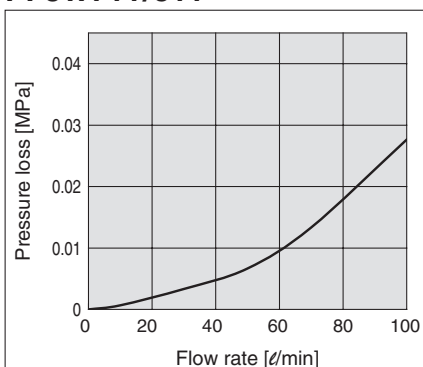

Straight Piping Length and Accuracy (Reference Value)

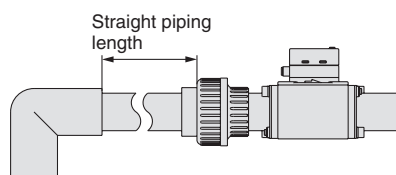

- Fluid pressure has almost no effect.
- To maintain ±3% F.S. in the specifications, use a straight pipe that is 11 cm or longer in length.

PF3W711/511

Pressure: 0.3 MPa
Piping diameter: 25A

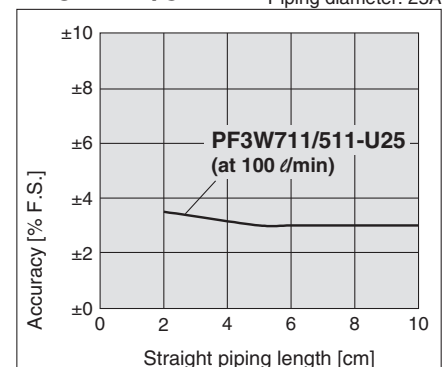

For measurable range for ethylene glycol aqueous solution (reference values), refer to page 4. For examples of internal circuit and wiring, refer to pages 5 to 6.

Description

Main unit

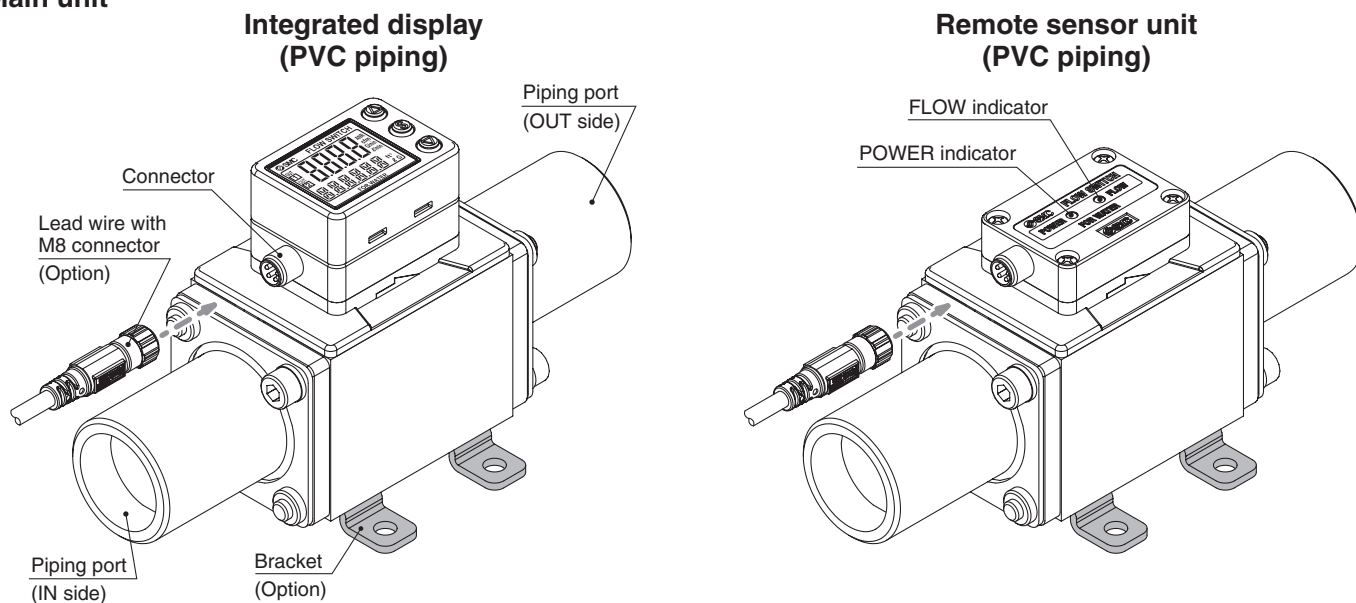

Description	Function
Connector	Connects the lead wire.
Lead wire with M8 connector	Supplies power to the product and ensures output.
Piping port	Connects to the piping. Inlet piping goes to the IN side, and outlet piping goes to the OUT side.
Bracket	Mounting bracket for installation of the product.
POWER indicator	Indicates the power supply status, indicates product specifications and indicates errors.
FLOW indicator	Blinks at a cycle proportional to the flow rate or indicates errors. Turns off when below rated flow.

Display

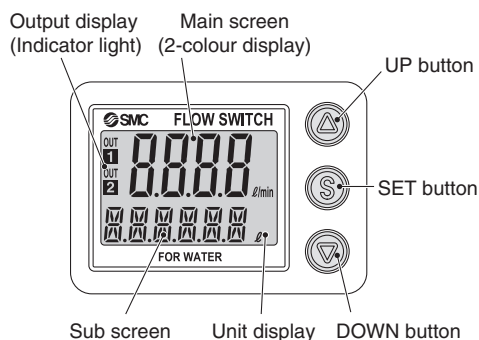

Description	Function
Main screen (2-colour display)	Displays the flow, status of setting mode, and error code.
Sub screen	Displays the accumulated flow, set value, peak/bottom value, fluid temperature, and line name. In the setting mode, the set status is displayed. (Refer to page 21 for details.)
Output display (Indicator light)	Displays the output status of OUT1 and OUT2. When ON: Orange light turns on.
Unit display	Displays the unit selected.
UP button	Selects the mode and the display shown on the sub screen, and increases the ON/OFF set values.
SET button	Press this button to change the mode and to set a set value.
DOWN button	Selects the mode and the display shown on the sub screen, and decreases the ON/OFF set values.

Wetted Parts Construction

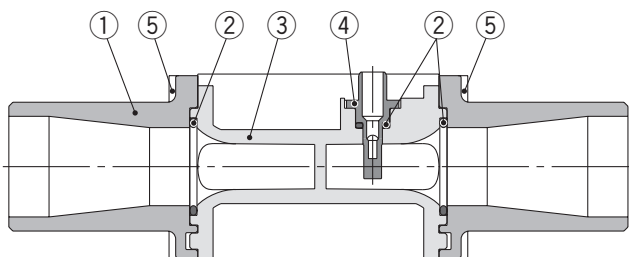

Component Parts

No.	Description	Material	Note
1	PVC pipe	CPVC	
2	Seal	FKM	
3	Body	PPS	
4	Sensor	PPS	

Replacement Parts

No.	Description	Part no.	Qty.
1	PVC pipe	ZS-40-U25	1
5	25A retaining plate (M5 x 80 with two hexagonal socket head cap screws)	ZS-40-U25-A	1

* Replacing the PVC pipe may cause accuracy to fluctuate by 1 to 2%.

Series PF3W

Dimensions

PF3W711-U25A Integrated display

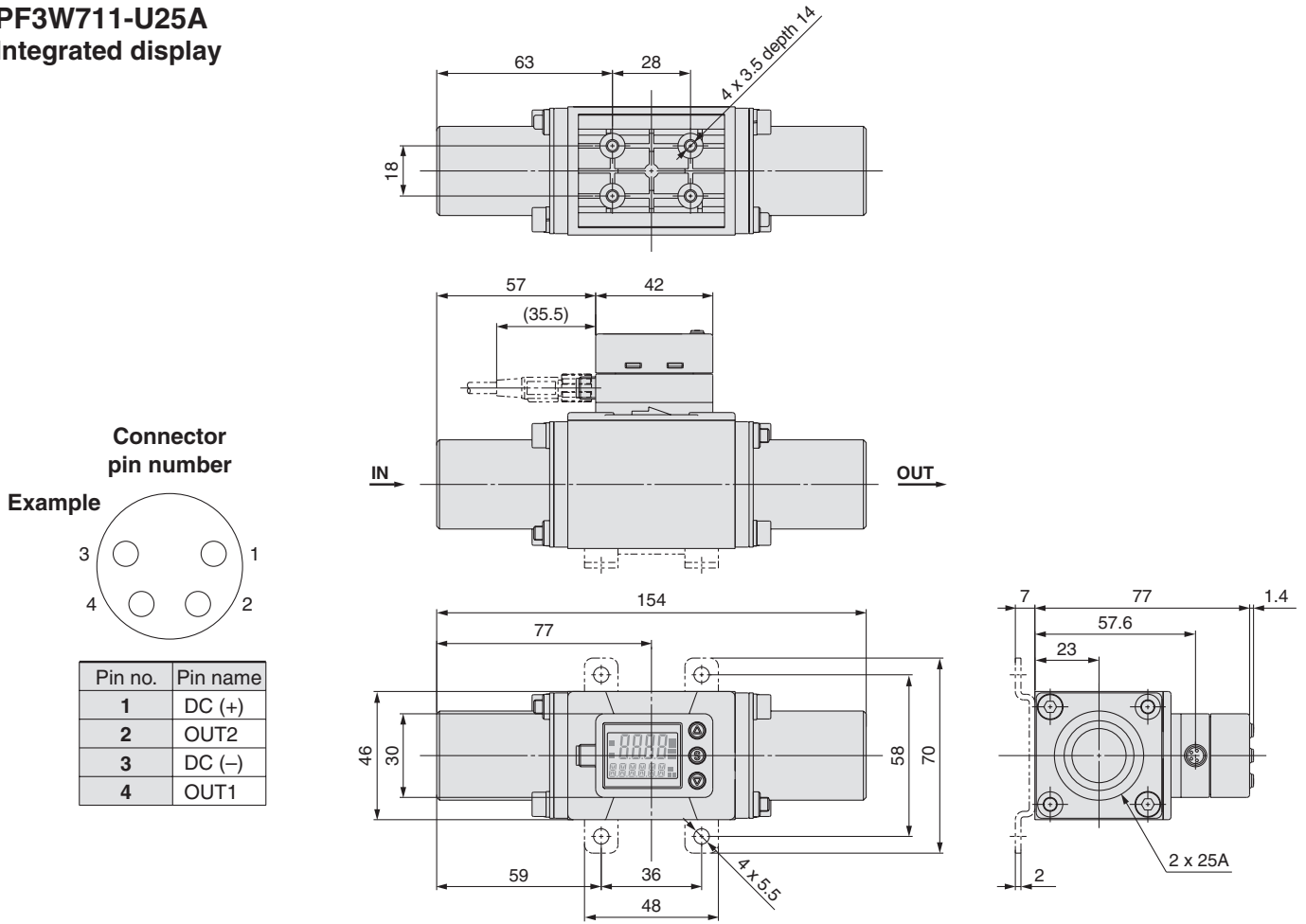

PF3W511-U25A Remote sensor unit

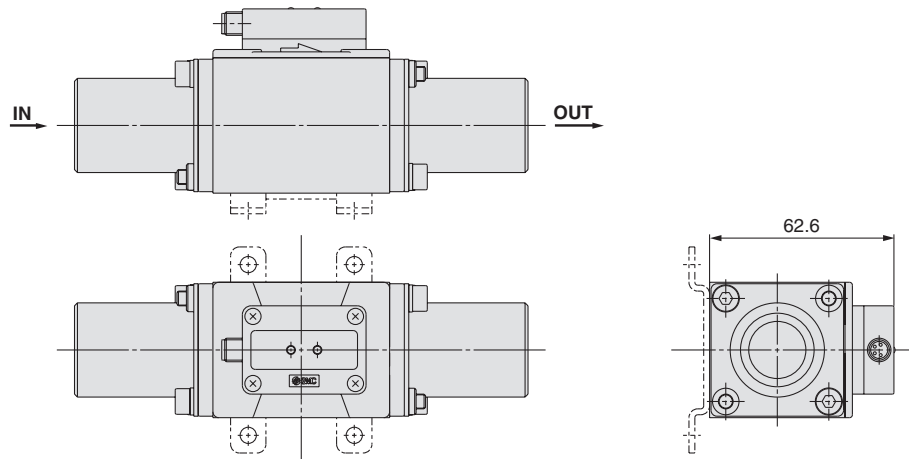

ZS-40-A Lead wire with M8 connector

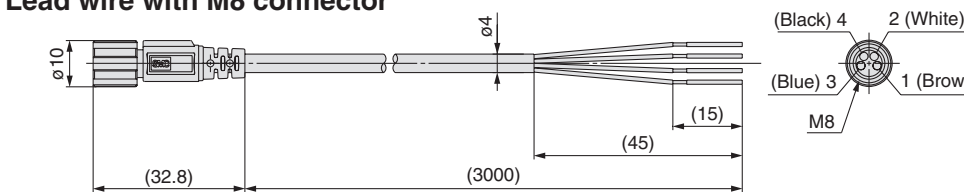

Pin no.	Pin name	Wire colour
1	DC (+)	Brown
2	OUT2	White
3	DC (-)	Blue
4	OUT1	Black

Note) 4-wire type lead wire with M8 connector used for the PF3W series.

Lead Wire Specifications

Conductor	Nominal cross section		
	O.D.	Approx. 0.7 mm	
Insulator	Material	Heat resistant PVC	
	O.D.	Approx. 1.1 mm	
Sheath	Material	Heat and oil resistant PVC	
	Finished O.D.	ø4	

3-colour display



RoHS

Digital Flow Monitor for Water Series PF3W3



How to Order

PF3W 30 **A** **□** - **M** **V** **C** **□**

Type

3 Remote monitor unit

For remote sensor units, select the analog output 1 to 5 V type.
Applicable sensors: PF3W5□□-□□-1(T)

Output specification

Symbol	OUT1	OUT2
A	NPN	NPN
B	PNP	PNP
C	NPN	Analogue 1 to 5 V
D	NPN	Analogue 4 to 20 mA
E	PNP	Analogue 1 to 5 V
F	PNP	Analogue 4 to 20 mA
G	NPN	External input
H	PNP	External input
J	Analogue 1 to 5 V	Analogue 1 to 5 V
K	Analogue 4 to 20 mA	Analogue 4 to 20 mA

In combination with remote sensor unit with temperature sensor, only OUT2 can be set for temperature sensor output.

Lead wire

With power supply/output connection lead wire (2 m)

Power supply/output connection lead wire ZS-40-W

N Without power supply/output connection lead wire

Lead wire is not connected, but shipped together.

Remote monitor unit/Unit specification

Symbol	Instantaneous flow rate	Accumulated flow	Temperature
M	ℓ/min	ℓ	°C
G	gal/min	gal	°C
F	gal/min	gal	°F
J	ℓ/min	ℓ	°F

Note) G, F, J: Made to Order
Reference: 1 [ℓ/min] ↔ 0.2642 [gal/min]
1 [gal/min] ↔ 3.785 [ℓ/min]
°F = 9/5°C + 32

Calibration certificate (Only flow monitor)

—	None
A	With calibration certificate

* The certificate is written in both English and Japanese.

Option 2

—	None
C	Sensor connector (1 pc.)

Sensor connector (e-con)

Connector is not connected, but shipped together.

Option 1

—	None
T	Panel mount adapter

Panel mount adapter

Waterproof seal (accessory)

Panel

Mounting screw (M3 x 8 L) (accessory)

V	Front protective cover + Panel mount adapter
----------	--

Front protective cover

Panel mount adapter

Waterproof seal (accessory)

Panel

Mounting screw (M3 x 8 L) (accessory)

Options/Part No.

When optional parts are required separately, use the following part numbers to place an order.

Description	Part no.	Note
Panel mount adapter	ZS-26-B	With waterproof seal and screws
Front protective cover + Panel mount adapter	ZS-26-C	With waterproof seal and screws
Front protective cover only	ZS-26-01	Separately order panel mount adapter, etc.
Power supply/output connection lead wire	ZS-40-W	Lead wire length (2 m)
Sensor connector (e-con)	ZS-28-CA-4	1 pc.
Lead wire with connector for copying	ZS-40-Y	Connect up to 10 slave units

Series PF3W3

Specifications

Model	PF3W3□			
Display flow range	0.35 to 4.50 ℓ/min <small>(Flow under 0.35 ℓ/min is displayed as "0.00")</small>	1.7 to 18.0 ℓ/min <small>(Flow under 1.7 ℓ/min is displayed as "0.0")</small>	3.5 to 45.0 ℓ/min <small>(Flow under 3.5 ℓ/min is displayed as "0.0")</small>	7 to 112 ℓ/min <small>(Flow under 7 ℓ/min is displayed as "0")</small>
Set flow range	0.35 to 4.50 ℓ/min	1.7 to 18.0 ℓ/min	3.5 to 45.0 ℓ/min	7 to 112 ℓ/min
Minimum setting unit	0.01 ℓ/min	0.1 ℓ/min		1 ℓ/min
Conversion of accumulated pulse	0.05 ℓ/pulse	0.1 ℓ/pulse	0.5 ℓ/pulse	1 ℓ/pulse
Display unit	Instantaneous flow rate: ℓ/min, Accumulated flow: ℓ			
Accuracy	Display value: ±0.5% F.S. Analogue output: ±0.5% F.S.			
Repeatability	±0.5% F.S.			
Temperature characteristics	±0.5% F.S. (25C reference)			
Accumulated flow range <small>Note 1)</small>	99999999.9 ℓ		99999999 ℓ	
	By 0.1 ℓ	By 0.5 ℓ	By 1 ℓ	
Switch output	NPN or PNP open collector output			
Maximum load current	80 mA			
Maximum applied voltage	28 VDC			
Internal voltage drop	NPN: 1 V or less (at 80 mA load current) PNP: 1.5 V or less (at 80 mA load current)			
Response time <small>Note 2)</small>	1s / 2s			
Output protection	Short circuit protection			
Output mode	Select from hysteresis mode, window comparator mode, accumulated output mode, or accumulated pulse output mode.			
Flow rate mode	Select from hysteresis mode or window comparator mode.			
Temperature mode				
Response time <small>Note 3)</small>	1s / 2s (linked with the switch output)			
Analogue output Voltage output	Voltage output: 1 to 5 V Output impedance: 1 kΩ			
Current output	Output current: 4 to 20 mA Max. load impedance: 300 Ω for 12 VDC, 600 Ω for 24 VDC			
Hysteresis	Variable			
External input	Voltage free input: 0.4 V or less (Reed or Solid state), input for 30 ms or longer			
Input/output	Input for copy mode			
Display method	2-screen display (Main screen: 4-digit, 7-segment, 2-colour, Red/Green Sub screen: 6-digit, 11-segment, White), Display values updated 5 times per second			
Indicator light	Output 1, Output 2: Orange			
Power supply voltage	12 to 24 VDC ±10%			
Current consumption	50 mA or less			
Connection	Power supply output 5P connector, sensor connection 4P connector (e-con)			
Environment	Enclosure	IP40 (Only front face of the panel is IP65 when panel mount adapter and waterproof seal of optional parts are used.)		
	Operating temperature range	0 to 50°C (with no freezing and condensation)		
	Operating humidity range	Operation, Storage: 35 to 85% R.H. (with no condensation)		
	Withstand voltage	1000 VAC for 1 minute between whole live part and enclosure		
Insulation resistance	50 M or more (500 VDC mega metre) between whole live part and enclosure			
Standards and regulations	CE marking, UL (CSA), RoHS			
Weight	Without power supply/output connection lead wire	50 g		
	With power supply/output connection lead wire	100 g		

Note 1) Cleared by turning off the power supply. It is possible to select the function to memorise it. (Every 2 or 5 minutes) When 5 minutes memorising is selected, the lifetime of the memory element (electronic part) is 1 million times (5 minutes x 1 million times = 5 million minutes = Approx. 9.5 years for 24 hour energizing).

Calculate the lifetime based on your operating conditions before using the memorising function, and do not exceed it.

Note 2) The response time when the set value is 90% in relation to the step input. (The response time is 7 s when it is output by the temperature sensor.)

Note 3) The response time until the set value reaches 90% in relation to the step input. (The response time is 7 s when it is analogue output by the temperature sensor.)

Temperature Sensor Specifications

Rated temperature range	0 to 100°C <small>Note 1)</small>
Setting/Display temperature range	-10 to 110°C
Minimum setting unit	1°C
Display unit	°C
Analogue output accuracy	±3% F.S.
Response time	7 s <small>Note 2)</small>
Ambient temperature characteristics	±5% F.S.

Note 1) The rated temperature range is for the temperature sensor alone.
The fluid temperature range specification of the flow switch as a whole is 0 to 90°C.

Note 2) The response time is for the temperature sensor alone.

Analogue Output

Flow rate/Analogue output

	A	B	C
Voltage output	1 V	1.5 V (1.4 V)	5 V
Current output	4 mA	6 mA (5.6 mA)	20 mA

Values in parentheses are for the combination with the PF3W511.

Model	Rated flow [ℓ/min]	
	Minimum	Maximum
PF3W504	0.5	4
PF3W520	2	16
PF3W540	5	40
PF3W511	10	100

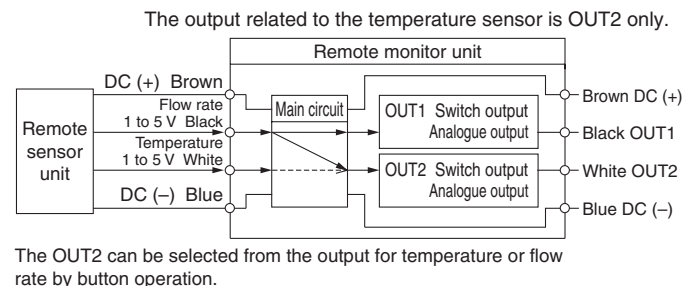
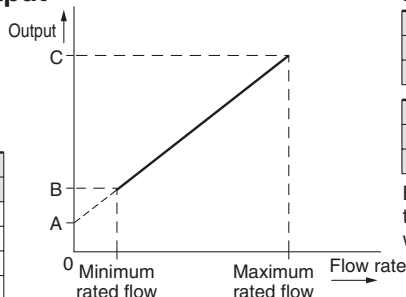

Fluid temperature/Analogue output

	A	B
Voltage output	0.6 V	1 V
Current output	2.4 mA	4 mA

	C	D
Voltage output	5 V	5.4 V
Current output	20 mA	21.6 mA

Be sure to use in combination with remote sensor units with temperature sensor.

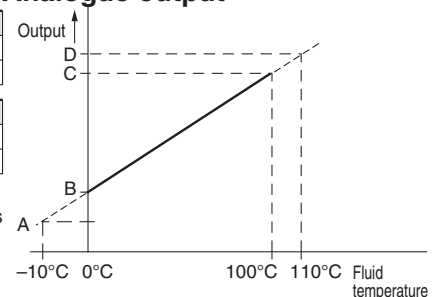

Example of Internal Circuit and Wiring

**NPN 2 Output type
PF3W30A**

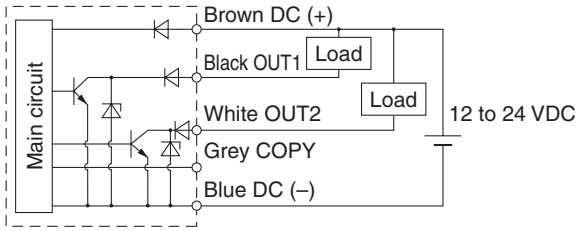

**PNP 2 Output type
PF3W30B**

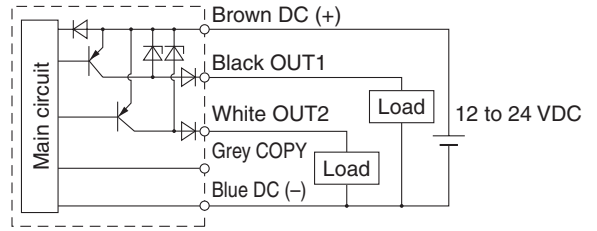

**NPN + Analogue output type
PF3W30C**

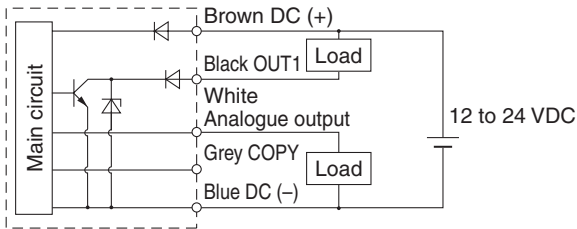

**NPN + Analogue output type
PF3W30D**

**PNP + Analogue output type
PF3W30E**

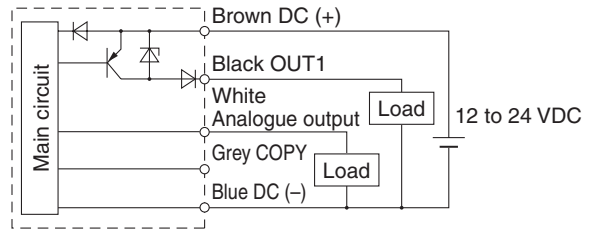

**NPN + External input type
PF3W30G**

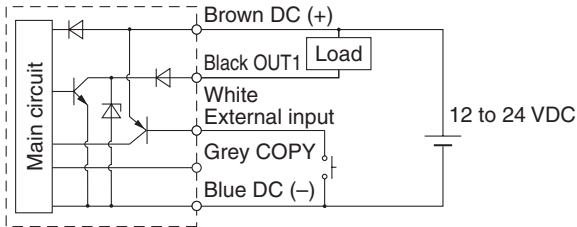

**PNP + External input type
PF3W30H**

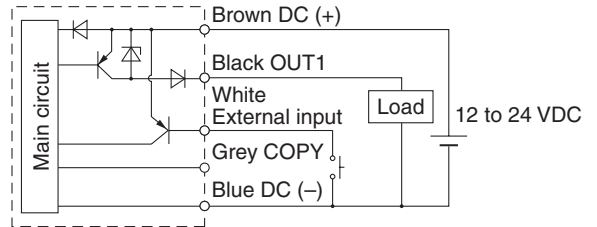

**Analogue 2 Output type
PF3W30J/PF3W30K**

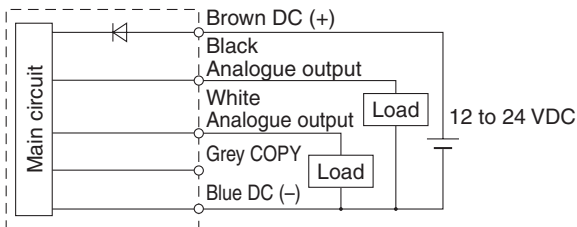

Sensor input circuit

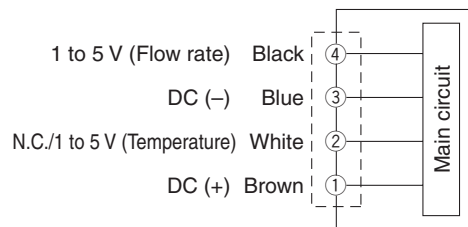

3-Colour Display Digital Flow Switch for Water
PF3W

3-Colour Display Digital Flow Switch for PVC Piping
PF3W

3-Colour Display Digital Flow Monitor for Water
PF3W3

Function
Details

Series PF3W3

Example of Internal Circuit and Wiring

Wiring example of accumulated pulse output

NPN 2 Output type

PF3W30A

NPN + Analogue output type

PF3W30C/PF3W30D

NPN + External input type

PF3W30G

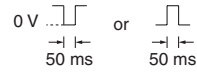
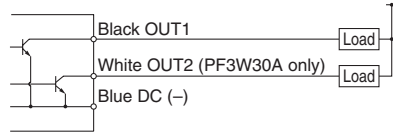

PNP 2 Output type

PF3W30B

PNP + Analogue output type

PF3W30E/PF3W30F

PNP + External input type

PF3W30H

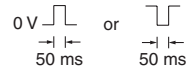
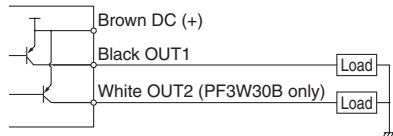

When accumulated pulse output is selected, indicator light turns off.

Description (Remote Monitor Unit)

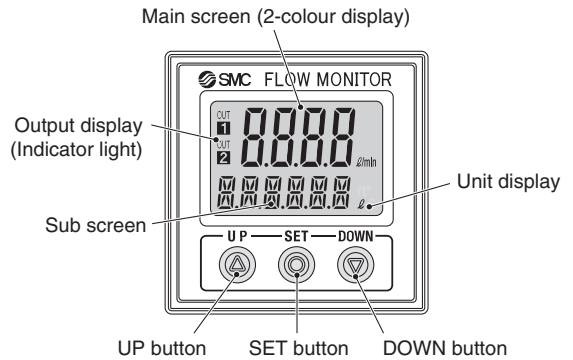
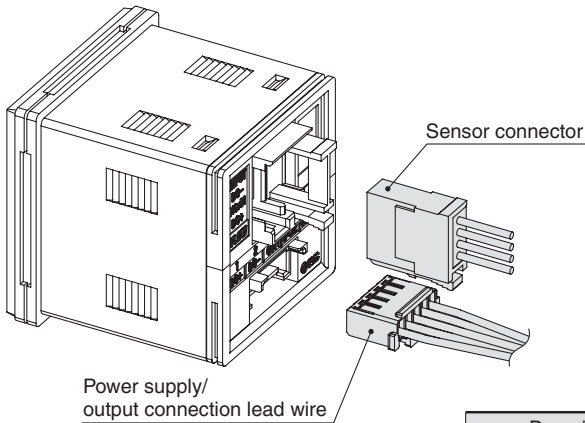

Description	Function
Main screen (2-colour display)	Displays the flow, status of setting mode, and error code.
Sub screen	Displays the accumulated flow, set value, peak/bottom value, fluid temperature, and line name. In the setting mode, the set status is displayed. (Refer to page 21 for details.)
Output display (Indicator light)	Displays the output status of OUT1 and OUT2. When ON: Orange light turns on.
Unit display	Displays the unit selected.
UP button	Selects the mode and the display shown on the sub screen, and increases the ON/OFF set values.
SET button	Press this button to change the mode and to set a set value.
DOWN button	Selects the mode and the display shown on the sub screen, and decreases the ON/OFF set values.

Sensor connector

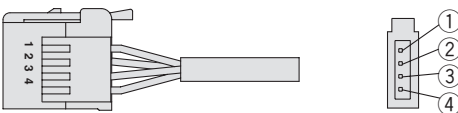

Pin no.	Terminal	Connector no.	Lead wire colour*
①	DC (+)	1	Brown
②	N.C./IN	2	White (Not used/Temperature sensor 1 to 5 V input)
③	DC (-)	3	Blue
④	INPUT	4	Black (Flow rate sensor 1 to 5 V input)

* When using the lead wire with M8 connector included with the PF3W5 series

Power supply/output connection lead wire

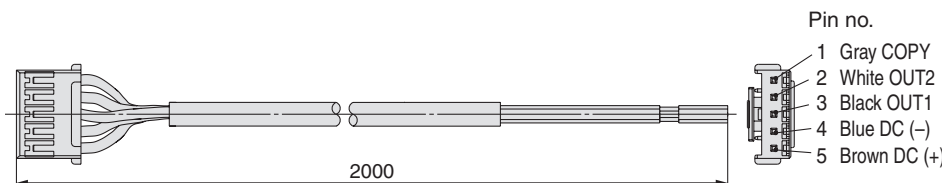

Lead Wire Specifications

Conductor	Nominal cross section	AWG26
	O.D.	Approx. 0.5 mm
Insulator	Material	Cross-linked vinyl
	O.D.	Approx. 1.0 mm
Sheath	Material	Brown, Blue, Black, White, Grey
	Finished O.D.	Oil and heat resistant vinyl
		ø3.5

Dimensions

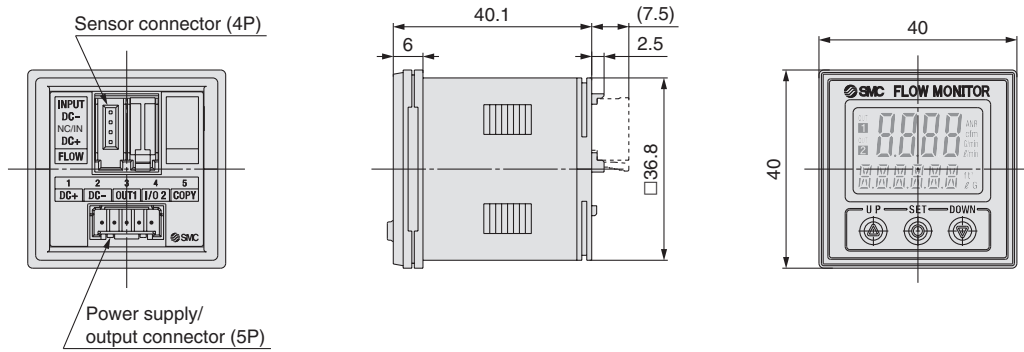

Front protective cover + Panel mount adapter

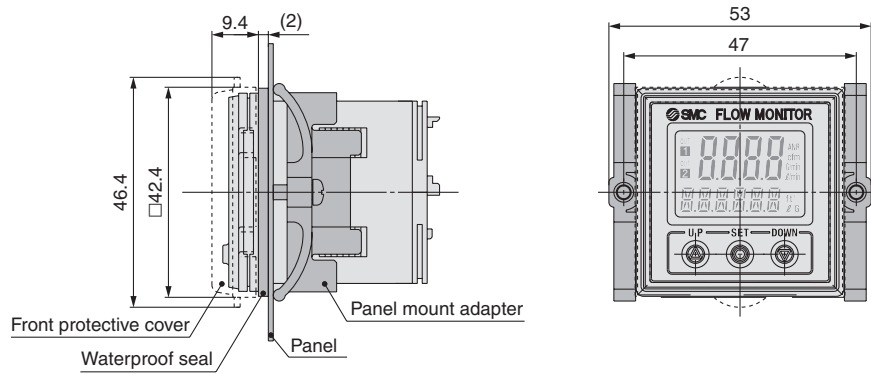

Panel fitting dimensions

Applicable panel thickness:
 0.5 to 8 mm (Without waterproof seal)
 0.5 to 6 mm (With waterproof seal)

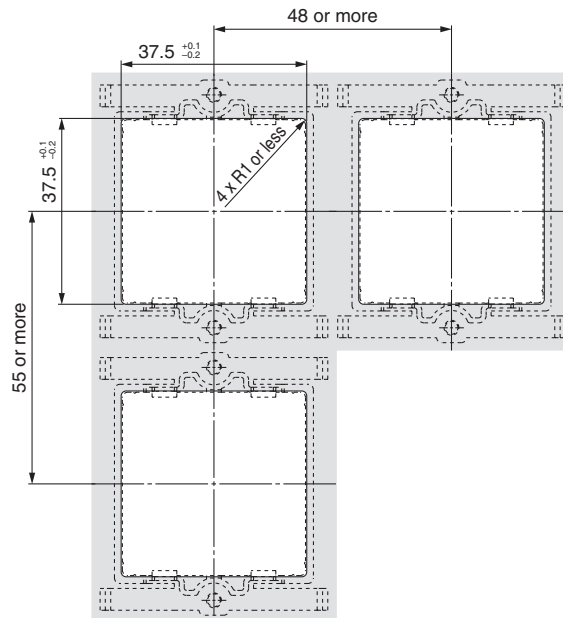

3-Colour Display Digital Flow Switch for Water
PF3W

3-Colour Display Digital Flow Switch for PVC Piping
PF3W

3-Colour Display Digital Flow Monitor for Water
PF3W3

Function
Details

Function Details 1

Integrated Display (Series PF3W7)/Remote Monitor Unit (Series PF3W3)

Output operation

The output operation can be selected from the following:
 Output (hysteresis mode and window comparator mode) corresponding to instantaneous flow rate,
 Output corresponding to accumulated flow,
 Accumulated pulse output

Note) At the time of shipment from the factory, it is set to hysteresis mode and normal output.

When a temperature sensor is attached, the output to the temperature sensor is selectable only for OUT2.
 (Refer to "How to Order" for details.)

Indication colour

The indication colour can be selected for each output condition. The selection of the indication colour provides visual identification of abnormal values. (The indication colour depends on OUT1 setting.)

ON: Green, OFF: Red
ON: Red, OFF: Green
Always: Red
Always: Green

Response time

The response time can be selected depending on the application. (1 second for default setting)

Abnormalities can be detected more quickly by setting the response time to 0.5 seconds.

The effect of the pump fluctuation and flickering of the display can be reduced by setting the response time to 2 seconds.

Note) The temperature sensor output is fixed to 7 seconds.

Response time	Applicable model	
	Integrated display Series PF3W7	Remote monitor unit Series PF3W3
0.5 seconds	●	—
1 second	●	●
2 seconds	●	●

Selection of display on sub screen

The display on the sub screen in measuring mode can be set.

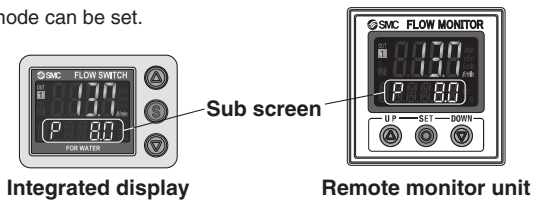

Set value display	Accumulated value display	Peak value display	Bottom value display
Displays the set value. (The set value of OUT2 cannot be displayed.) 	Displays the accumulated value. (The accumulated value of OUT2 cannot be displayed.) 	Displays the peak value. 	Displays the bottom value.
Line name display	Fluid temperature display	OFF	
Displays the line name. (Up to 6 alphanumeric characters can be input.) 	Displays the fluid temperature. (When the temperature sensor type is selected.) 	Displays nothing. 	

* The above are examples of integrated displays. (Same as remote monitor unit)

Power saving mode

The display can be turned off to reduce the power consumption. In power saving mode, decimal points blink on the main screen. If any button is pressed during power saving mode, the display is recovered for 30 seconds to check the flow, etc.

Setting of secret code

Users can select whether a secret code must be entered to release key lock. At the time of shipment from the factory, it is set such that the secret code is not required.

External input function

This function can be used when external input is available. The accumulated value, peak value, and bottom value can be reset by remote control.

Accumulated flow external reset:

This function resets the accumulated value to "0" when an input signal is applied.

In accumulated increment mode, the value will be zero when reset, and the accumulated value will increase from zero.

In accumulated decrement mode, the value will be the set value when reset, and the accumulated value will decrease from the set value.

* When the accumulated value is memorised, every time the accumulated value external reset is activated, the memory element (EEPROM) will be accessed. Take into consideration the maximum number of times the memory element can be accessed, 1 million times. The total of external input times and accumulated value memorising time interval should not exceed 1 million times.

Peak and bottom reset: Peak and bottom values are reset.

Forced output function

Output is turned ON/OFF compulsorily when starting the system or during maintenance. This enables confirmation of the wiring and prevents system errors due to unexpected output.

For the analogue output type, the output will be 5 V or 20 mA for ON and 1 V or 4 mA for OFF.

* Also, the increase or decrease of the flow and temperature will not change the on/off status of the output while the forced output function is activated.

Accumulated value hold function

Accumulated value can be saved on the unit even when the power supply is turned off.

The accumulated value is memorised every 2 or 5 minutes during measurement, and continues from the last memorised value when the power supply is turned on again.

The lifetime of the memory element is 1 million access cycles. Take this into consideration before using this function.

Peak/Bottom value indication

The maximum (minimum) flow is detected and updated from when the power supply is turned on. In peak (bottom) value indication mode, this maximum (minimum) flow is displayed.

Keylock function

Prevents operation errors such as accidentally changing setting values.

■ **Analogue output free range function**

Flow rate value that generates an output of 5 V or 20 mA can be changed. (This function is not available for the analogue output to the temperature.) This function is available if the analogue output type is used. The value can be changed within 10% of the maximum rated flow to the maximum display flow range.

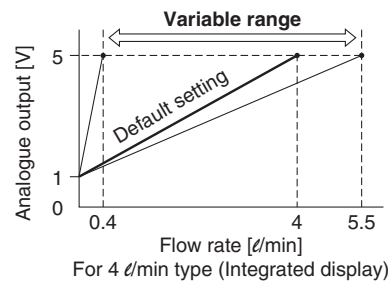

■ **Copy function (Remote monitor unit/Series PF3W3)**

The settings of the master sensor (source of copy) can be copied to the slave sensors, reducing setting labour and minimising risk of mistakes in setting.

Can copy to up to 10 switches simultaneously.
(Maximum transmission distance 4 m)

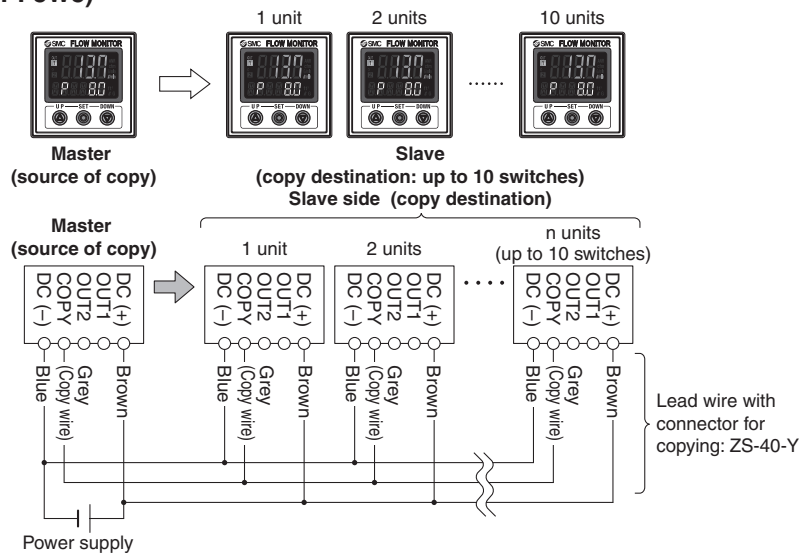

■ **Error indication function**

When a failure or error arises, the location and contents are displayed.

Indication	Description	Contents	Action	Applicable model	
				Integrated display Series PF3W7	Remote monitor unit Series PF3W3
Er1	OUT1 over current error	Load current of 80 mA or more is applied to the switch output (OUT1).	Eliminate the cause of the over current by turning off the power supply, and then turn on it again.	●	●
Er2	OUT2 over current error	Load current of 80 mA or more is applied to the switch output (OUT2).		●	●
HHH	Excessive instantaneous flow rate	Flow exceeds the upper limit of indicated flow rate range (rated flow x approx. 1.4).	Decrease the flow.	●	●
LLL	Unconnected sensor error	Remote sensor unit is not connected to the monitor unit. Or, sensor output is less than 0.6 V.	Connect the sensor or check the sensor output voltage.	—	●
9999999999 (alternately displays [999] and [999999])	Excessive accumulated flow	Flow exceeds the accumulated flow range. (Decimal points start blinking due to the flow range.)	Reset the accumulated flow value. (This error does not matter when the accumulated flow is not used.)	●	●
cHHH	Over upper limit of temperature	Fluid temperature exceeds 110°C.	Lower the fluid temperature.	●	●
cLLL	Under lower limit of temperature	Fluid temperature is under -10°C.	Raise the fluid temperature.	●	●
	Unconnected temperature sensor error	Temperature sensor output wire is not connected.	Connect the temperature output wire.	—	●
	Temperature sensor failure	If the above actions to correct the lower limit of fluid temperature and unconnected sensor are taken and error message still appears, the temperature sensor of the remote sensor unit may be damaged.	Please contact SMC for investigation.	—	●
Er0	System error	Internal data error	Turn off the power supply and then turn on it again. If the failure cannot be solved, please contact SMC for investigation.	●	●
Er4				●	●
Er6				●	●
Er8				●	●
Er12	Temperature sensor failure	Temperature sensor may be damaged.		●	—

If the failure cannot be solved after the above instructions are performed, please contact SMC for investigation.

Function Details 2

Remote Sensor Unit (Series PF3W5)

■ POWER indicator function

It is possible to check whether power supply is reaching the product. When power is supplied to the product, the indicator lights up green.



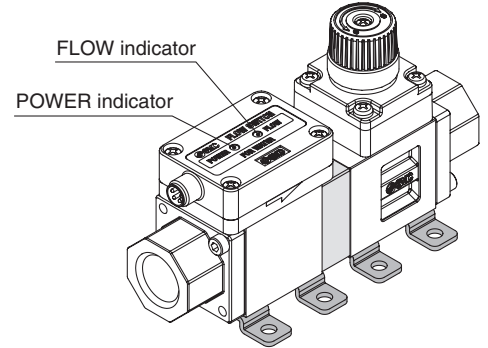

■ FLOW indicator function

Status of the flow rate can be checked visually. When the flow rate increases, the green lamp blinks faster. When below the measurable lower limit of flow rate, the lamp turns off, when above the measurable upper limit of flow rate, red lamp turns on.



■ Error indication function

When a failure or error arises, the location and contents are displayed.

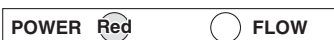
LED display	Description	Contents	Action
 POWER indicator: Green ON FLOW indicator: Red ON	Over upper limit of flow rate	Flow is approximately 110% or more of the rated flow.	Decrease the flow.
 POWER indicator: Blinking red	Temperature measurement range error	Fluid temperature is either below -10°C or above 110°C .	Adjust the fluid temperature within the measurable temperature range.
 POWER indicator: Blinking red FLOW indicator: Red ON	Over upper limit of flow rate and temperature measurement range error	Refer to above.	Refer to above.
LED display	Description	Contents	Action
 POWER indicator: Red ON FLOW indicator: Red ON	System error	Internal data error or other errors occur.	Turn off the power supply and then turn on it again. If the failure cannot be solved, please contact SMC for investigation.
 POWER indicator: Red ON FLOW indicator: Blinking red			
 POWER indicator: Red ON FLOW indicator: OFF		Temperature sensor may be damaged.	

If the failure cannot be solved after the above actions are performed, please contact SMC for investigation.



Applicable Fluids

Material and Fluid Compatibility Check List (Guide)

Chemical	Compatibility
Ammonium hydroxide Temperature 40°C or less	×
Isobutyl alcohol Temperature 40°C or less	× Note 3)
Isopropyl alcohol Temperature 40°C or less	○ Note 1), 2)
Hydrochloric acid Concentration 30% or less	○ Note 2)
Hydrogen peroxide Concentration 5% or less, Temperature 50°C or less	○
Nitric acid (except fuming nitric acid) Concentration 10% or less, Temperature 40°C or less	○ Note 2)
Deionized water	○
Sodium hydroxide (caustic soda) Concentration 50% or less	× Note 3)
Ultrapure water	○
Sulfuric acid (except fuming sulfuric acid) Concentration 30% or less	○
Phosphoric acid Concentration 50% or less	○



The material and fluid compatibility check list provides reference values as a guide only, therefore we do not guarantee the application to our product.

Note 1) Since static electricity may be generated, implement suitable countermeasures.

Note 2) Fluid may pass through. Fluid that has passed through may have an impact on components made of different materials.

Note 3) Karman vortex measurement cannot be carried out due to high viscosity.

• SMC is not responsible for its accuracy and any damage happened because of this data.

Table symbols

- : Can be used
- : Can be used under certain conditions
- × : Cannot be used



Series PF3W

Specific Product Precautions 1

Be sure to read before handling.

Refer to back cover for Safety Instructions, "Handling Precautions for SMC Products" (M-E03-3) and the Operation Manual for Flow Switch Precautions. Please download it via our website. <http://www.smcworld.com>

Design/Selection

Warning

1. Since the type of fluid varies depending on the product, be sure to verify the specifications.

The switches do not have an explosion proof rating. To prevent a possible fire hazard, do not use with flammable gases or fluids.

2. Design the system so that the fluid always fills the detection passage.

Especially for vertical mounting, introduce the fluid from the bottom to the top. If the flow goes downwards, air bubbles in the fluid will not be able to get out, causing malfunction. (There should not be a problem as long as the fluid passage is completely filled with water.)

Caution

1. Use the following UL approved products for DC power supply combinations.

A circuit (class 2 circuit) with maximum 30 Vrms (42.4 V peak) or less, and a power supply consisting of a class 2 power supply unit conforming to UL1310, or a class 2 transformer conforming to UL1585.

Mounting

Caution

1. Apply a wrench only to the metal part of the piping when installing the flow switch onto the system piping.

Do not apply the wrench to any part other than the piping attachment, or the switch may be damaged. Pay attention so that the wrench does not hit the M8 connector. This will damage the connector.

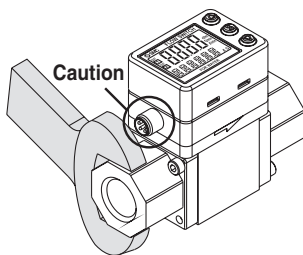

2. Avoid piping in which the piping size of the IN side of the switch changes suddenly.

When abruptly reducing the size of piping or when there is a restrictor such as a valve on the IN side, the pressure distribution in the piping changes and makes accurate measurement impossible. Therefore, flow restriction measures such as these should be implemented on the OUT side of the switch.

Also, leaving the OUT side open or bringing about excessive flow volume will increase the risk of cavitation and may make accurate measurement impossible. Increasing the fluid pressure is one means of reducing cavitation. Try a procedure such as mounting a restrictor on the OUT side of the switch. Ensure that there is no malfunction before usage. If the orifice of the OUT side is fully closed to operate the pump, the switch may malfunction due to the effect of the pulsation (pressure fluctuation). Ensure that there is no malfunction before usage.

Handling

Warning

1. When running high temperature fluid, the product will also become hot. Avoid touching the product directly as this may cause a burn.
2. The product is a flow meter using Karman vortex. The flow meter using Karman vortex has lower output frequency at excess flow state. Do not use the product within the excess flow area in the chart below.

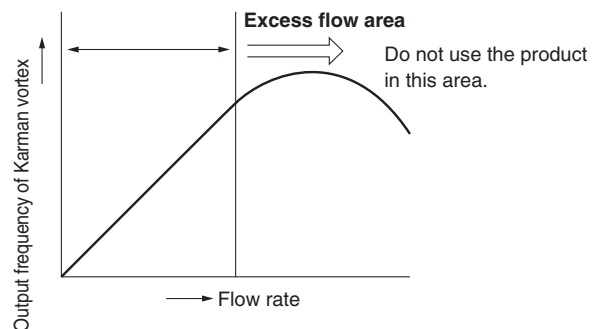

Handling of Flow Adjustment Valve

Caution

1. When adjusting the flow rate with the flow adjustment valve, do not apply excessive force to rotate it. Otherwise, this can damage the valve mechanism.
2. When fixing the valve of the flow adjustment valve, do not apply excessive force to rotate the lock ring. Otherwise, this can damage the valve mechanism.
3. After adjusting the flow rate, confirm that there is no water leakage.

After adjusting the flow rate, water leakage may occur due to the stability of the seal in the valve.

If water leakage occurs, open and close the valve several times to readjust it, and confirm that there is no water leakage.

4. The flow adjustment valve of this product is not suitable for applications which require constant adjustment of flow rate.

Fluid leakage may be generated when the internal seal reaches the end of its life due to wearing. Therefore, take measures to protect peripheral equipment, ensure maintenance space and pay attention to the piping design.

5. The flow adjustment valve of this product is not suitable for applications which require reducing the flow rate to zero completely. If it is necessary to reduce the flow rate to zero completely, separately install a stop valve, etc.

6. Do not lift it by gripping the knob of the flow adjustment valve. Hold the body when handling to avoid damaging the product.

7. If running high temperature fluid, the flow adjustment valve will also become hot, which leads to a burn. Therefore, use the flow adjustment valve with special care.



Series PF3W

Specific Product Precautions 2

Be sure to read before handling.

Refer to back cover for Safety Instructions, “Handling Precautions for SMC Products” (M-E03-3) and the Operation Manual for Flow Switch Precautions. Please download it via our website. <http://www.smcworld.com>

Operating Environment

Warning

- 1. Never use in the presence of explosive gases.**
The switches do not have an explosion proof rating. Never use in the presence of an explosive gas as this may cause a serious explosion.
- 2. Use the switch within the specified fluid and ambient temperature range.**
The fluid temperature range is 0 to 90°C and ambient temperature range is 0 to 50°C. Take measures to prevent the fluid from freezing, since this may damage the switch and lead to a malfunction. Never use the switch in an environment where there are drastic temperature changes even when these temperatures are within the specification.
- 3. If the temperature of the fluid is lower than the ambient temperature, condensation will be generated which may damage the product or cause malfunction.**
Do not install the product upside down or vertically. Water droplets may cause damage earlier.

PVC Piping

Caution

- 1. PVC fitting (union)**
The PVC fitting (union) must be mounted and joined by an engineer with sufficient knowledge.
Be sure to confirm that there is no leakage from the fitting after mounting and joining. If it is mounted and joined by a person who does not have sufficient knowledge and skills, it may lead to failure such as leakage.
- 2. When selecting adhesive for the PVC fitting (union), confirm that its heat resistance and endurance are compatible with the operating temperature of the fluids used. Otherwise, this may cause leakage and damage.**
- 3. Do not apply excessive force to the PVC piping. This may cause damage.**
- 4. When the PVC piping type is used, the higher the fluid temperature, the lower the proof pressure will be. Therefore, adjust the water hammer pressure carefully so that it does not exceed the proof pressure.**

Maintenance

Warning

- 1. Take precautions when using the switch for an interlock circuit.**
When a pressure switch is used for the interlock circuit, devise a multiple interlock system to prevent trouble or malfunction, and verify the operation of the switch and interlock function on a regular basis.

Measured Fluid

Warning

- 1. Check regulators and flow adjustment valves before introducing the fluid.**
If pressure or flow rate beyond the specified range are applied to the switch, the sensor unit may be damaged.
- 2. The fluids applicable for the switch are water and ethylene glycol aqueous solution (with viscosity of 3 mPa·s [3 cP] or less).**
- 3. Install a filter on the IN side when there is a possibility of foreign matter being mixed with the fluid.**
If foreign matter adheres to the switch's vortex generator or vortex counter, accurate measurement will no longer be possible. We recommend a filter with filtration of approx. 40 mesh.

Others

Warning

- 1. After the power is turned on, the switch's output remains off while a message is displayed (for approx. 3 seconds). Therefore, start the measurement after a value is displayed.**
- 2. Perform settings after stopping control systems.**
- 3. Do not apply excessive rotational force to the monitor unit.**
The monitor of the integrated display type is rotatable. It can rotate by 90° counterclockwise and 225° clockwise, in increments of 45°. The stopper may be damaged if the monitor unit is turned with excessive force.

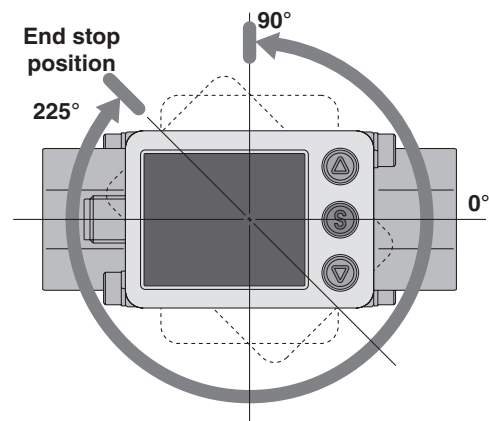



Series PF3W

Specific Product Precautions 3

Be sure to read before handling.

Refer to back cover for Safety Instructions, “Handling Precautions for SMC Products” (M-E03-3) and the Operation Manual for Flow Switch Precautions. Please download it via our website. <http://www.smcworld.com>

Set Flow Range and Rated Flow Range

Caution

Set the flow within the rated flow range.



The set flow range is the range of flow rate that is possible in setting.

The rated flow range is the range that satisfies the sensor’s specifications (accuracy, etc.).

Although it is possible to set a value outside the rated flow range, the specifications will not be guaranteed even if the value stays within the set flow range.

Sensor	Flow range						
	0.5 ℓ/min	2 ℓ/min	5 ℓ/min	20 ℓ/min	40 ℓ/min	100 ℓ/min	140 ℓ/min
PF3W704 PF3W504			4 ℓ/min				
	0.5 ℓ/min		5.5 ℓ/min				
	0.35 ℓ/min		5.5 ℓ/min				
	0.35 ℓ/min						
PF3W720 PF3W520		2 ℓ/min	16 ℓ/min				
	1.7 ℓ/min		22 ℓ/min				
	1.7 ℓ/min		22 ℓ/min				
PF3W740 PF3W540			5 ℓ/min		40 ℓ/min		
		3.5 ℓ/min			55 ℓ/min		
		3.5 ℓ/min			55 ℓ/min		
PF3W711 PF3W511			10 ℓ/min			100 ℓ/min	
			7 ℓ/min				140 ℓ/min
			7 ℓ/min				140 ℓ/min

* In the case of the PF3W5 series, the displayable and settable ranges are the same as the PF3W3 series flow monitor.

 Rated flow range
 Display flow range
 Set flow range



Series PF3W

Specific Product Precautions 4

Be sure to read before handling.

Refer to back cover for Safety Instructions, "Handling Precautions for SMC Products" (M-E03-3) and the Operation Manual for Flow Switch Precautions. Please download it via our website. <http://www.smcworld.com>

■ Digital Flow Monitor/Series PF3W3

Mounting

⚠ Caution

1. The front face of the panel mount conforms to IP65, however there is a possibility of liquid infiltration if the panel mount adapter is not installed securely and properly. Securely fix the adapter with screws as shown below. Screw tightening torque differs depending on the panel material used, so it is not possible to give a specific recommended value. Mount so that the product does not damage.

Tighten screws 1/4 to 1/2 turn after the heads are flush with the panel.

Front protective cover + Panel mount adapter

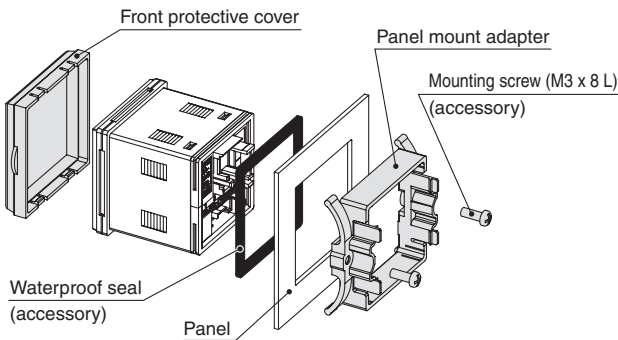

Wiring

⚠ Caution

1. Connecting sensor lead wire and connector

- Cut the sensor lead wire as shown below.
- Insert each lead wire into the corresponding connector number by following the chart provided below.

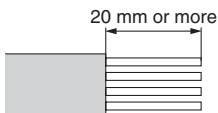

Connector no.	Lead wire colour
1	Brown (DC+)
2	White (Temperature sensor 1 to 5 V input)
3	Blue (DC-)
4	Black (Flow rate sensor 1 to 5 V input)

- Make sure that the numbers on the connector and the wire colours match. After verifying that the wires are fully inserted, temporarily hold A down by hand.
- Using pliers, press the center of A straight down.
- Note that that connector cannot be taken apart for reuse once it is crimped. Use a new sensor connector if wiring or lead wire insertion is done incorrectly.

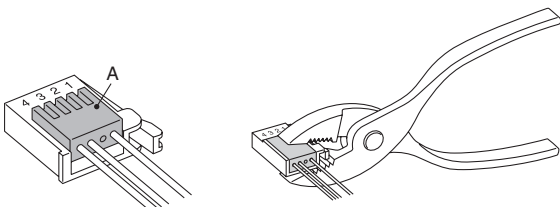

Wiring

⚠ Caution

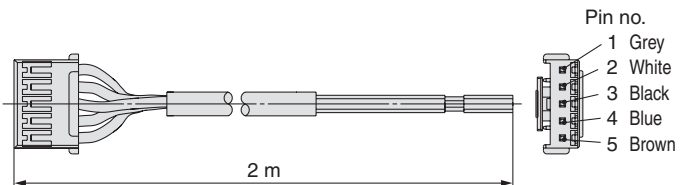
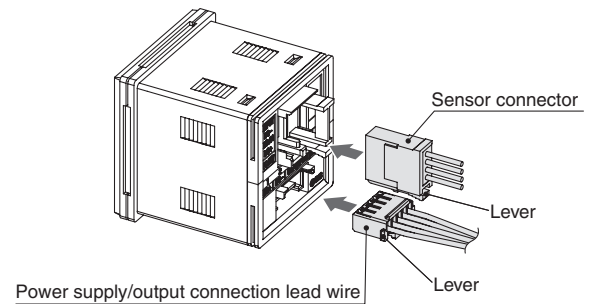
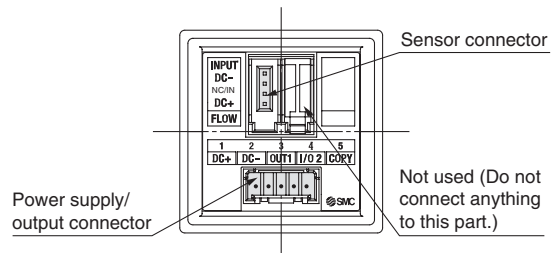

2. Inserting/detaching of sensor connector, power supply/output connector

- Insert each connector straightforwardly until it clicks and locks onto the body.
- To remove the connector, pull it straight out while pushing the lever with your thumb.



Safety Instructions

These safety instructions are intended to prevent hazardous situations and/or equipment damage. These instructions indicate the level of potential hazard with the labels of “**Caution**,” “**Warning**” or “**Danger**.” They are all important notes for safety and must be followed in addition to International Standards (ISO/IEC)*1, and other safety regulations.

-  **Caution:** **Caution** indicates a hazard with a low level of risk which, if not avoided, could result in minor or moderate injury.
-  **Warning:** **Warning** indicates a hazard with a medium level of risk which, if not avoided, could result in death or serious injury.
-  **Danger:** **Danger** indicates a hazard with a high level of risk which, if not avoided, will result in death or serious injury.

- *1) ISO 4414: Pneumatic fluid power – General rules relating to systems.
ISO 4413: Hydraulic fluid power – General rules relating to systems.
IEC 60204-1: Safety of machinery – Electrical equipment of machines.
(Part 1: General requirements)
- ISO 10218-1: Manipulating industrial robots - Safety.
etc.

Warning

1. The compatibility of the product is the responsibility of the person who designs the equipment or decides its specifications.

Since the product specified here is used under various operating conditions, its compatibility with specific equipment must be decided by the person who designs the equipment or decides its specifications based on necessary analysis and test results. The expected performance and safety assurance of the equipment will be the responsibility of the person who has determined its compatibility with the product. This person should also continuously review all specifications of the product referring to its latest catalogue information, with a view to giving due consideration to any possibility of equipment failure when configuring the equipment.

2. Only personnel with appropriate training should operate machinery and equipment.

The product specified here may become unsafe if handled incorrectly. The assembly, operation and maintenance of machines or equipment including our products must be performed by an operator who is appropriately trained and experienced.

3. Do not service or attempt to remove product and machinery/equipment until safety is confirmed.

1. The inspection and maintenance of machinery/equipment should only be performed after measures to prevent falling or runaway of the driven objects have been confirmed.
2. When the product is to be removed, confirm that the safety measures as mentioned above are implemented and the power from any appropriate source is cut, and read and understand the specific product precautions of all relevant products carefully.
3. Before machinery/equipment is restarted, take measures to prevent unexpected operation and malfunction.

4. Contact SMC beforehand and take special consideration of safety measures if the product is to be used in any of the following conditions.

1. Conditions and environments outside of the given specifications, or use outdoors or in a place exposed to direct sunlight.
2. Installation on equipment in conjunction with atomic energy, railways, air navigation, space, shipping, vehicles, military, medical treatment, combustion and recreation, or equipment in contact with food and beverages, emergency stop circuits, clutch and brake circuits in press applications, safety equipment or other applications unsuitable for the standard specifications described in the product catalogue.
3. An application which could have negative effects on people, property, or animals requiring special safety analysis.
4. Use in an interlock circuit, which requires the provision of double interlock for possible failure by using a mechanical protective function, and periodical checks to confirm proper operation.

Caution

1. The product is provided for use in manufacturing industries.

The product herein described is basically provided for peaceful use in manufacturing industries.

If considering using the product in other industries, consult SMC beforehand and exchange specifications or a contract if necessary.

If anything is unclear, contact your nearest sales branch.

Limited warranty and Disclaimer/ Compliance Requirements

The product used is subject to the following “Limited warranty and Disclaimer” and “Compliance Requirements”.

Read and accept them before using the product.

Limited warranty and Disclaimer

1. The warranty period of the product is 1 year in service or 1.5 years after the product is delivered.*2)

Also, the product may have specified durability, running distance or replacement parts. Please consult your nearest sales branch.

2. For any failure or damage reported within the warranty period which is clearly our responsibility, a replacement product or necessary parts will be provided.

This limited warranty applies only to our product independently, and not to any other damage incurred due to the failure of the product.

3. Prior to using SMC products, please read and understand the warranty terms and disclaimers noted in the specified catalogue for the particular products.

*2) Vacuum pads are excluded from this 1 year warranty.

A vacuum pad is a consumable part, so it is warranted for a year after it is delivered.

Also, even within the warranty period, the wear of a product due to the use of the vacuum pad or failure due to the deterioration of rubber material are not covered by the limited warranty.

Compliance Requirements

1. The use of SMC products with production equipment for the manufacture of weapons of mass destruction (WMD) or any other weapon is strictly prohibited.

2. The exports of SMC products or technology from one country to another are governed by the relevant security laws and regulations of the countries involved in the transaction. Prior to the shipment of a SMC product to another country, assure that all local rules governing that export are known and followed.

Safety Instructions

Be sure to read “Handling Precautions for SMC Products” (M-E03-3) before using.

SMC Corporation (Europe)

Austria	☎+43 (0)2262622800	www.smc.at	office@smc.at
Belgium	☎+32 (0)33551464	www.smc-pneumatics.be	info@smc-pneumatics.be
Bulgaria	☎+359 (0)2807670	www.smc.bg	office@smc.bg
Croatia	☎+385 (0)13707288	www.smc.hr	office@smc.hr
Czech Republic	☎+420 541424611	www.smc.cz	office@smc.cz
Denmark	☎+45 70252900	www.smc.dk.com	smc@smc.dk.com
Estonia	☎+372 6510370	www.smc-pneumatics.ee	smc@smc-pneumatics.ee
Finland	☎+358 207513513	www.smc.fi	smcffi@smc.fi
France	☎+33 (0)164761000	www.smc-france.fr	promotion@smc-france.fr
Germany	☎+49 (0)61034020	www.smc-pneumatik.de	info@smc-pneumatik.de
Greece	☎+30 210 2717265	www.smc-hellas.gr	sales@smc-hellas.gr
Hungary	☎+36 23511390	www.smc.hu	office@smc.hu
Ireland	☎+353 (0)14039000	www.smc-pneumatics.ie	sales@smc-pneumatics.ie
Italy	☎+39 0292711	www.smc-italia.it	mailbox@smc-italia.it
Latvia	☎+371 67817700	www.smc.lv	info@smc.lv

Lithuania	☎+370 5 2308118	www.smclt.lt	info@smclt.lt
Netherlands	☎+31 (0)205318888	www.smc-pneumatics.nl	info@smc-pneumatics.nl
Norway	☎+47 67129020	www.smc-norge.no	post@smc-norge.no
Poland	☎+48 (0)222119616	www.smc.pl	office@smc.pl
Portugal	☎+351 226166570	www.smc.eu	postpt@smc.smces.es
Romania	☎+40 213205111	www.smcromania.ro	smcromania@smcromania.ro
Russia	☎+7 8127185445	www.smc-pneumatik.ru	info@smc-pneumatik.ru
Slovakia	☎+421 (0)413213212	www.smc.sk	office@smc.sk
Slovenia	☎+386 (0)73885412	www.smc.si	office@smc.si
Spain	☎+34 945184100	www.smc.eu	post@smc.smces.es
Sweden	☎+46 (0)86031200	www.smc.nu	post@smc.nu
Switzerland	☎+41 (0)523963131	www.smc.ch	info@smc.ch
Turkey	☎+90 212 489 0 440	www.smc-pneumatik.com.tr	info@smc-pneumatik.com.tr
UK	☎+44 (0)845 121 5122	www.smc-pneumatics.co.uk	sales@smc-pneumatics.co.uk