



**Innovation has a
brand new color.**



**Introducing the new
CV-5200 Connection Validation™
Soldering Station**

**Metcal is raising the bar with a
technology that will change hand
soldering forever.**

Metcal soldering stations have led the way with SmartHeat® technology for 35 years. SmartHeat senses the thermal load and instantly delivers Power on Demand directly to the joint. The embedded, self-regulating heater delivers the right amount of power based on the requirements of the solder joint. This provides a fast, safe and repeatable process with no calibration required.

**Currently, the industry standard relies
on a visual inspection of the solder
joint. Metcal has developed a better
way...
Introducing Connection Validation.**



CV-5200 Series

Connection Validation™ Soldering Station



The intermetallic compound thickness is critical in the formation of a solder joint. Connection Validation (CV) evaluates the quality of the solder joint by calculating the intermetallic compound formation and provides closed loop feedback to the operator.

CV provides feedback to the operator via the LED light ring integrated in the hand-piece. It takes the risk associated with the variables involved in the soldering activity and removes the success and failure determination of a good solder joint out of the hands of the operator.

CV complements the skill of the operator to judge the quality of a solder joint by introducing an objective method of evaluating solder joint quality. This systemic and objective approach provides repeatability and a measureable standard to the soldering process.

Features and Benefits

- SmartHeat Power on Demand Technology
- Patented Connection Validation IMC Formation Technology
- 2.8" color touchscreen with bold graphics
- Communications Port for process traceability data and firmware graphics
- Integrated Net Power Meter and power graph
 - With optional precise tip temperature display
- Patented Chip-in-Cartridge technology
 - Closed loop bi-directional communication
 - Stores and records cartridge attributes
 - Provides traceability information
 - Protects power supply from non-conforming cartridges
 - Backwards compatible with MX series power supplies
- Password protection



LED equipped hand piece signals to operator when a good solder joint is formed.



Tip temperature displayed on large color screen.

System Configuration

The CV-5210 soldering station includes:

- CV Power supply
- CV-H1-AV: Advanced hand-piece with integrated LED light*
- MX-W1AV: TipSaver Workstand*

Additional system configurations will be available soon.

**Can be ordered separately.*

Technical Specifications

CV-5200 Connection Validation Power Supply	
Ambient Operating Temp.	10 to 40 °C
Max. Enclosure Temp.	55°C
Input Line Voltage	100 – 240 VAC, grounded circuit
Input Line Frequency	50/60 Hz
Rated Power Consumption	125W
Output Power	80W max.
Output Frequency	13.56 MHz
Heating Method	Induction
Display	2.8" Color TFT LCD Display
Resolution	320*240 RGB
Size	2.8" Diagonal
Active Area	43.20 x 57.60 mm
Connections	Single Port
Communications	USB
Power Supply Dim. w x d x h (mm)	121 x 130 x 235
Power Supply Weight (kg)	3.35
Certification / Marking	CE TUV
Tip-to- Ground Potential	<2mV
Tip-to-Ground Resistance	<2ohms
Idle Temperature Stability	1.1°C in still air
Tip Temperature Accuracy	Meets or exceeds IPC J-STD-001 Standard
Hand-piece cable length	L=183cm (72"), burn proof, ESD safe
Hand-piece connectors	
RF Connector	F type power connector
LED Power Connector	6 pin DIN
Operation	2 single port or dynamic dual simultaneous
Firmware upgrade	Via USB port and appropriate software with compatible computer and cables.

New Connection Validation Monitoring Software



Introducing the All-New CV Monitoring Software

Improve your solder process traceability and create a performance baseline using CV's intelligent cartridges plus CV-5000 Monitor software. Using our Connection Validation patented technology, CV Monitor software allows you to capture solder process information over time for each joint when attached to the communication port.

Now that you have a baseline, you can quickly analyze your soldering performance, identify changes in your solder conditions, and make changes to your process. Download the free CV-5000 Monitor software and start monitoring your process.

**Metcal Exclusive*

You'll get:

- Power demand
- Tip temperature
- Solder time
- Intermetallic Compound Formation (IMC Formation)*

Download the free software to get started.
www.Metcal.com



CV-5200 Series

Connection Validation™ Soldering Station



New Cartridge Smart Numbering Scheme

With the introduction of Connection Validation, Metcal is migrating to a new smart numbering convention that is designed to assist the operator or the process engineer in the selection of the correct cartridge for the application.

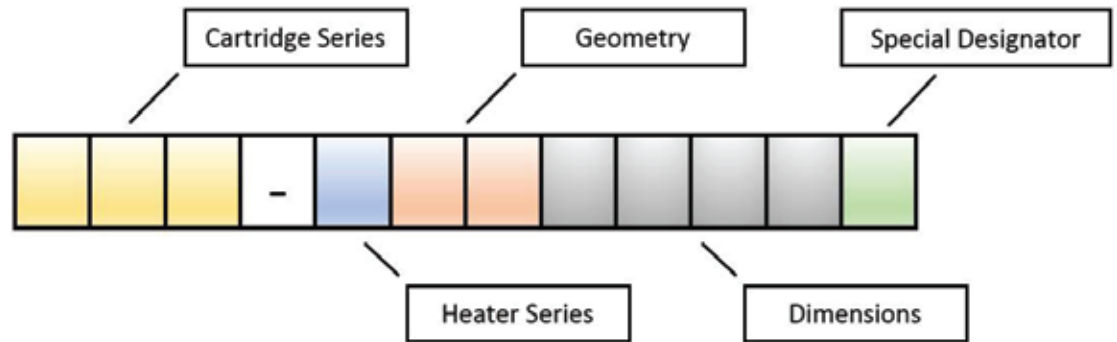

Cartridge & Heater Series Legend

Cartridge Series

- CVC – Connection Validation Cartridges, Connection Validation enabled
- SMC – Surface Mount Cartridges
- New cartridge series to be added soon

Heater Series – represented by the x in the part number.

- 5-500 series heaters
- 6-600 series heaters
- 7-700 series heaters
- 8-800 series heaters
- 9-900 series heaters

Dimensions

Four digit numerical value, which represents the key dimension of the geometry.

Special Designator

Provides an additional level of identification to the cartridge to better identify any unique attributes

A	Access	additional length in one axis, >10mm
D	Deep Taper	
H	High Mass	Similar in design to another tip geometry with increased thermal mass
J	Reach with Taper	additional length >10mm with a change in axis, Taper
L	Long Life	increased tip plating
N	Non-Wetting	1 or more surfaces that are non-wetting
P	Power	reduced length in one-axis, <6.5mm
Q	Square	Square end feature for Flat Blade geometry
R	Reach	additional length >10mm with a change in axis
S	Standard	
T	Taper	Taper with Step
U	Round	Round end feature for Flat Blade geometry
V	Concave	
W	Enlarged Wetting Area	
X	Power & Long Life	reduced length in one-axis, <6.5mm, increased tip plating

Geometry

BL	Blade	KN	Knife
BV	Bevel	MH	Mini-Hoof
CH	Chisel	QD	Quad
CN	Conical	SC	Slotted Cylindrical
CP	Hollow Cup	SH	Shield
TN	Tunnel	SL	Slot
HF	Hoof	WV	Wave
HK	Hook	FB	Flat Blade
HP	Hot Plate	VC	V-Groove Chisel
HS	Heat Stake	PC	Pin Connector
LG	Long Groove	SK	Socket

Note: STTC/SMTC cartridges will not work on CV-5200 series systems.

CV-5200 Series

Connection Validation™ Soldering Station



Cartridge Part Number Cross Reference Table

Current Part Number	New Part Number	Description
STTC-x46	CVC-xBV6005A	CARTRIDGE, BEVEL, 0.5MM X 14MM LG, 60DEG
STTC-x47P	CVC-xBV6018P	CARTRIDGE, BEVEL, 1.8MM X 6MM LG, 60DEG
STTC-x47	CVC-xBV6018R	CARTRIDGE, BEVEL, 1.8MM X 14MM LG, 70DEG
STTC-x25P	CVC-xCH0010P	CARTRIDGE, CHISEL, 1MM X 6MM LG, 35DEG
STTC-x25	CVC-xCH0010S	CARTRIDGE, CHISEL, 1MM, 30DEG
STTC-x38P	CVC-xCH0014P	CARTRIDGE, CHISEL, 1.4MM X 6MM LG, 35DEG
STTC-x99	CVC-xCH0015R	CARTRIDGE, CHISEL, REACH, 1.4MM X 12MM LG, 30DEG
STTC-x38	CVC-xCH0014S	CARTRIDGE, CHISEL, 1.4MM X 9.9MM LG, 30DEG
STTC-x42	CVC-xCH0018A	CARTRIDGE, CHISEL, ACCESS, 1.8MM X 15MM LG, 60DEG
STTC-x37LL	CVC-xCH0018L	CARTRIDGE, CHISEL, 1.8MM X 10MM LG, 30DEG, LL
STTC-x37P	CVC-xCH0018P	CARTRIDGE, CHISEL, 1.8MM X 6MM LG, 35DEG
STTC-x98	CVC-xCH0018R	CARTRIDGE, CHISEL, REACH, 1.8MM X 10MM LG, 30DEG
STTC-x37	CVC-xCH0018S	CARTRIDGE, CHISEL, 1.8MM X 10MM LG, 30DEG
STTC-x36P	CVC-xCH0025P	CARTRIDGE, CHISEL, 2.5MM X 6MM LG, 30DEG
STTC-x36	CVC-xCH0025S	CARTRIDGE, CHISEL, 2.5MM X 10MM LG, 30DEG
STTC-x13	CVC-xCH0030S	CARTRIDGE, CHISEL, 3MM X 5MM LG, 90DEG
STTC-x03	CVC-xCH0034S	CARTRIDGE, CHISEL 3MM X 9MM LG
STTC-x65	CVC-xCH0050A	CARTRIDGE, CHISEL, 5MM X 12MM LG, 22DEG
STTC-x17	CVC-xCH0050S	CARTRIDGE, CHISEL, LARGE, 5MM X 8MM LG, 30DEG
STTC-x20	CVC-xCH2238A	CARTRIDGE, CHISEL, 3.8MM X 22MM LG, 12DEG
STTC-x90	CVC-xCN0003A	CARTRIDGE, CONICAL, 0.25MM X 13.5MM LG
STTC-x45P	CVC-xCN0004P	CARTRIDGE, CONICAL, 0.4MM X 9MM LG
STTC-x26	CVC-xCN0004R	CARTRIDGE, CONICAL, REACH, 0.6MM X 8MM LG, 35DEG
STTC-x22	CVC-xCN1404S	CARTRIDGE, CONICAL, 0.4MM X 9MM LG
STTC-x43	CVC-xCN0005A	CARTRIDGE, CONICAL, 0.5MM X 15MM LG
STTC-x44	CVC-xCN0005R	CARTRIDGE, CONICAL, REACH, 0.5MM X 15MM LG, 30DEG
STTC-x11	CVC-xCN0005S	CARTRIDGE, CONICAL, 0.5MM X 5MM LG
STTC-x01	CVC-xCN0010A	CARTRIDGE, CONICAL, 1MM X 13MM LG
STTC-x01P	CVC-xCN0010P	CARTRIDGE, CONICAL, 1MM X 6.5MM LG
STTC-x41	CVC-xCN0013R	CARTRIDGE, CONICAL, REACH, 1.3MM X 22MM LG, 30DEG
STTC-x06	CVC-xCN1304A	CARTRIDGE, CONICAL, 0.4MM
STTC-x45	CVC-xCN1504A	CARTRIDGE, CONICAL, 0.4MM X 15MM LG
STTC-x40	CVC-xCN1604R	CARTRIDGE, CONICAL, REACH, 0.8MM X 16MM LG, 30DEG
STTC-x07	CVC-xCN1710A	CARTRIDGE, CONICAL, ACCESS, 1MM X 17MM LG
SMTC-x167	SMC-xHF6015S	CARTRIDGE, HOOF, 1.5MM X 16.5MM LG, 60 DEG
SMTC-x147	SMC-xHF6033S	CARTRIDGE, HOOF, 3.3MM X 17MM LG, 60 DEG
SMTC-x172	SMC-xHK0005S	CARTRIDGE, HOOK, LONG, 0.5MM

Note: STTC/SMTC cartridges will not work on CV-5200 series systems.

CV-5200 Series

Connection Validation™ Soldering Station



Cartridge Part Number Cross Reference Table

Old Part Number	New Part Number	Description
STTC-x05	CVC-xBV3018S	CARTRIDGE, BEVEL, 1.78MM, 30DEG
STTC-x15	CVC-xBV3018P	CARTRIDGE, BEVEL, 1.27MM, 30DEG
STTC-x24	CVC-xBV4001S	CARTRIDGE, BEVEL 1MM, 30DEG
STTC-x35	CVC-xBV6018S	CARTRIDGE, BEVEL, 1.78MM, 30DEG
STTC-x14	CVC-xCH0020S	CARTRIDGE, BEVEL, 2MM, 45DEG
STTC-x31	CVC-xCN0010S	CARTRIDGE, CONICAL, 1MM
STTC-x32	CVC-xCN1002S	CARTRIDGE, CONICAL, 1.78MM
STTC-x02	CVC-xCN1208S	CARTRIDGE, CONICAL, 1.78MM
STTC-x12	CVC-xCN4302S	CARTRIDGE, CONICAL, 2MM
STTC-x16	CVC-xCN4805S	CARTRIDGE, CONICAL, 0.5MM
STTC-x83	CVC-xLG1802A	CARTRIDGE, CONICAL, 2MM
SMTC-x60	SMC-xBL0010S	CARTRIDGE, BLADE, 10MM
SMTC-xBL150	SMC-xBL0015H	CARTRIDGE, HIGH MASS, BLADE 15MM
SMTC-x61	SMC-xBL0016S	CARTRIDGE, BLADE, 15.75MM
SMTC-x62	SMC-xBL0022S	CARTRIDGE, BLADE, 22MM
SMTC-xBL250	SMC-xBL0025H	CARTRIDGE, HIGH MASS, BLADE 25MM
SMTC-xBL350	SMC-xBL0035H	CARTRIDGE, HIGH MASS, BLADE 35MM
SMTC-x184	SMC-xHF0015V	CARTRIDGE, CONCAVE HOOF, 1.5MM
SMTC-x185	SMC-xHF0020V	CARTRIDGE, CONCAVE HOOF, 2MM
SMTC-x186	SMC-xHF0030V	CARTRIDGE, CONCAVE HOOF, 3MM
SMTC-x183	SMC-xHF3025S	CARTRIDGE, HOOF, CONCAVE, 2.5MM, BENT, 30 DEG
SMTC-x175	SMC-xHF6009S	CARTRIDGE, HOOF, 0.89MM, 60 DEG
SMTC-x174	SMC-xHF6011S	CARTRIDGE, HOOF, LONG, 1.1MM, 60 DEG
SMTC-x169	SMC-xHF6020S	CARTRIDGE, HOOF, LONG, 2MM, 60 DEG
SMTC-x170	SMC-xHF6030S	CARTRIDGE, HOOF, LONG, 3MM, 60 DEG
SMTC-x171	SMC-xHK0008S	CARTRIDGE, CONICAL, BENT, 0.76MM
SMTC-x165	SMC-xKN0025S	CARTRIDGE, KNIFE, 2.5MM
SMTC-x161	SMC-xKN0048S	CARTRIDGE, KNIFE, THIN TIN LENGTH, 4.8MM
SMTC-x173	SMC-xKN0048W	CARTRIDGE, KNIFE, WIDE TIN LENGTH, 4.8MM
STTC-x173P	SMC-xKN0050P	CARTRIDGE, KNIFE, POWER, 5MM
STTC-x173PLL	SMC-xKN0050X	CARTRIDGE, KNIFE, 5MM

CVC & SMC Cartridges are compatible with MX-500, MX-5000, MX-5200 and CV-5200 Systems – MX-RM3E, MX-H1-AV and CV-H1-AV Hand pieces

STTC & SMTC Cartridges are compatible with MX-500, MX-5000 and MX-5200 Systems – MX-RM3E and MX-H1-AV Hand pieces

Temperature	STTC/SMTC	CVC/SMC	Application
302 °C	STTC-5xx	CVC-5xxx	Temperature Sensitive
357 °C	STTC-0xx	CVC-6xxx	
412 °C	STTC-1xx	CVC-7xxx	Most Standard
468 °C	STTC-8xxV1	CVC-8xxx	Ceramic and High Thermal Demand
510 °C	STTC-8xx	CVC-9xxx	

Please note the above temperatures are the maximum temperatures of the heater. The idle temperature is dependent on the geometry of the cartridge (up to 15°C lower.)

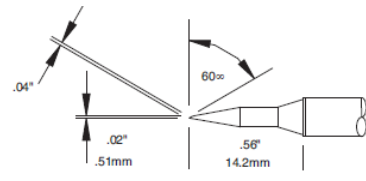
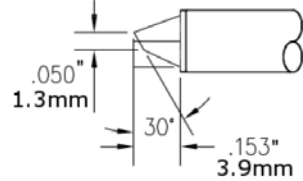
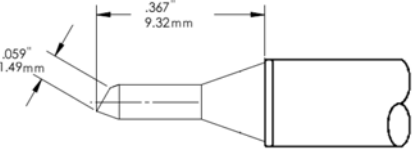
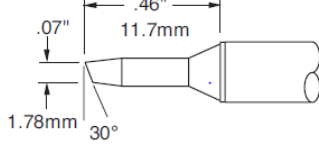
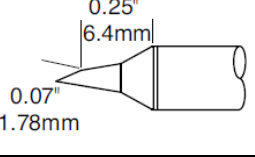
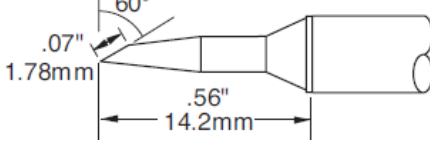
Bevel			
	CVC-5BV6005A CVC-6BV6005A CVC-7BV6005A CVC-8BV6005A CVC-9BV6005A	STTC-546 STTC-046 STTC-146 STTC-846V1 STTC-846	Long Reach Bevel 60° 0.50mm x 14.2mm (.04"x .56")
	CVC-5BV3018P CVC-6BV3018P CVC-7BV3018P CVC-8BV3018P CVC-9BV3018P	STTC-515 STTC-015 STTC-115 STTC-815V1 STTC-815	Bevel, 30° P = Optimised geometry for best thermal performance 1.3mm x 3.9mm (.05" x 0153")
	CVC-5BV4001S CVC-6BV4001S CVC-7BV4001S CVC-8BV4001S CVC-9BV4001S	STTC-524 STTC-024 STTC-124 STTC-824V1 STTC-824	Bevel 30° 1.5mm x 9.3mm (.059"x .367")
	CVC-5BV3018S CVC-6BV3018S CVC-7BV3018S CVC-8BV3018S CVC-9BV3018S	STTC-505 STTC-005 STTC-105 STTC-805V1 STTC-805	Bevel 30° 1.78mm x 11.7mm (.07"x .39")
	CVC-5BV6018P CVC-6BV6018P CVC-7BV6018P CVC-8BV6018P CVC-9BV6018P	STTC-547P STTC-047P STTC-147P STTC-847PV1 STTC-847P	Bevel 60° P = Optimised geometry for best thermal performance 1.78mm x 6.4mm (.07" x .25")
	CVC-5BV6018R CVC-6BV6018R CVC-7BV6018R CVC-8BV6018R CVC-9BV6018R	STTC-547 STTC-047 STTC-147 STTC-847V1 STTC-847	Long Reach Bevel 60° 1.78mm x 14.2mm (.07"x .56")

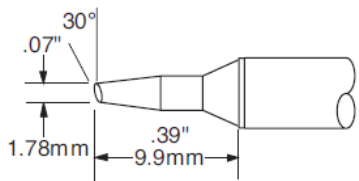
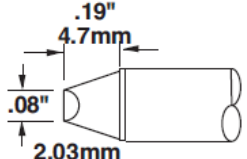
Bevel			
	CVC-5BV6018S CVC-6BV6018S CVC-7BV6018S CVC-8BV6018S CVC-9BV6018S	STTC-535 STTC-035 STTC-135 STTC-835V1 STTC-835	Bevel 30° 1.78mm x 9.9mm (.07" x .39")
	CVC-5CH0020S CVC-6CH0020S CVC-7CH0020S CVC-8CH0020S CVC-9CH0020S	STTC-514 STTC-014 STTC-114 STTC-814V1 STTC-814	Chisel, 2.0mm x 4.7mm (.08" x .19")

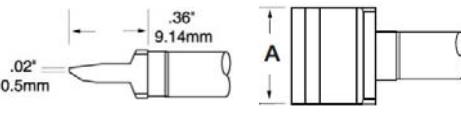
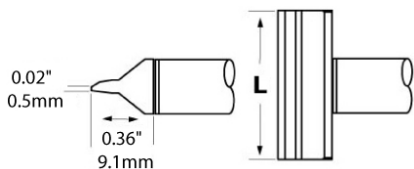
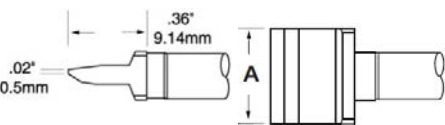
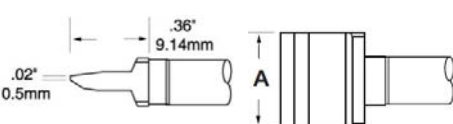
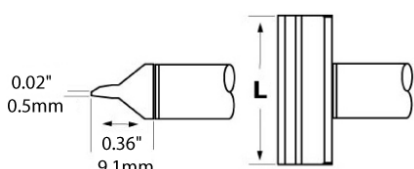
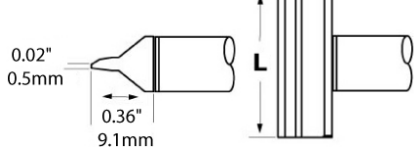
Blade for Pad Cleaning			
	SMC-5BL0010S SMC-6BL0010S SMC-7BL0010S SMC-8BL0010S SMC-9BL0010S	SMTC-560 SMTC-060 SMTC-160 SMTC-860V1 SMTC-860	Blade Long A=10mm (.40")
	SMC-5BL0015H SMC-6BL0015H SMC-7BL0015H SMC-8BL0015H SMC-9BL0015H	SMTC-5BL150 SMTC-0BL150 SMTC-1BL150 SMTC-8BL150V1 SMTC-8BL150	Blade Short L=15mm (.59")
	SMC-5BL0016S SMC-6BL0016S SMC-7BL0016S SMC-8BL0016S SMC-9BL0016S	SMTC-561 SMTC-061 SMTC-161 SMTC-861V1 SMTC-861	Blade Long A=15.75mm (.62")
	SMC-5BL0022S SMC-6BL0022S SMC-7BL0022S SMC-8BL0022S SMC-9BL0022S	SMTC-562 SMTC-062 SMTC-162 SMTC-862V1 SMTC-862	Blade Long A=22mm (.86")
	SMC-5BL0025H SMC-6BL0025H SMC-7BL0025H SMC-8BL0025H SMC-9BL0025H	SMTC-5BL250 SMTC-0BL250 SMTC-1BL250 SMTC-8BL250V1 SMTC-8BL250	Blade Long L=25mm (1")
	SMC-5BL0035H SMC-6BL0035H SMC-7BL0035H SMC-8BL0035H SMC-9BL0035H	SMTC-5BL350 SMTC-0BL350 SMTC-1BL350 SMTC-8BL350V1 SMTC-8BL350	Blade Long L=35mm (1.38")

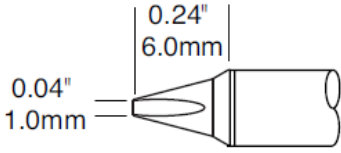
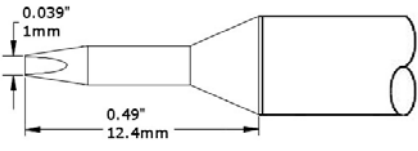
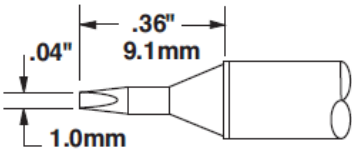
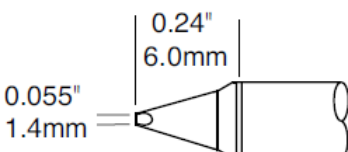
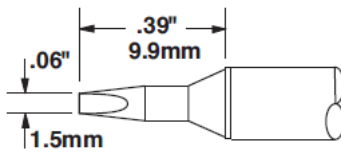
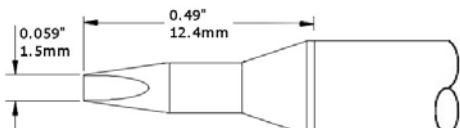
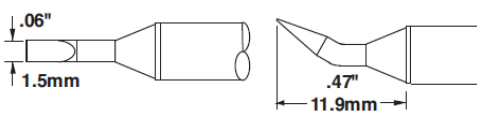
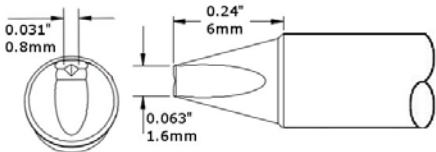
Chisel			
	CVC-5CH0010P CVC-6CH0010P CVC-7CH0010P CVC-8CH0010P CVC-9CH0010P	STTC-525P STTC-025P STTC-125P STTC-825PV1 STTC-825P	Chisel 30° P = Optimised geometry for best thermal performance 1.0mm x 6.0mm (.04" x .24")
	CVC-5CH0010A CVC-6CH0010A CVC-7CH0010A CVC-8CH0010A CVC-9CH0010A	N/A	Long Reach Chisel 30° 1.0mm x 12.4mm (.04" x .49")
	CVC-5CH0010S CVC-6CH0010S CVC-7CH0010S CVC-8CH0010S CVC-9CH0010S	STTC-525 STTC-025 STTC-125 STTC-825V1 STTC-825	Chisel 30° 1.0mm x 9.1mm (.04" x .33")
	CVC-5CH0014P CVC-6CH0014P CVC-7CH0014P CVC-8CH0014P CVC-9CH0014P	STTC-538P STTC-038P STTC-138P STTC-838PV1 STTC-838P	Chisel 30° P = Optimised geometry for best thermal performance 1.4mm x 6.0mm (.06" x .24")
	CVC-5CH0014S CVC-6CH0014S CVC-7CH0014S CVC-8CH0014S CVC-9CH0014S	STTC-538 STTC-038 STTC-138 STTC-838V1 STTC-838	Chisel 30° 1.5mm x 9.9mm (.06" x .39")
	CVC-5CH0015A CVC-6CH0015A CVC-7CH0015A CVC-8CH0015A CVC-9CH0015A	N/A	Long Reach Chisel 1.5mm x 12.4mm (.06" x .49")
	CVC-5CH0015R CVC-6CH0015R CVC-7CH0015R CVC-8CH0015R CVC-9CH0015R	STTC-599 STTC-099 STTC-199 STTC-899V1 STTC-899	Chisel Bent 30° 1.5mm x 11.9mm (.06" x .47")
	CVC-5VG0016A CVC-6VG0016A CVC-7VG0016A CVC-8VG0016A CVC-9VG0016A	N/A	V-Groove Chisel 1.6mm x 6.0mm (.06" x .24") for THT pin soldering

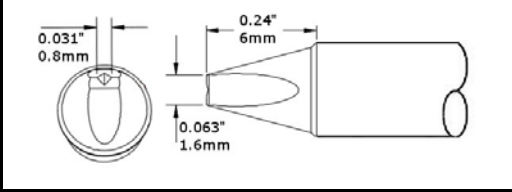
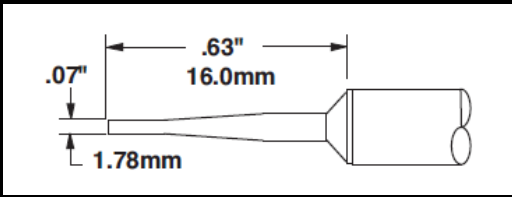
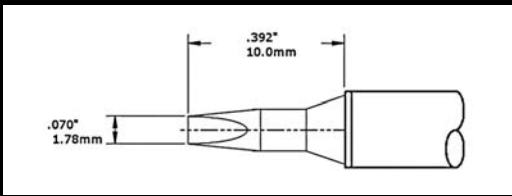
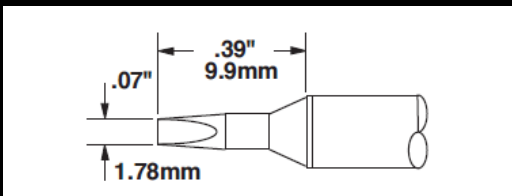
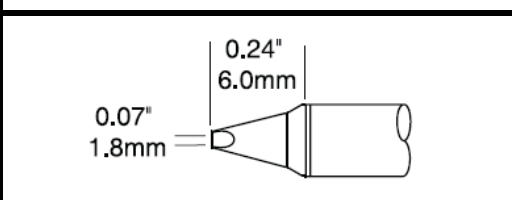
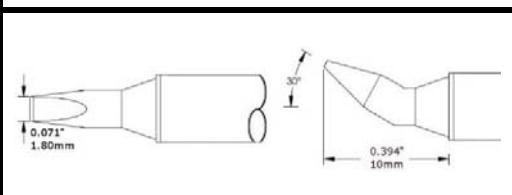
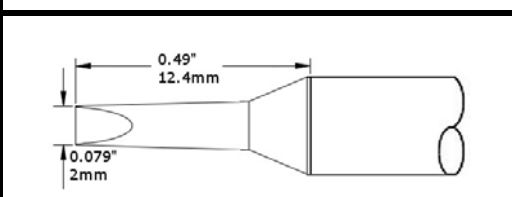
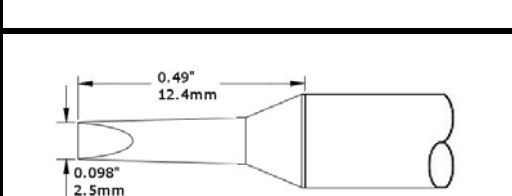
Chisel			
	CVC-5VG0016P CVC-6VG0016P CVC-7VG0016P CVC-8VG0016P CVC-9VG0016P	N/A	V-Groove Chisel P = Optimised geometry for best thermal performance 1.6mm x 6mm (.06" x .24") for THT pin soldering
	CVC-5CH0018A CVC-6CH0018A CVC-7CH0018A CVC-8CH0018A CVC-9CH0018A	STTC-542 STTC-042 STTC-142 STTC-842V1 STTC-842	Long Reach Chisel 60° 1.78mm x 16mm (.07" x .63")
	CVC-5CH0018L CVC-6CH0018L CVC-7CH0018L CVC-8CH0018L CVC-9CH0018L	STTC-537LL STTC-037LL STTC-137LL STTC-837LLV1 STTC-837LL	Chisel 30° Long Life 1.78mm x 1.0mm (.07" x .24")
	CVC-5CH0018S CVC-6CH0018S CVC-7CH0018S CVC-8CH0018S CVC-9CH0018S	STTC-537 STTC-037 STTC-137 STTC-837V1 STTC-837	Chisel Solder 30° 1.78mm x 9.9mm (.07" x .39")
	CVC-5CH0018P CVC-6CH0018P CVC-7CH0018P CVC-8CH0018P CVC-9CH0018P	STTC-537P STTC-037P STTC-137P STTC-837PV1 STTC-837P	Chisel 30° P = Optimised geometry for best thermal performance 1.8mm x 6.0mm (.07" x .24")
	CVC-5CH0018R CVC-6CH0018R CVC-7CH0018R CVC-8CH0018R CVC-9CH0018R	STTC-598 STTC-098 STTC-198 STTC-898V1 STTC-898	Long Reach Chisel 30° 1.8mm x 10.0mm (.07" x 0.4")
	CVC-5CH0020A CVC-6CH0020A CVC-7CH0020A CVC-8CH0020A CVC-9CH0020A	N/A	Long Reach Chisel 2.0mm x 12.4mm (.08" x 0.49")
	CVC-5CH0025A CVC-6CH0025A CVC-7CH0025A CVC-8CH0025A CVC-9CH0025A	N/A	Long Reach Chisel 2.5mm x 12.4mm (.10" x .49")

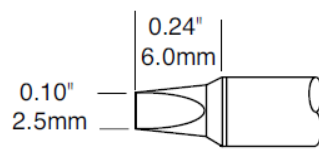
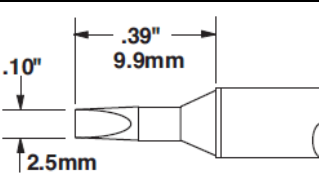
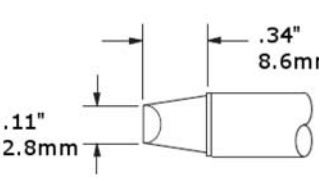
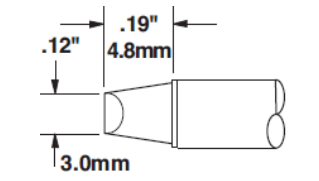
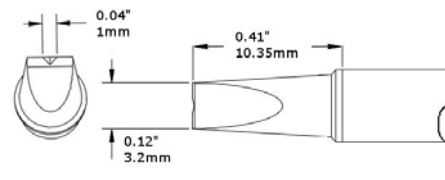
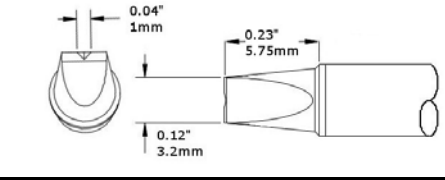
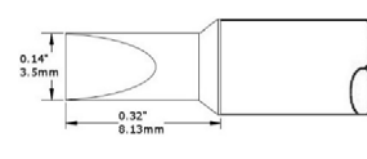
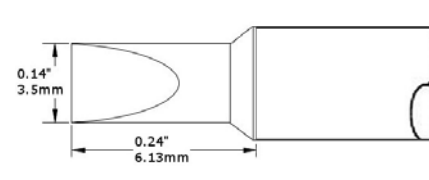
Chisel			
	CVC-5CH0025P CVC-6CH0025P CVC-7CH0025P CVC-8CH0025P CVC-9CH0025P	STTC-536P STTC-036P STTC-136P STTC-836PV1 STTC-836P	Chisel 30° P = Optimised geometry for best thermal performance 2.5mm x 6.0mm (.10" x .24")
	CVC-5CH0025S CVC-6CH0025S CVC-7CH0025S CVC-8CH0025S CVC-9CH0025S	STTC-536 STTC-036 STTC-136 STTC-836V1 STTC-836	Chisel 30° 2.5mm x 9.9mm (.10" x .39")
	CVC-5CH0034S CVC-6CH0034S CVC-7CH0034S CVC-8CH0034S CVC-9CH0034S	STTC-503 STTC-003 STTC-103 STTC-803V1 STTC-803	Chisel 90° 2.8mm x 8.6mm (.11" x .34")
	CVC-5CH0030S CVC-6CH0030S CVC-7CH0030S CVC-8CH0030S CVC-9CH0030S	STTC-513 STTC-013 STTC-113 STTC-813V1 STTC-813	Chisel 90° 3.0mm x 4.8mm (.12" x .19")
	CVC-5VG0032A CVC-6VG0032A CVC-7VG0032A CVC-8VG0032A CVC-9VG0032A	N/A	V-Groove Chisel 3.2mm x 10.35mm (.12" x .41") for THT pin soldering
	CVC-5VG0032P CVC-6VG0032P CVC-7VG0032P CVC-8VG0032P CVC-9VG0032P	N/A	V-Groove Chisel P = Optimised geometry for best thermal performance 3.2mm x 5.75mm (.12" x .23") for THT pin soldering
	CVC-5CH0035S CVC-6CH0035S CVC-7CH0035S CVC-8CH0035S CVC-9CH0035S	N/A	Chisel 3.5mm x 8.13mm (.14" x .32")
	CVC-5CH0035P CVC-6CH0035P CVC-7CH0035P CVC-8CH0035P CVC-9CH0035P	N/A	Chisel P = Optimised geometry for best thermal performance 3.5mm x 6.13mm (.14" x .24")

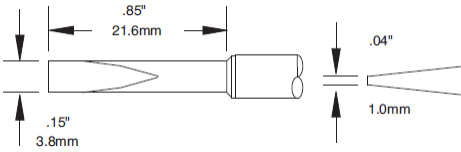
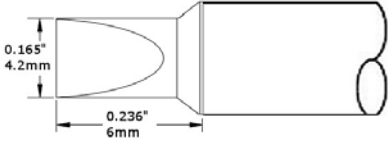
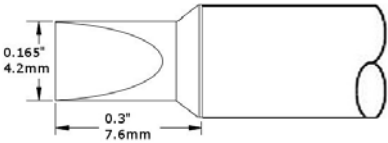
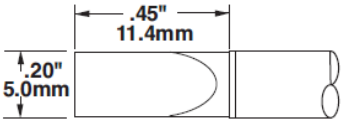
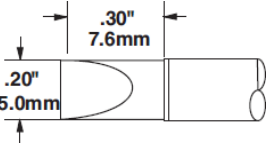
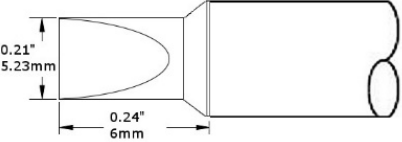
Chisel			
	CVC-5CH2238A CVC-6CH2238A CVC-7CH2238A CVC-8CH2238A CVC-9CH2238A	STTC-520 STTC-020 STTC-120 STTC-820V1 STTC-820	Long Reach Chisel 12° 3.8mm x 21.6mm (.15" x .85")
	CVC-5CH0040P CVC-6CH0040P CVC-7CH0040P CVC-8CH0040P CVC-9CH0040P	N/A	Chisel P = Optimised geometry for best thermal performance 4.2mm x 6mm (.165" x .24")
	CVC-5CH0040S CVC-6CH0040S CVC-7CH0040S CVC-8CH0040S CVC-9CH0040S	N/A	Chisel 4mm x 7.6mm (.17" x 0.3")
	CVC-5CH0050A CVC-6CH0050A CVC-7CH0050A CVC-8CH0050A CVC-9CH0050A	STTC-565 STTC-065 STTC-165 STTC-865V1 STTC-865	Large Chisel 5.0mm x 11.4mm (.20" x .45")
	CVC-5CH0050S CVC-6CH0050S CVC-7CH0050S CVC-8CH0050S CVC-9CH0050S	STTC-517 STTC-017 STTC-117 STTC-817V1 STTC-817	Large Chisel 5.0mm x 7.6mm (.20" x .30")
	CVC-5CH0050P CVC-6CH0050P CVC-7CH0050P CVC-8CH0050P CVC-9CH0050P	N/A	Chisel P = Optimised geometry for best thermal performance 5.2mm x 6mm (.21" x .24")

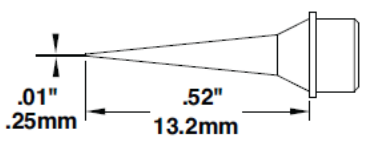
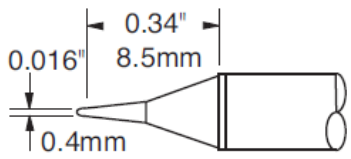
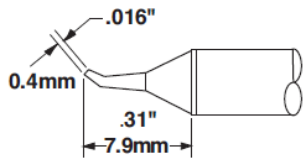
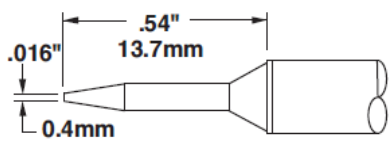
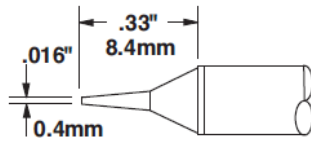
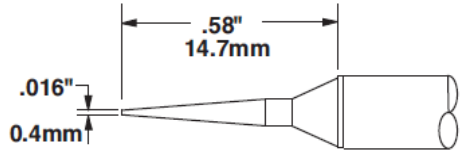
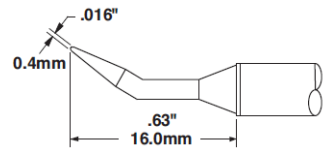
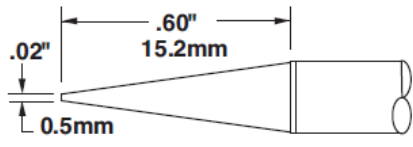
Conical			
	CVC-5CN0003A CVC-6CN0003A CVC-7CN0003A CVC-8CN0003A CVC-9CN0003A	STTC-590 STTC-090 STTC-190 STTC-890V1 STTC-890	Fine and Long Reach Conical 0.25mm x 13.2mm (.01" x .52")
	CVC-5CN0004P CVC-6CN0004P CVC-7CN0004P CVC-8CN0004P CVC-9CN0004P	STTC-545P STTC-045P STTC-145P STTC-845PV1 STTC-845P	Conical Sharp P = Optimised geometry for best thermal performance 0.4mm x 8.5mm (.016" x .34")
	CVC-5CN0004R CVC-6CN0004R CVC-7CN0004R CVC-8CN0004R CVC-9CN0004R	STTC-526 STTC-026 STTC-126 STTC-826V1 STTC-826	Conical Sharp Bent 30° 0.4mm x 7.9mm (.016" x .31")
	CVC-5CN1304A CVC-6CN1304A CVC-7CN1304A CVC-8CN1304A CVC-9CN1304A	STTC-506 STTC-006 STTC-106 STTC-806V1 STTC-806	Conical Sharp 0.4mm x 13.7mm (.016" x .54")
	CVC-5CN1404S CVC-6CN1404S CVC-7CN1404S CVC-8CN1404S CVC-9CN1404S	STTC-522 STTC-022 STTC-122 STTC-822V1 STTC-822	Conical Sharp 0.4mm x 8.4mm (.016" x .33")
	CVC-5CN1504A CVC-6CN1504A CVC-7CN1504A CVC-8CN1504A CVC-9CN1504A	STTC-545 STTC-045 STTC-145 STTC-845V1 STTC-845	Conical Sharp 0.4mm x 14.7mm (.016" x .58")
	CVC-5CN1604R CVC-6CN1604R CVC-7CN1604R CVC-8CN1604R CVC-9CN1604R	STTC-540 STTC-040 STTC-140 STTC-840V1 STTC-840	Conical Sharp Bent 30° Long Reach 0.4mm x 16mm (.016" x .63")
	CVC-5CN0005A CVC-6CN0005A CVC-7CN0005A CVC-8CN0005A CVC-9CN0005A	STTC-543 STTC-043 STTC-143 STTC-843V1 STTC-843	Conical Sharp 0.5mm x 15.2mm (.02" x .6")

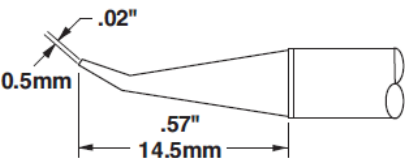
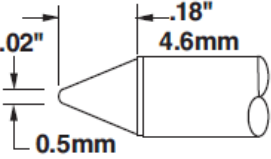
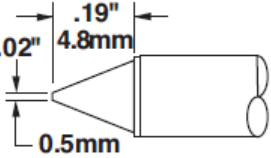
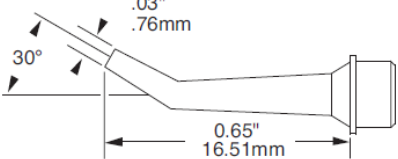
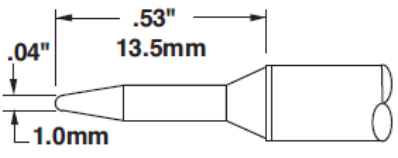
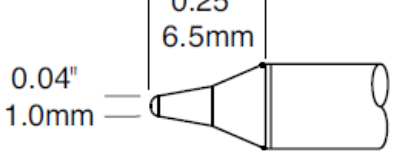
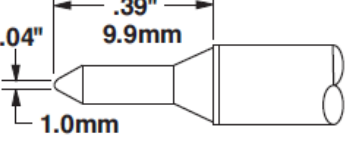
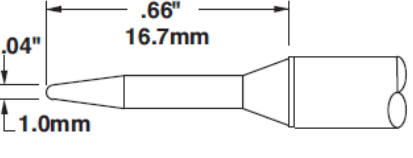
Conical			
	CVC-5CN0005R CVC-6CN0005R CVC-7CN0005R CVC-8CN0005R CVC-9CN0005R	STTC-544 STTC-044 STTC-144 STTC-844V1 STTC-844	Conical Sharp Bent 30° Long Reach 0.5mm x 14.5mm (.02" x .57")
	CVC-5CN0005S CVC-6CN0005S CVC-7CN0005S CVC-8CN0005S CVC-9CN0005S	STTC-511 STTC-011 STTC-111 STTC-811V1 STTC-811	Conical Sharp 0.5mm x 4.6mm (.02" x .18")
	CVC-5CN4805S CVC-6CN4805S CVC-7CN4805S CVC-8CN4805S CVC-9CN4805S	STTC-516 STTC-016 STTC-116 STTC-816V1 STTC-816	Conical Sharp 0.5mm x 4.8mm (.02" x .19")
	SMC-5HK0008S SMC-6HK0008S SMC-7HK0008S SMC-8HK0008S SMC-9HK0008S	SMTC-5171 SMTC-0171 SMTC-1171 SMTC-8171V1 SMTC-8171	Conical Bent 30° 0.76mm x 16.51mm (.03" x .65")
	CVC-5CN0010A CVC-6CN0010A CVC-7CN0010A CVC-8CN0010A CVC-9CN0010A	STTC-501 STTC-001 STTC-101 STTC-801V1 STTC-801	Conical 1.0mm x 13.5mm (.04" x .53")
	CVC-5CN0010P CVC-6CN0010P CVC-7CN0010P CVC-8CN0010P CVC-9CN0010P	STTC-501P STTC-001P STTC-101P STTC-801PV1 STTC-801P	Conical P = Optimised geometry for best thermal performance 1.0mm x 6.5mm (.04" x .25")
	CVC-5CN0010S CVC-6CN0010S CVC-7CN0010S CVC-8CN0010S CVC-9CN0010S	STTC-531 STTC-031 STTC-131 STTC-831V1 STTC-831	Conical 1.0mm x 9.9mm (.04" x .39")
	CVC-5CN1710A CVC-6CN1710A CVC-7CN1710A CVC-8CN1710A CVC-9CN1710A	STTC-507 STTC-007 STTC-107 STTC-807V1 STTC-807	Conical 1.0mm x 16.7mm (.04" x .66")

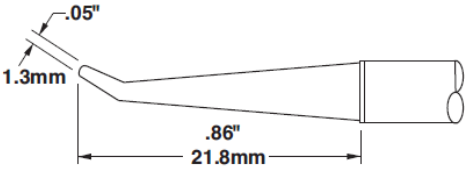
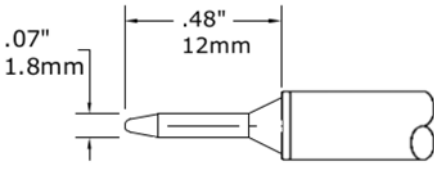
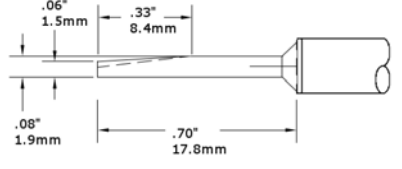
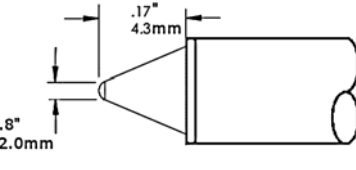
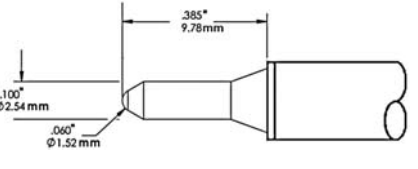
Conical			
	CVC-5CN0013R CVC-6CN0013R CVC-7CN0013R CVC-8CN0013R CVC-9CN0013R	STTC-541 STTC-041 STTC-141 STTC-841V1 STTC-841	Conical Bent 30° Long Reach 1.3 mm x 21.8mm (.05" x .86")
	CVC-5CN1208S CVC-6CN1208S CVC-7CN1208S CVC-8CN1208S CVC-9CN1208S	STTC-502 STTC-002 STTC-102 STTC-802V1 STTC-802	Conical 1.8mm x 12.0mm (.07"x .48")
	CVC-5LG1802A CVC-6LG1802A CVC-7LG1802A CVC-8LG1802A CVC-9LG1802A	STTC-583 STTC-083 STTC-183 STTC-883V1 STTC-883	V-Groove 0,9mm, length 8.4mm Dia. 1.9mm x 17.8mm (.08" x .70") for THT pin soldering
	CVC-5CN4302S CVC-6CN4302S CVC-7CN4302S CVC-8CN4302S CVC-9CN4302S	STTC-512 STTC-012 STTC-112 STTC-812V1 STTC-812	Conical 2.0mm x 4.3mm (.8" x .17")
	CVC-5CN1002S CVC-6CN1002S CVC-7CN1002S CVC-8CN1002S CVC-9CN1002S	STTC-532 STTC-032 STTC-132 STTC-832V1 STTC-832	Conical 2.5mm x 9.78mm (.10"x .385")

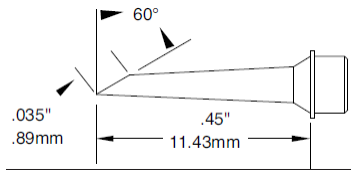
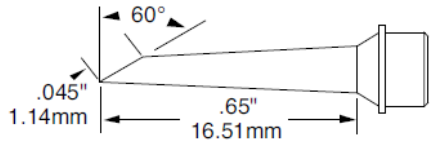
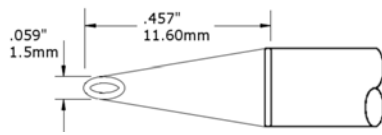
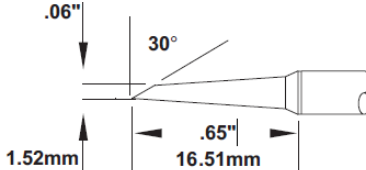
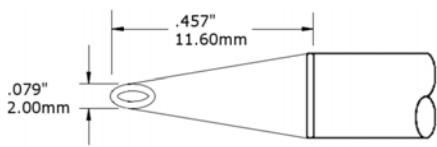
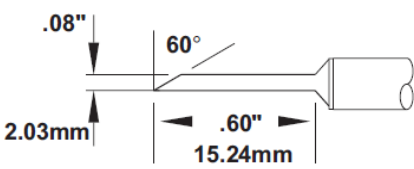
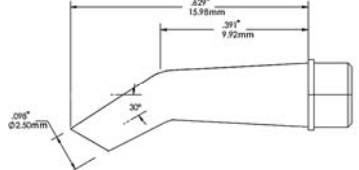
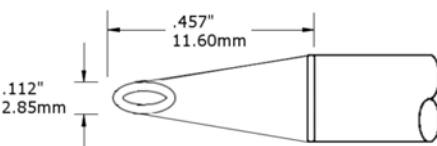
Hoof			
	SMC-5HF6009S SMC-6HF6009S SMC-7HF6009S SMC-8HF6009S SMC-9HF6009S	SMTC-5175 SMTC-0175 SMTC-1175 SMTC-8175V1 SMTC-8175	Micro Hoof 60° 0.89mm x 11.43mm (.035"x.45")
	SMC-5HF6011S SMC-6HF6011S SMC-7HF6011S SMC-8HF6011S SMC-9HF6011S	SMTC-5174 SMTC-0174 SMTC-1174 SMTC-8174V1 SMTC-8174	Micro Hoof 60° Long Reach 1.14mm x 16.51mm (.045"x.65")
	SMC-5HF0015V SMC-6HF0015V SMC-7HF0015V SMC-8HF0015V SMC-9HF0015V	SMTC-5184 SMTC-0184 SMTC-1184 SMTC-8184V1 SMTC-8184	Concave Hoof 1.5mm x 11.6mm
	SMC-5HF6015S SMC-6HF6015S SMC-7HF6015S SMC-8HF6015S SMC-9HF6015S	SMTC-5167 SMTC-0167 SMTC-1167 SMTC-8167V1 SMTC-8167	Hoof 30° Long Reach 1.5mm x 16.51mm (.06"x.65")
	SMC-5HF0020V SMC-6HF0020V SMC-7HF0020V SMC-8HF0020V SMC-9HF0020V	SMTC-5185 SMTC-0185 SMTC-1185 SMTC-8185V1 SMTC-8185	Concave Hoof 2mm x 11.6mm
	SMC-5HF6020S SMC-6HF6020S SMC-7HF6020S SMC-8HF6020S SMC-9HF6020S	SMTC-5169 SMTC-0169 SMTC-1169 SMTC-8169V1 SMTC-8169	Hoof 60° Long Reach 2mm x 15.24mm (.08" x .60")
	SMC-5HF3025S SMC-6HF3025S SMC-7HF3025S SMC-8HF3025S SMC-9HF3025S	SMTC-5183 SMTC-0183 SMTC-1183 SMTC-8183V1 SMTC-8183	Concave Hoof 30° Bent 2.5mm x 16.0mm
	SMC-5HF0030V SMC-6HF0030V SMC-7HF0030V SMC-8HF0030V SMC-9HF0030V	SMTC-5186 SMTC-0186 SMTC-1186 SMTC-8186V1 SMTC-8186	Concave Hoof 2.85mm x 11.6mm

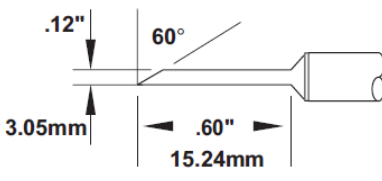
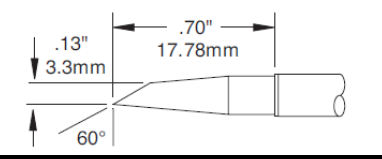
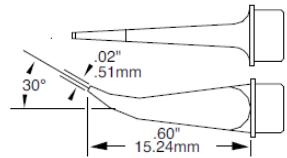
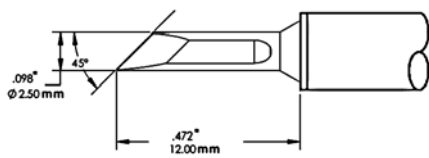
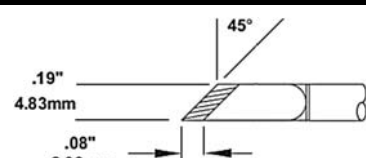
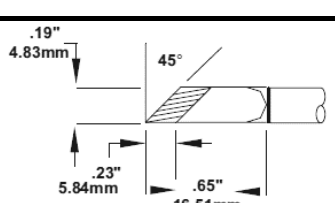
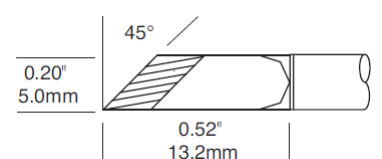
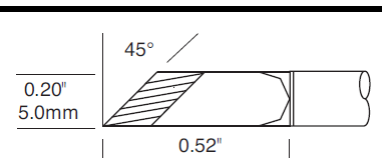
Hoof			
	SMC-5HF6030S SMC-6HF6030S SMC-7HF6030S SMC-8HF6030S SMC-9HF6030S	SMTC-5170 SMTC-0170 SMTC-1170 SMTC-8170V1 SMTC-8170	Hoof 60° Long Reach 3mm x 15.24mm (.12" x .60")
	SMC-5HF6033S SMC-6HF6033S SMC-7HF6033S SMC-8HF6033S SMC-9HF6033S	SMTC-5147 SMTC-0147 SMTC-1147 SMTC-8147V1 SMTC-8147	Hoof 60° Long Reach 3.3mm x 17.78mm (.13" x .70")
Hook			
	SMC-5HK005S SMC-6HK005S SMC-7HK005S SMC-8HK005S SMC-9HK005S	SMTC-5172 SMTC-0172 SMTC-1172 SMTC-8172V1 SMTC-8172	Hook Long 30° 0.5mm x 15.24mm (.02"x.06")
Knife			
	SMC-5KN0025S SMC-6KN0025S SMC-7KN0025S SMC-8KN0025S SMC-9KN0025S	SMTC-5165 SMTC-0165 SMTC-1165 SMTC-8165V1 SMTC-8165	Knife 45°, 2.5mm x 12.0mm (.098" x .472")
	SMC-5KN0048S SMC-6KN0048S SMC-7KN0048S SMC-8KN0048S SMC-9KN0048S	SMTC-5161 SMTC-0161 SMTC-1161 SMTC-8161V1 SMTC-8161	Knife 45° - Increased tinned Area Length 2.03mm (.08") 4.8mm x 16.51mm (.18" x .65")
	SMC-5KN0048W SMC-6KN0048W SMC-7KN0048W SMC-8KN0048W SMC-9KN0048W	SMTC-5173 SMTC-0173 SMTC-1173 SMTC-8173V1 SMTC-8173	Knife 45° - Increased tinned Area Length 5.84mm (.23") 4.8mm x 16.51mm (.18" x .65")
	SMC-5KN0050P SMC-6KN0050P SMC-7KN0050P SMC-8KN0050P SMC-9KN0050P	STTC-5173P STTC-0173P STTC-1173P STTC-8173PV1 STTC-8173P	Knife 45°, P = Optimised geometry for best thermal performance 5.0mm x 13.2mm (.20" x .52")
	SMC-5KN0050X SMC-6KN0050X SMC-7KN0050X SMC-8KN0050X SMC-9KN0050X	STTC-5173PLL STTC-0173PLL STTC-1173PLL STTC-8173PLLV1 STTC-8173PLL	Knife 45°, Long Life, P = Optimised geometry for best thermal performance 5.0mm x 13.2mm (.20" x .52")

