

COM.LoRaWAN868 v2.0

SKU:M031-C4

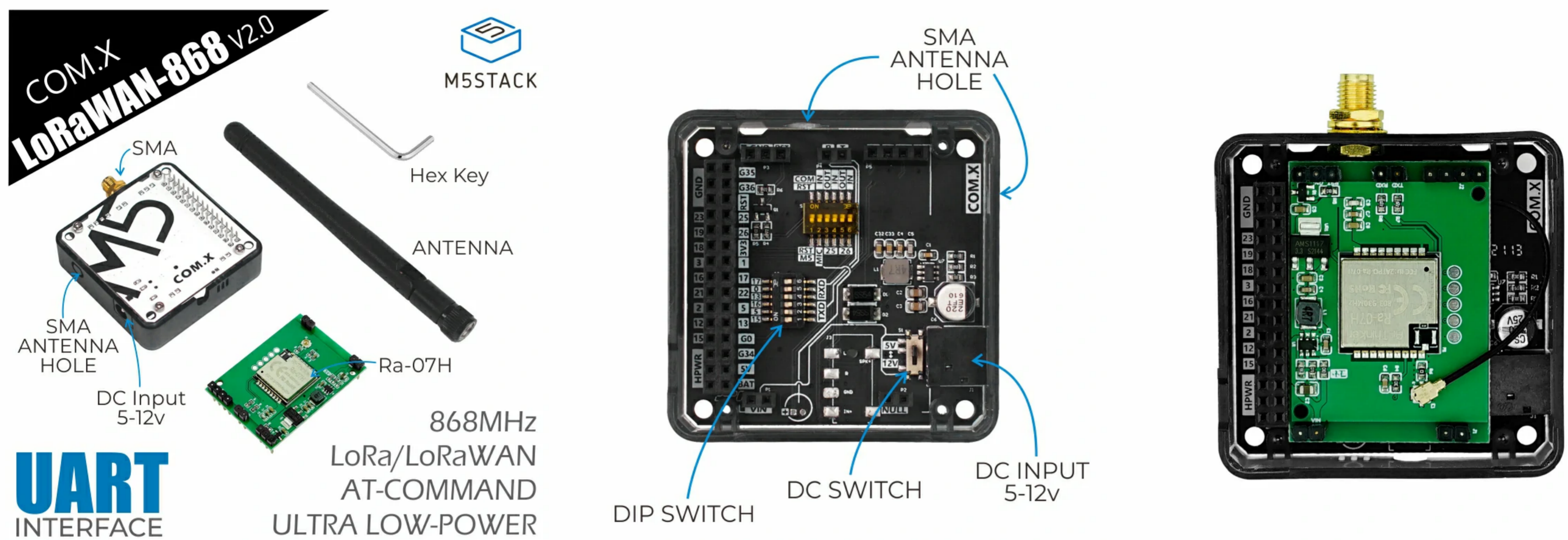

Description

COM.LoRaWAN868 v2.0 is a LoRaWAN communication module suitable for 868MHz frequency launched by M5Stack. The module adopts the ASR6501 scheme, which supports long-distance communication and has high sensitivity characteristics. The module integrates the LoRaWAN protocol stack, adopts the serial communication interface (using AT command set for control), and can be used as a collection node for a large number of access gateways for data collection management. This module is suitable for long-distance low-power IoT communication applications, such as the deployment of environmental monitoring nodes.

Notice

When used with the **FIRE** main control, due to the PSRAM pin conflict, please switch the DIP switch pins of the module base to TX(0/13), RX(5/15), and the device can use USB/ External DC is used for power supply.

When used with **Core2** series main control, due to the different order of the base pin array, COM.X base pins TX(16), RX(17) correspond to the actual pins TX(14), RX of the Core2 main control (13) The equipment needs to use external DC for power supply.

The module base has a DC power input interface. Please strictly follow the input range (5-12V) to prevent damage to the module when using this interface to connect to the power supply. The internal power DIP switch can adjust the voltage level of the internal terminal VIN to adapt to different modules.

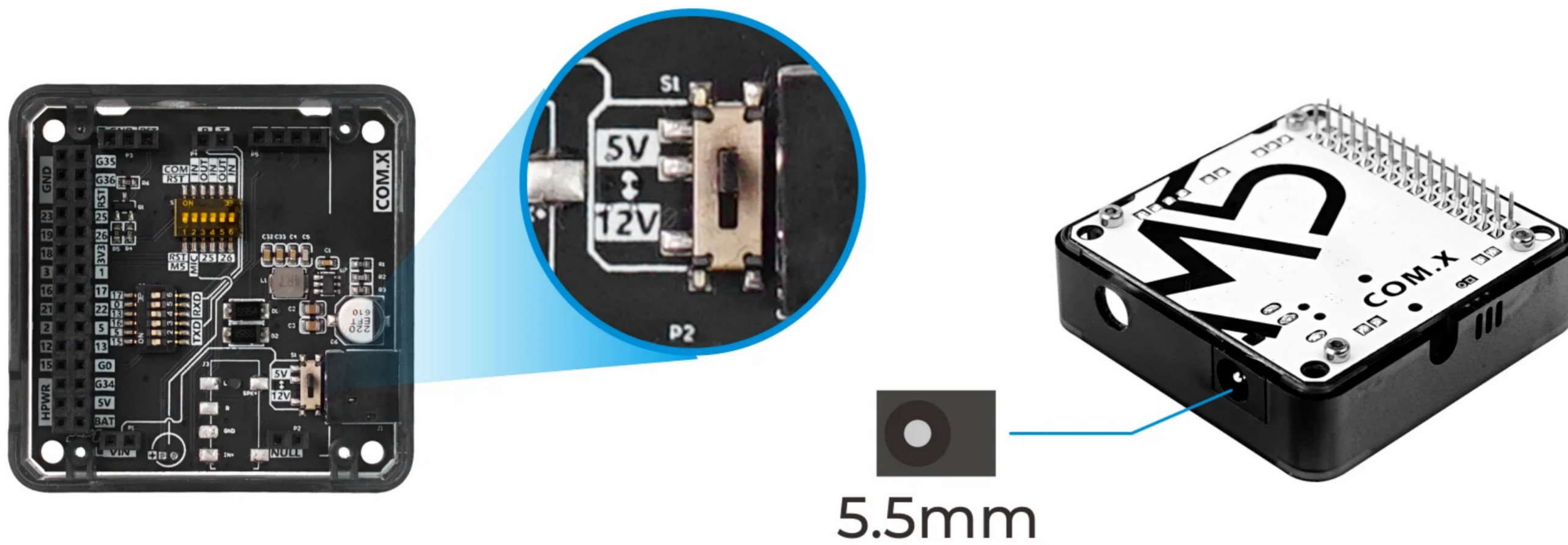

Product Features

- ASR6501
- Operating frequency: 868MHz
- SMA antenna
- Communication interface: UART
- Command protocol: AT command

包含

- 1x COM.LoRaWAN868 v2.0
- 1x SMA Antenna

Application

- Automatic remote meter reading
- Intelligent traffic intelligent parking lot
- Remote irrigation and environmental monitoring

868MHz supported countries

Albania/Andorra/Armenia/Austria/Bahrain/Bangladesh/Belarus/Belgium/Myanmar/Bosnia and Herzegovina/Brunei

Darussalam/Bulgaria/Cambodia/Cambodia/Croatia/Cyprus/Denmark/Egypt/Estonia/

Finland/France/Germany/Germany

Guatemala/Hungary/Iceland/Iran/Ireland/Italy/Laos/Latvia/Lebanon/Liechtenstein/Lithuania

/Luxembourg/Macedonia, the former Federal Republic of

Yugoslavia/Malta/Moldova/Montenegro/Morocco/Netherlands/Netherlands/New

Zealand/Nigeria/Norway/Oman/Pakistan/Poland/Portugal/Qatar/Romania/Saudi

Arabia/Serbia/Singapore/Slovenia/South

Africa/Spain/Sweden/Switzerland/Tunisia/Turkey/Ukraine/UAE/UK/Vietnam



Specifications

Resources	Parameter
Communication chip	ASR6501
Operating frequency	868MHz
LoRaWAN Version	v1.0.1
Minimum receiving sensitivity	-137dBm (SF=12/BW=125KHz)
Maximum transmit power	+21dBm
communication	UART 115200bps
Net weight	27.4g
Gross weight	70.4g
Product Size	54.2*54.2*13.2mm
Package Size	165*60*36mm





Related Link

- [LoRaWAN868 AT command set](#)
- [LoRaWAN Regional parameters](#)

Example

Arduino

- [COM.LoRaWAN868 v2.0 OTAA with M5Core](#)

Pin mapping

M5CORE	RX	TX
COM.LoRaWAN868 v2.0	G17	G16

Schematic

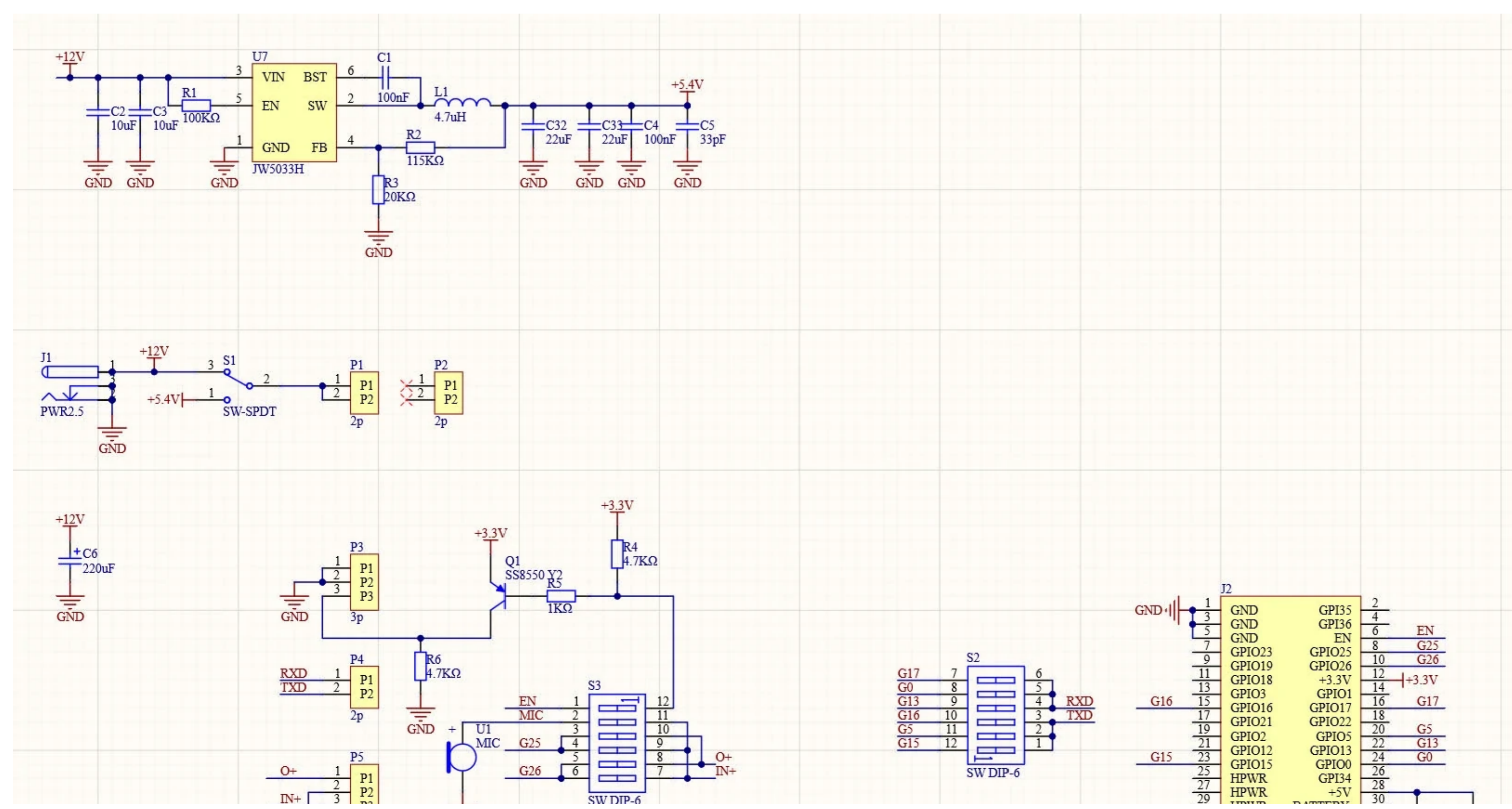



FAQ

COMMON

Q1: Consultation for after-sales problems of products +

Describe the problems encountered in detail. Screenshots of the programs involved or files can be added as attachments and sent to M5Stack's official after-sales email

support@m5stack.com

Q2: Code Resources, Cases, User Communication +

M5Stack related resource links: Official Github

<https://github.com/m5stack>

<https://m5stack.hackster.io/>

<https://community.m5stack.com/>