



### Main

Range of product	Modicon LMC078
Product or component type	Motion controller
Product specific application	Material handling Packaging Material working
Discrete I/O number	20
Battery type	3 V lithium battery

### Complementary

Discrete input number	12 for total input 8 for regular input 4 for capture input
Discrete input logic	Sink
Discrete input voltage	24 V
Discrete input voltage type	DC
Voltage state 1 guaranteed	15...30 V for input
Voltage state 0 guaranteed	-3...5 V for input
Discrete input current	4 mA
Input impedance	6 kOhm
Configurable filtering time	0.1...4290 ms for regular input 0.1...4290 ms for capture input
Discrete output number	8 output
Discrete output logic	Source
Discrete output voltage	24 V DC
Output voltage limits	19.2...28.8 V
Protection type	Short-circuit protection
Maximum input/output number	768 distributed for discrete inputs and outputs 364 distributed for analog inputs and outputs
[Us] rated supply voltage	24 V DC
Supply voltage limits	20.4...30 V
[In] rated current	500 MA for per output 2 A for for all outputs
Peak current	2 A (duration = 1 s)
Execution time per instruction	2 ns
Memory type	128 MB NVRAM 512 MB RAM
Data storage equipment	512 MB SD card
Programming language	SFC (sequential function chart) CFC (continuous function chart) ST (structured text) IL (instruction list) LD (ladder) FBD (function block diagram)
Realtime clock	With clock, clock drift +/- 1 s/day
Data backed up	Battery variables of type retain and retain persistent Battery date and hour

The information provided in this documentation contains general descriptions and/or technical characteristics of the performance of the products contained herein. This documentation is not intended as a substitute for and is not to be used for determining suitability or reliability of these products for specific user applications. It is the duty of any such user or integrator to perform the appropriate and complete risk analysis, evaluation and testing of the products with respect to the relevant specific application or use thereof. Neither Schneider Electric Industries SAS nor any of its affiliates or subsidiaries shall be responsible or liable for misuse of the information contained herein.

Battery life	10 year(s)
Integrated connection type	1 isolated serial link with female RJ45 connectorModbus with master/slave RTU/ASCII or character mode ASCII, physical interface: RS232/RS485, transmission rate: 480 Mbit/s 1 CAN port with male SUB-D 9 connectorCANopen with master 1 isolated serial link with mini B USB connector, transmission rate: 480 Mbit/s 1 encoder with screw terminal block connector 1 isolated serial link with female RJ45 connector, physical interface: SERCOS III 1 isolated serial link with female RJ45 connectorEthernet Modbus TCP/IP with slave, physical interface: 10BASE-T/100BASE-TX, transmission rate: 300...115200 bps 1 isolated serial link with USB type A connector
Local signalling	1 LED green with PRG marking for programming indication 1 LED green, orange and red with SIII marking for SERCOS III bus status 1 LED green/red with STS marking for status of the module (Mod Status) 1 LED green/red with CAN marking for CANopen bus status
Marking	CE
Mounting support	Screw clamp
Width	45 mm
Height	230 mm
Depth	220 mm
Net weight	2.2 kg



## Environment

Standards	CSA C22.2 No 142 UL 508
Product certifications	CSA UL
Ambient air temperature for operation	5...55 °C (vertical installation)
Ambient air temperature for storage	-25...70 °C
Relative humidity	5...95 % without condensation
IP degree of protection	IP20 conforming to IEC 61131-2
Pollution degree	2
Operating altitude	0...2000 m without derating
Storage altitude	0...3000 m
Vibration resistance	10 m/s <sup>2</sup>
Shock resistance	100 m/s <sup>2</sup>

## Packing Units

Unit Type of Package 1	PCE
Number of Units in Package 1	1
Package 1 Weight	2.188 kg
Package 1 Height	10.6 cm
Package 1 width	33.2 cm
Package 1 Length	44.6 cm
Unit Type of Package 2	P06
Number of Units in Package 2	12
Package 2 Weight	36.52 kg
Package 2 Height	80.0 cm
Package 2 width	80.0 cm
Package 2 Length	60.0 cm

## Offer Sustainability

Sustainable offer status	Green Premium product
REACH Regulation	 <a href="#">REACH Declaration</a>
EU RoHS Directive	Pro-active compliance (Product out of EU RoHS legal scope)  <a href="#">EU RoHS Declaration</a>
Mercury free	Yes
RoHS exemption information	 Yes

China RoHS Regulation	<a href="#">China RoHS Declaration</a>
Environmental Disclosure	<a href="#">Product Environmental Profile</a>
Circularity Profile	<a href="#">End Of Life Information</a>
WEEE	The product must be disposed on European Union markets following specific waste collection and never end up in rubbish bins
PVC free	Yes

### Contractual warranty

Warranty	18 months
----------	-----------

Presentation

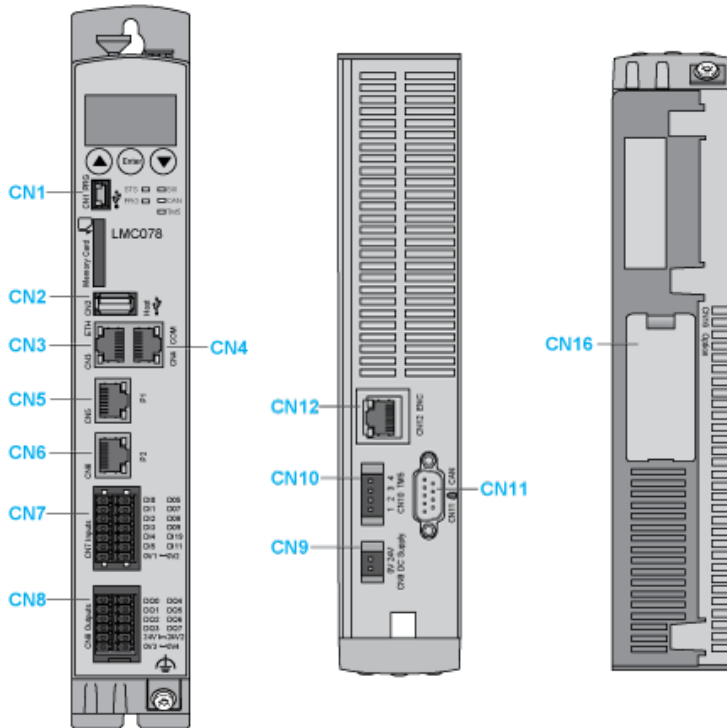

- CN1 : USB mini-B (PRG)
- CN2 : USB A port (Host)
- CN3 : Ethernet port (ETH)
- CN4 : Serial line port (COM)
- CN5 : Sercos, port 1 (P1)
- CN6 : Sercos, port 2 (P2)
- CN7 : Digital inputs
- CN8 : Digital outputs
- CN9 : 24 Vdc
- CN10 : Not used
- CN11 : CANopen port (CAN)
- CN12 : Master encoder input (ENC)
- CN16 : Slot for optional communication module

## Modicon LMC078

### Dimensions

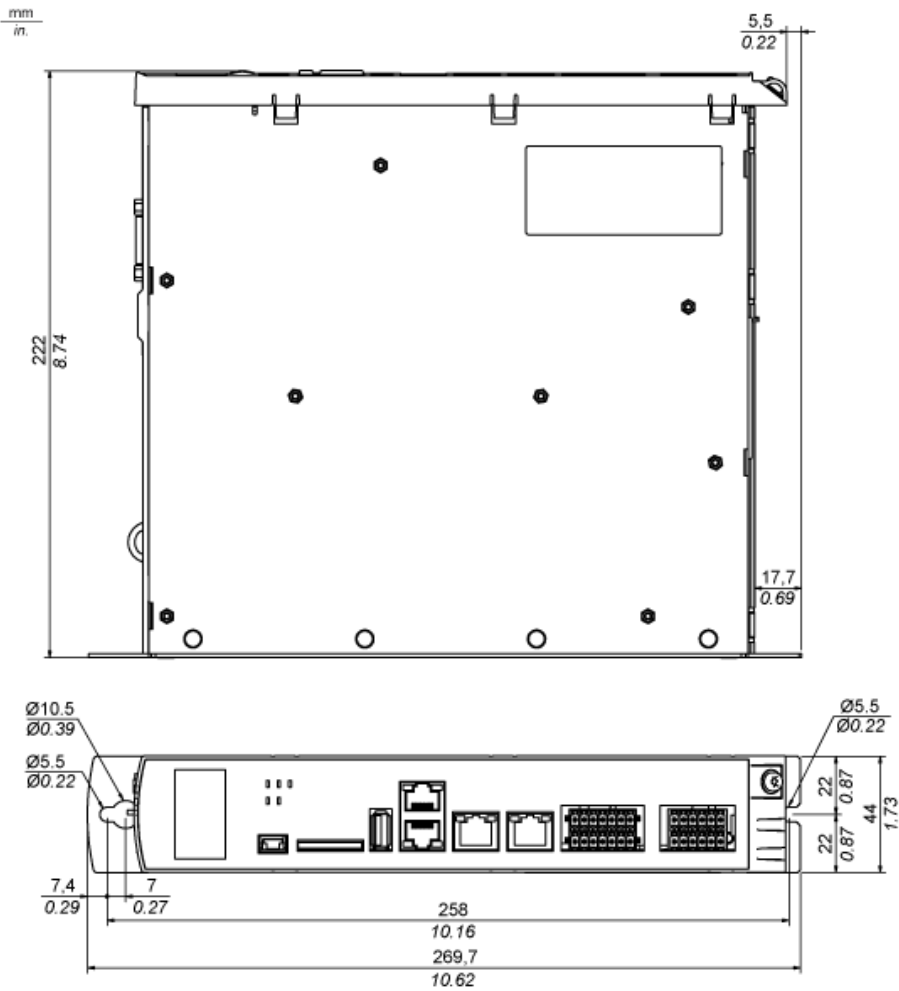

Mounting Clearance

Mounting

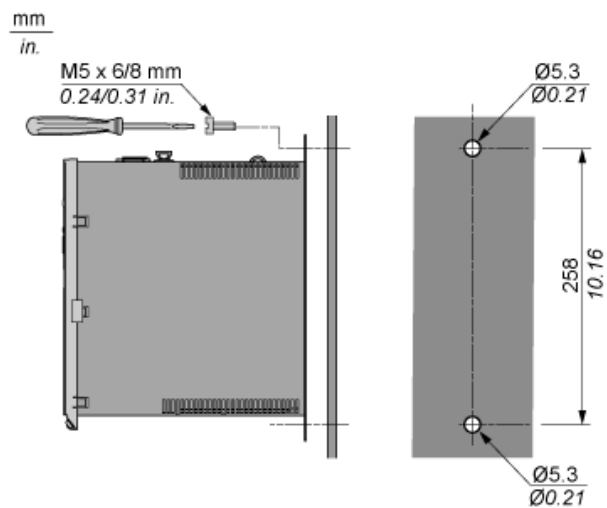

Mounting Position

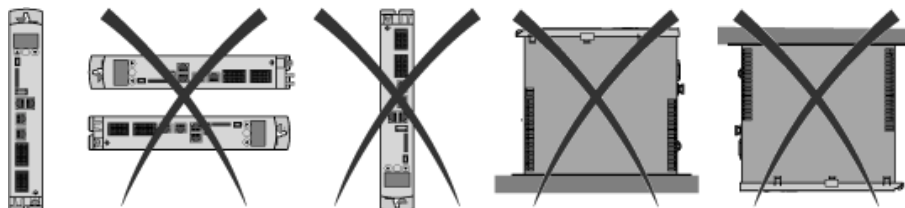

Clearance

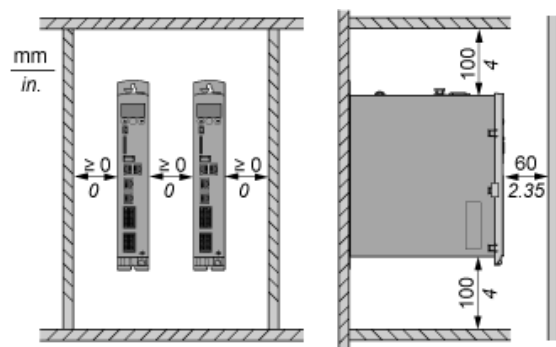

Connections and Schema

DC Power Supply

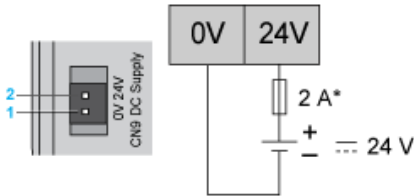

\* : Type T fuse

Pin	Description
1	0 Vdc
2	24 Vdc

Grounding

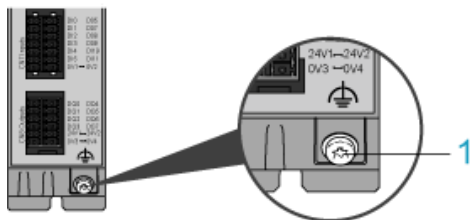

1 : Grounding terminal

mm	4.3	4.3
in.	0.17	0.17

USB Mini-B Port Connection

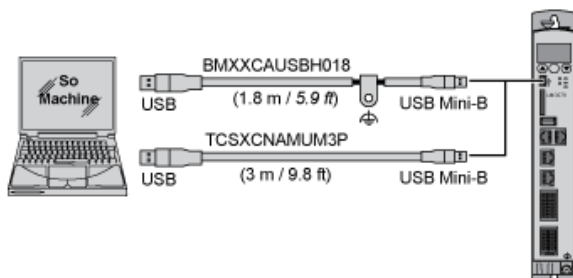

SD Card Slot

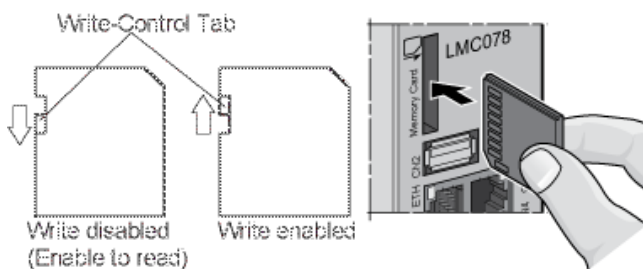

## Ethernet Port

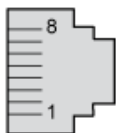

Pin	Signal	Description
1	TD+	Transmit data+
2	TD-	Transmit data-
3	RD+	Receive data+
4	-	-
5	-	-
6	RD-	Receive data-
7	-	-
8	-	-

## CAN Port

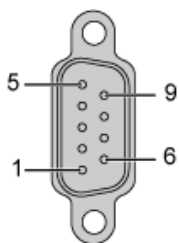

This table describes the pins of the CAN port:

Pin N°	Signal	Description
1	-	Reserved
2	CAN_L	CAN_L bus line (Low)
3	CAN_GND	CAN 0 Vdc
4	-	Reserved
5	-	Reserved
6	GND	0 Vdc
7	CAN_H	CAN_H bus line (High)
8	-	Reserved
9	-	Reserved

## Sercos Port

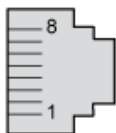

Pin	Signal	Description
1	TD+	Transmit data +
2	TD-	Transmit data -
3	RD+	Receive data +
4	-	Reserved
5	-	Reserved
6	RD-	Receive data -
7	-	Reserved



Pin	Signal	Description
8	-	Reserved

## Serial Line Port

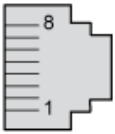

Pin	RS-485 signal	RS-232 signal
1	-	TxD
2	-	RxD
3	-	CTS
4	D1 (A+)	-
5	D0 (B-)	-
6	-	RTS
7	-	-
8	0 Vdc	0 Vdc

TXD : Transmitted data

RXD : Received data

CTS : Clear to send

RTS : Request to send

0 Vdc : Common

D1 (A+) : Modbus D1

D0 (B-) : Modbus D0

- : Reserved

## Encoder Interface

RJ45 with 2 additional power supply contacts (A, B)

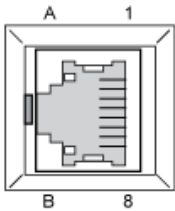

Type	Pin	Designation	Description
Hiperface encoder	1	COS	Cosine track
	2	REFCOS	Reference signal cosinus
	3	SIN	Sinusoidal trace
	4	RS485+	Parameter channel +
	5	RS485-	Parameter channel -
	6	REFSIN	Reference signal sine
	7	-	Reserved
	8	-	Reserved
	A	10 Vdc	Encoder supply
	B	GND	Ground
Incremental encoder	1	B+	Track signal B+
	2	B-	Track signal B-
	3	A+	Track signal A+
	4	Z+	Track signal Z+

Type	Pin	Designation	Description
5	Z-	Track signal Z-	
6	A-	Track signal A-	
7	-	Reserved	
8	-	Reserved	
A	5 Vdc	Encoder supply	
B	GND	Ground	

### Digital Inputs

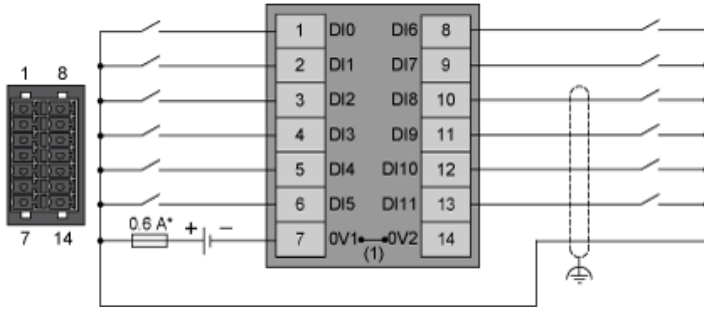

\* : Type T fuse

(1) The 0V1 and 0V2 terminals (7 and 14) are connected internally

This table describes the pin assignment of the CN7 connector:

Pin	Label	Description
1	DI0	Digital input 0
2	DI1	Digital input 1
3	DI2	Digital input 2
4	DI3	Digital input 3
5	DI4	Digital input 4
6	DI5	Digital input 5
7	0V1	0V1 Reference potential DI0...DI11
8	DI6	Digital input 6
9	DI7	Digital input 7
10	DI8	Advanced digital input 8 (touchprobe/interrupt)
11	DI9	Advanced digital input 9 (touchprobe/interrupt)
12	DI10	Advanced digital input 10 (touchprobe/interrupt)
13	DI11	Advanced digital input 11 (touchprobe/interrupt)
14	0V2	Reference potential DI0...DI11

### Digital Outputs

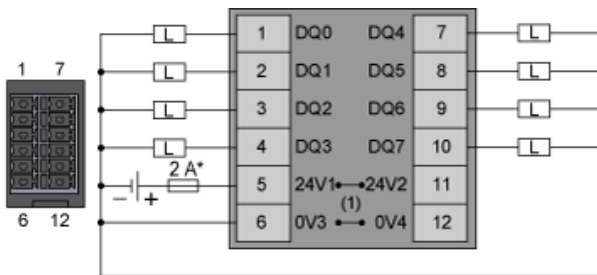

\* : Type T fuse

(1) The 24V1 and 24V2 terminals (5 and 11) are connected internally. The 0V3 and 0V4 terminals (6 and 12) are connected internally.

Pin	Label	Description
1	DQ0	Digital output 0
2	DQ1	Digital output 1
3	DQ2	Digital output 2

Pin	Label	Description
4	DQ3	Digital output 3
5	24V1	Supply voltage DQ0...DQ7 (24 Vdc)
6	0V3	Supply voltage DQ0...DQ7 (0 Vdc)
7	DQ4	Digital output 4
8	DQ5	Digital output 5
9	DQ6	Digital output 6
10	DQ7	Digital output 7
11	24V2	24V2 Supply voltage DQ0...DQ7 (24 Vdc)
12	0V4	Supply voltage DQ0...DQ7 (0 Vdc)