

# OSCONIQ® P2226 Eco1 Colours

IHE-P201-xxxx-SC221.

## Product Overview

At the heart of each OSCONIQ® P2226 Eco1 is one OSRAM Opto Semiconductor OSCONIQ® P2226. These are mid-power LEDs, which are ideal for efficient and homogeneous lighting applications. The combination of a small/medium lumen package, a wide beam angle and a compact footprint is perfect for uniform light distribution. Eco1's are compact, powerful LED light sources built on FR4 with thermal vias for optimal thermal management. With long lifetimes also at high currents and superior corrosion resistance. OSCONIQ® P2226 Eco1's generate very little heat and therefore do not require any secondary heatsinking.

Colour Combination	Works For
Deep Blue + Hyper Red	Leafy greens such as lettuce and basil
Deep Blue + Hyper Red + Far Red	Leafy greens such as basil and aids in seed germination, stem elongation and leaf expansion
Deep Blue + Hyper Red + Yellow + Green	Flowering plants where biomass is the goal
White	Whites are added when the end application has no daylight, and these products offer the only source of useable wavelengths.

## Applications

- Horticultural Lighting
- General Lighting
- Decorative Lighting
- Task Lighting
- Spot Lighting
- Downlighters
- Retail and Entertainment Lighting
- Linear Lighting

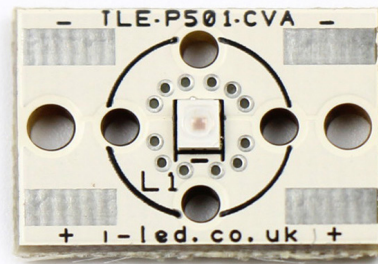

## Technical Features

- OSCONIQ® P2226 Eco1's contain OSCONIQ® P2226 LEDs from OSRAM Opto Semiconductors with integral 120 degree silicone resin Lens
- A secondary Lens can be fitted – check options in Lens and Reflector section
- Suitable Heatsinks available – check options in Heatsink section
- Suitable Power Supplies available - check options in Power Supply section
- Suitable Thermal Interface Material available - check options in Thermal Interface Material section
- Mounting holes using M3 screws allow easy installation
- Size (L x W x H): 20.25 x 13.70 x 3.05mm
- OSCONIQ® P2226 Eco1's can be linked together to produce longer chains
- Current range: 30-250mA

\*This datasheet should be read in conjunction with the relevant OSRAM Opto Semiconductor's for the LED used

## Important Information and Precautions

- The OSCONIQ® P2226 Eco1 Board when powered up, is very bright. Thus it is advised that you do not look directly at them. Turn the Eco1 away from you and do not shine into the eyes of others.
- Do not operate an OSCONIQ® P2226 with a power supply with unlimited current. Connection to constant voltage power supplies that are not current limited may cause the OSCONIQ® P2226 to consume current above the specified maximum and cause failure or irreparable damage.
- OSCONIQ® P2226 Eco1 board is a DOUBLE sided board for ease of connections, please ensure that one side is insulated to avoid shorting.
- DO NOT HOT PLUG ON LED SIDE OF POWER SUPPLY
- DO NOT TOUCH or PUSH on the LED as this might cause irreparable damage.

## Product Options

IHS Part Number	Colour	Wavelength *	Typical Wattage at 100mA §	Forward Voltage	Flux † at 100mA	Radiance Angle	Relevant OSRAM LED Datasheet
IHE-P201-DEBL-SC221.	Deep Blue	450nm	0.29W	2.6-3.4V	164.0mW	110°	GD DASPA2.14
IHE-P201-BLUE-SC221.	Blue	465nm	0.29W	2.8-3.0V	6.58lm	110°	GB DASPA2.13
IHE-P201-TRGR-SC221.	True Green	525nm	0.335W	3.2-3.6V	25.9lm	110°	GT DASPA2.13
IHE-P201-YELL-SC221.	Yellow	590nm	0.22W	1.8-2.4V	141.0m	110°	GY DASPA2.23
IHE-P201-RED1-SC221.	Red	618nm	0.21W	1.8-2.4V	211.0m	110°	GR DASPA2.23
IHE-P201-HYRE-SC221.	Hyper Red	640nm	0.215W	1.8-2.4V	104.0mW	110°	GH DASPA2.24
IHE-P201-FRED-SC221.	Far Red	730nm	0.18W	1.6-2.2V	56.0mW	110°	GF DASPA2.24

\* Due to the special conditions of the manufacturing processes of LEDs, the typical data of technical parameters can only reflect statistical figures and do not necessarily correspond to the actual parameters of each single product which could differ from the typical data.

§ Tolerance +/- 10%

† Measured with 10mS 100mA pulse at 25 °c

## Minimum and Maximum Ratings

IHS Part Number	Operating Temperature at Tc-Point [°C] *	Storage Temperature [°C] *	Forward Current per chip	Reverse Voltage [Vdc] *
IHE-P201-DEBL-SC221.	-40 ... 120 °C	40 ... 120 °C	250mA	1.2V
IHE-P201-BLUE-SC221.	-40 ... 120 °C	40 ... 120 °C	250mA	1.2V
IHE-P201-TRGR-SC221.	-40 ... 120 °C	40 ... 120 °C	250mA	1.2V
IHE-P201-YELL-SC221.	-40 ... 120 °C	40 ... 120 °C	250mA	1.2V
IHE-P201-RED1-SC221.	-40 ... 120 °C	40 ... 120 °C	250mA	1.2V
IHE-P201-HYRE-SC221.	-40 ... 120 °C	40 ... 120 °C	250mA	1.2V
IHE-P201-FRED-SC221.	-40 ... 120 °C	40 ... 120 °C	250mA	1.2V

\* Exceeding maximum ratings for operating and storage temperature will reduce expected life time or destroy the LED module. Exceeding maximum ratings for operating voltage will cause hazardous overload and is likely to destroy the LED module. The temperature of the LED module must be measured at the Tc-Point according to EN60598-1 in a thermally constant status with a temperature sensor or a temperature sensitive label.

Radiation of single LED

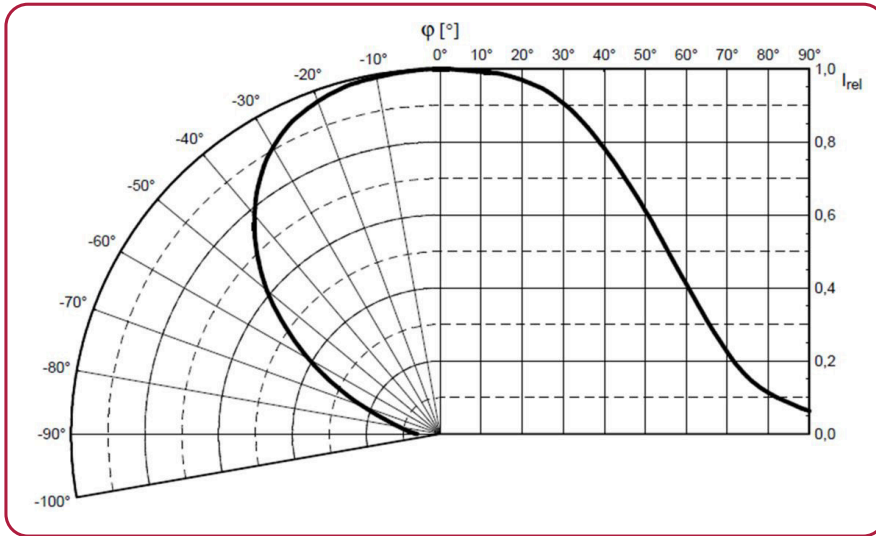

Technical Drawing (mm)

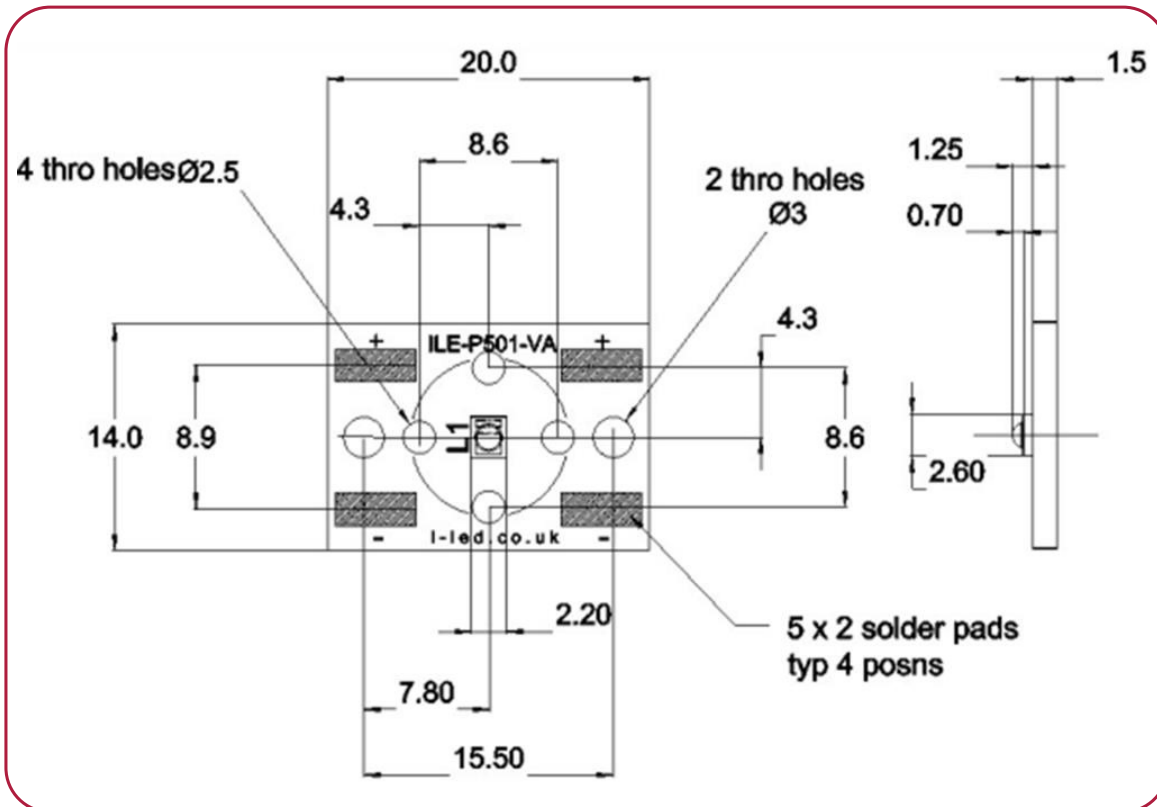

3D drawing files are available on request from IHS. Please call or email

**OSCONIQ® P2226 Eco1 Lens and Reflector Options**

LEDiL precision-engineered Lenses and Reflectors allow for rapid deployment of all types of light fixtures, including street lights, wall-wash, high-bay, sconces, emergency beacons, parking garage/low-bay, MR and AR down lights, and dock lights. Precision-engineered for maximum efficiency and durability, LEDiL Lenses and Reflectors are released alongside the latest product releases from our LED suppliers. You select the best LED for the application; choose LEDiL and you're selecting the best optical solution as well.



Ordering Code	Beam	Dimensions	Height	Family	FWHM	Material	Colour	Fastening
C12469_LISA2-R-PIN	Wide	10mm	6.6mm	Lisa2	80°	PMMA+PC	Black	Pin+Glue
FP10992_LISA2-M-PIN	Medium	10mm	6.6mm	Lisa2	20°	PMMA+PC	Black	Pin+Glue
FP10993_LISA2-W-PIN	Wide	10mm	6.6mm	Lisa2	35°	PMMA+PC	Black	Pin+Glue
FP10997_LISA2-WW-PIN	Wide	10mm	6.6mm	Lisa2	45°	PMMA+PC	Black	Pin+Glue
FP11047_LISA2-RS-PIN	Spot	10mm	6.6mm	Lisa2	19°	PMMA+PC	Black	Pin+Glue
FP11075_LISA2-M-CLIP	Medium	10mm	6.6mm	Lisa2	20°	PMMA+PC	Black	Pin+Glue
FP11076_LISA2-W-CLIP	Wide	10mm	6.6mm	Lisa2	35°	PMMA+PC	Black	Clips
FP11077_LISA2-WW-CLIP	Wide	10mm	6.6mm	Lisa2	45°	PMMA+PC	Black	Clips
FP11085_LISA2-RS-CLIP	Spot	10mm	6.6mm	Lisa2	19°	PMMA+PC	Black	Clips
FP11120_LISA2-O-CLIP	Oval	10mm	6.6mm	Lisa2	45x20°	PMMA+PC	Black	Clips
FP11429_LISA2-WWW-CLIP	Wide	10mm	6.6mm	Lisa2	80°	PMMA+PC	Black	Clips
FP16558_LISA3-RS-PIN	Spot	10mm	7.9mm	Lisa3	15°	PMMA+PC	Black	Pin+Glue
FP16559_LISA3-M-PIN	Medium	10mm	7.9mm	Lisa3	25°	PMMA+PC	Black	Pin+Glue
FP16560_LISA3-W-PIN	Wide	10mm	7.9mm	Lisa3	35°	PMMA+PC	Black	Pin+Glue
FP16561_LISA3-WW-PIN	Wide	10mm	7.9mm	Lisa3	45°	PMMA+PC	Black	Pin+Glue
FP16562_LISA3-WWW-PIN	Wide	10mm	7.9mm	Lisa3	60°	PMMA+PC	Black	Pin+Glue
FP16563_LISA3-O-PIN	Oval	10mm	7.9mm	Lisa3	18x50°	PMMA+PC	Black	Pin+Glue







**OSCONIQ® P2226 Eco1 Heatsink Options**

IHS has a series of Aluminium Alloy Heatsinks to be used with our standard range of PowerStars, PowerClusters and PowerLinear Engines. These Heatsinks are supplied with fixing screws for the light engine and for fixing to a base plate. They also come with Thermal Interface Material (TIM) attached to the top surface. IHS is continually expanding its Heatsink range and we are equally happy to manufacture custom Heatsinks upon your request.

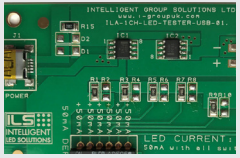
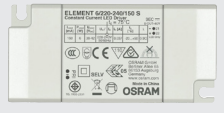
This product would not normally require a Heatsink as heat generated will typically be minimal.

## OSCONIQ® P2226 Eco1 Power Supply Options

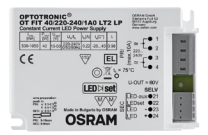
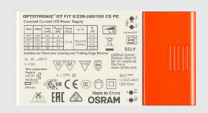
IHS has a comprehensive range of standard Power Supplies. The table below shows forward voltage of each LED driver please consult the product options table to find the forward voltage of the LEDiL Selector used. Additional Power Supplies are being introduced so please call us or check our website for the latest offering.

IHS Driver Part Number	Rating (Watts)	Constant Current Output	Forward Voltage	
ILA-1CH-LED-TESTER-USB-01.	2W	50 - 350mA	5V	
ELEMENT-LD-8/220-240/180	8W	180mA	21-42V	
ELEMENT-6/220-240/150-S	6W	150Ma	30-42V	
ELEMENT-8/220-240/200-S	8W	200Ma	30-42V	
ELEMENT-10/220-240/250-S	10W	250Ma	30-42V	
OT-FIT-20/220-240/500-CS-G2	20W	250-500mA	25-42V	
OT-FIT-8/220-240/180-CS-S-MINI	8W	90-180mA	30-42V	
OT-FIT-15/220-240/500-LT2-LP	15W	150-500mA	15-50V	
OT-FIT-8/220-240/180-CS-PC-SC	8W	100-180mA	27-40	
OTi-DALI-10/220-240/700-NFC	10W	150-700mA	2.5-45V	

## OSCONIQ® P2226 Eco1 Thermal Interface Material Options

IHS has produced a range of high-performance, cost effective Thermal Interface Materials to match perfectly their standard products. Our product fills the air pockets between the two surfaces, forming a continuous layer to conduct heat away from the LED to the Heatsink. As the Eco1 generates little heat, TIM is therefore not needed. Our double sided thermal tape would be suitable for fixing the Eco1 to a fixture, Heatsink and flat substrate.

Product	Non Adhesive	Single Sided Adhesive	Double Sided Adhesive
OSCONIQ® P2226 Eco1	N/A	N/A	ILA-TIM-ECO1-2A

Other sizes are available, including customised parts

## Assembly Information

- In order to optimise the thermal management, the metal surface needs to be clean (dirt and oil free) and planar for the best contact with the LED module. A thermal grease or heat transfer material is highly recommended.

## Safety Information

- The LED module itself and all its components must not be mechanically stressed.
- Assembly must not damage or destroy conducting paths on the circuit board.
- The mounting of the module is carried out by attaching it at the mounting holes. Metal mounting screws must be insulated with synthetic washers to prevent circuit board damage and possible short circuiting.
- To avoid mechanical damage to the connecting cables, the boards should be attached securely to the intended substrate. Heavy vibration should be avoided.
- Observe correct polarity!
- Depending on the product, incorrect polarity will lead to emission of red or no light. The module can be destroyed!
- Pay attention to standard ESD precautions when installing the OSCONIQ® P2226 Eco1.
- The OSCONIQ® P2226 Eco1, as manufactured, has no conformal coating and therefore offer no inherent protection against corrosion.
- Damage by corrosion will not be accepted as a materials defect claim. It is the user's responsibility to provide suitable protection against corrosive agents such as moisture and condensation and other harmful elements.
- For outdoor usage, a housing is definitely required to protect the board against environmental influences. The design of the housing must correspond to the IP standards in the application. It is also the responsibility of the user to ensure any housings or modifications keep the Tc junction temperature to within stated ranges.
- To also ease the luminaire/installation approval, electronic control gear for LED or LED modules should carry the CE mark and be ENEC certified. In Europe the declarations of conformity must include the following standards: CE: EC 61374-2-13, EN 55015, IEC 61547 and IEC 61000-3-2 - ENEC: 61374-2-13 and IEC/EN 62384.
- The evaluation of eye safety occurs according to the standard IEC 62471:2006 ("photobiological safety of lamps and lamp systems"). Within the risk grouping system of this CIE standard, the LED specified in this data sheet falls into the class "moderate risk" (exposure time 0.25s). Under real circumstances (for exposure time, eye pupils, observation distance), it is assumed that no endangerment to the eye exists from these devices. As a matter of principle, however, it should be mentioned that intense light sources have a high secondary exposure potential due to their blinding effect. As is also true when viewing other bright light sources (e.g. headlights), temporary reduction in visual acuity and afterimages can occur, leading to irritation, annoyance, visual impairment and even accidents, depending on the situation.

# www.i-hled.co.uk

## For further information please contact IHS

The values contained in this datasheet can change due to technical innovations. Any such changes will be made without separate notification.