

F9000 series, maxiOTO blade fuse

- Meets international specs, complies to DIN ISO 8820-3, SAE J1888 and other standards
- Element visibility from side, clear transparent fuse body
- Check fuse in fuse block using semi-protected test points at top of the fuse
- Blade rigidity through robust/sturdy body construction
- Safe and highly reliable/consistent operation with a single piece construction
- Self extinguishing transparent, color coded body materials
- High temperature resistive plastics used for fuse body materials
- Secure and reliable time-delayed functioning with purpose designed element shapes
- Direction insensitive insertion, rating marked in two directions at top, using OCR font

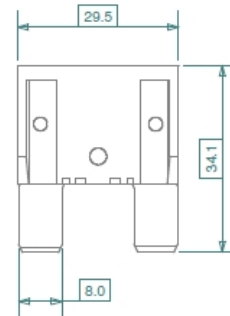

iMaXX ref.	Color	Rating [A]	Voltage [V]
F9020	Yellow	20	32
F9025	Grey	25	32
F9030	Green	30	32
F9040	Orange	40	32
F9050	Red	50	32
F9060	Blue	60	32
F9070	Brown	70	32
F9080	Natural	80	32
F9100	Violet	100	32



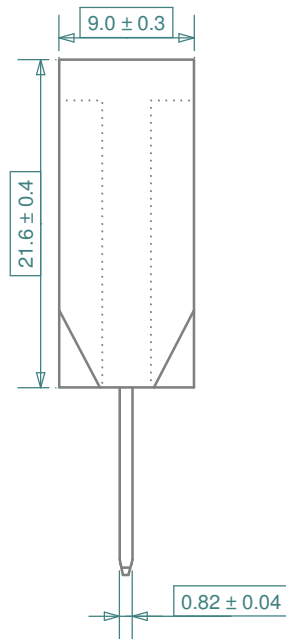
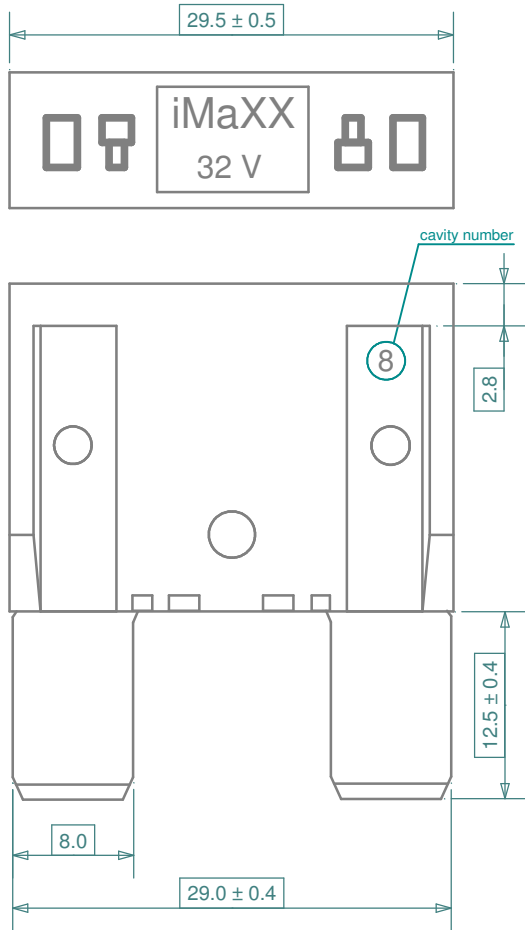

Fusing time DIN ISO 8820-3 [s]		
Load [%]	Minimum [s]	Maximum [s]
100 %	360,000	-
135 %	60	900
160 %	10	200
200 %	2	60
350 %	0.2	7
600 %	0.04	1

Rating [A]	Color	Volt [V]	iMaXX Reference
20	Yellow	32	F9020
25	Grey	32	F9025
30	Green	32	F9030
40	Orange	32	F9040
50	Red	32	F9050
60	Blue	32	F9060
70	Brown	32	F9070
80	Natural	32	F9080
100	Violet	32	F9100

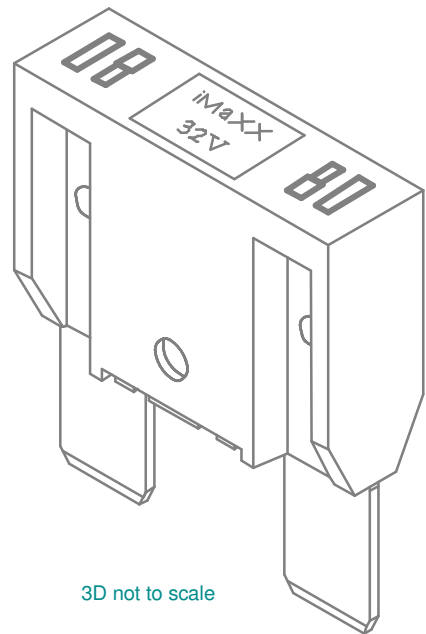

Revisions			Date	Appr.	
	Date	Type	Drawn	08/00	GRH
a	07/01	DIN nomenclature	Checked	10/12	EB
b	07/07	re-drawn	Standards		
c	07/10	corrected DIN dimension spec	Approved	10/12	AdH
d	12/10	added 25 amp			
e	07/11	updated DIN to ISO & add cavity #	Scale 2 : 1		
f	10/12	updated dimensions	Projection	Tolerance	
				± 0.2 mm unless otherwise noted	

		Title	F9000 series, maxiOTO blade fuse
		Drawing type	schematic
		Drawing number	F9000 drawing 1
		Sheet	1 of 1
Layers	0 1 2 6 9 11		

