



Main

Range compatibility	Lexium 28
Product or component type	Servo motor
Device short name	BCH2

Complementary

Maximum mechanical speed	5000 rpm
[Us] rated supply voltage	220 V
Network number of phases	Single phase Three phase
Continuous stall current	1.11 A
Continuous stall torque	0.64 N.M for LXM26D at 1.5 A, 220 V, single phase 0.64 N.M for LXM26D at 1.5 A, 220 V, three phase 0.64 N.M for LXM28... at 1.5 A, 220 V, single phase 0.64 N.M for LXM28... at 1.5 A, 220 V, three phase 0.64 N.m for LXM28... at 3.6 A, 110 V, single phase
Continuous power	200 W
Peak stall torque	1.92 N.M for LXM26D at 1.5 A, 220 V, single phase 1.92 N.M for LXM26D at 1.5 A, 220 V, three phase 1.92 N.M for LXM28... at 1.5 A, 220 V, single phase 1.92 N.M for LXM28... at 1.5 A, 220 V, three phase 1.92 N.m for LXM28... at 3.6 A, 110 V, single phase
Nominal output power	200 W for LXM26D at 1.5 A, 220 V, single phase 200 W for LXM26D at 1.5 A, 220 V, three phase 200 W for LXM28... at 1.5 A, 220 V, single phase 200 W for LXM28... at 1.5 A, 220 V, three phase 200 W for LXM28... at 3.6 A, 110 V, single phase
Nominal torque	0.64 N.M for LXM26D at 1.5 A, 220 V, single phase 0.64 N.M for LXM26D at 1.5 A, 220 V, three phase 0.64 N.M for LXM28... at 1.5 A, 220 V, single phase 0.64 N.M for LXM28... at 1.5 A, 220 V, three phase 0.64 N.m for LXM28... at 3.6 A, 110 V, single phase
Nominal speed	3000 rpm for LXM26D at 1.5 A, 220 V, single phase 3000 rpm for LXM26D at 1.5 A, 220 V, three phase 3000 rpm for LXM28... at 1.5 A, 220 V, single phase 3000 rpm for LXM28... at 1.5 A, 220 V, three phase 3000 rpm for LXM28... at 3.6 A, 110 V, single phase
Maximum current Irms	4.31 A for LXM28... at 0.2 kW, 220 V 4.31 A for LXM28... at 0.2 kW, 110 V
Maximum permanent current	1.3 A
Product compatibility	LXM26D servo drive motor at 0.2 kW, 220 V, single phase LXM26D servo drive motor at 0.2 kW, 220 V, three phase LXM28... servo drive motor at 0.2 kW, 220 V, single phase LXM28... servo drive motor at 0.2 kW, 220 V, three phase LXM28... servo drive motor at 0.2 kW, 110 V, single phase
Shaft end	Keyed
Shaft diameter	14 mm
Shaft length	30 mm

Key width	5 mm
Feedback type	20 bits single turn absolute encoder
Holding brake	Without
Mounting support	Asian standard flange
Motor flange size	60 mm
Electrical connection	Free lead
Torque constant	0.58 N.m/A at 20 °C
Back emf constant	35 V/krpm at 20 °C
Rotor inertia	0.16 kg.cm ²
Stator resistance	12.2 Ohm at 20 °C
Stator inductance	22.5 mH at 20 °C
Stator electrical time constant	1.84 ms at 20 °C
Maximum radial force Fr	200 N at 3000 rpm
Maximum axial force Fa	70 N
Brake pull-in power	11.2 W
Type of cooling	Natural convection
Length	104 mm
Number of motor stacks	1
Centring collar diameter	50 mm
Centring collar depth	5.5 mm
Number of mounting holes	4
Mounting holes diameter	5.5 mm
Circle diameter of the mounting holes	70 mm
Distance shaft shoulder-flange	5.5 mm
Net weight	1.02 kg

Environment

IP degree of protection	IP50 IM V3 IP65 IM B5, IM V1
Ambient air temperature for operation	-20...40 °C

Packing Units

Unit Type of Package 1	PCE
Number of Units in Package 1	1
Package 1 Weight	1.461 kg
Package 1 Height	11.484 cm
Package 1 width	14.736 cm
Package 1 Length	26.812 cm
Unit Type of Package 2	S06
Number of Units in Package 2	40
Package 2 Weight	67.0 kg
Package 2 Height	73.5 cm
Package 2 width	60.0 cm
Package 2 Length	80.0 cm

Offer Sustainability

Sustainable offer status	Green Premium product
REACH Regulation	REACH Declaration
REACH free of SVHC	Yes
EU RoHS Directive	Pro-active compliance (Product out of EU RoHS legal scope) EU RoHS Declaration
Mercury free	Yes
RoHS exemption information	Yes
China RoHS Regulation	China RoHS Declaration

Environmental Disclosure	Product Environmental Profile
Circularity Profile	End Of Life Information
WEEE	The product must be disposed on European Union markets following specific waste collection and never end up in rubbish bins
PVC free	Yes

Contractual warranty

Warranty	18 months
----------	-----------

Dimensions

Dimensions of Motor

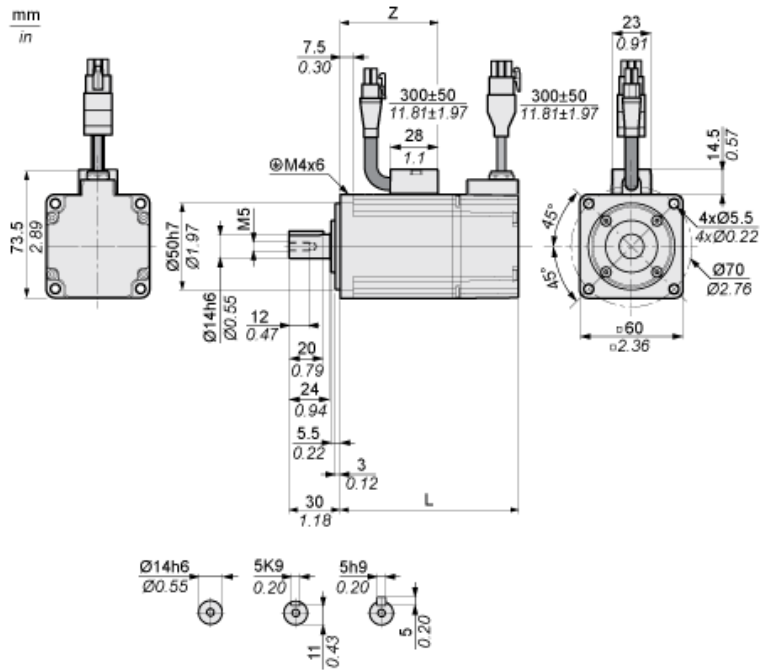

	mm	in.
L (without holding brake)	104	4.09
L (with holding brake)	140	5.51
Z	57	2.24

Torque/Speed Curves with 230 V Single/Three Phase Supply Voltage

Servo Motor with LXM28AU02●●● Servo Drive

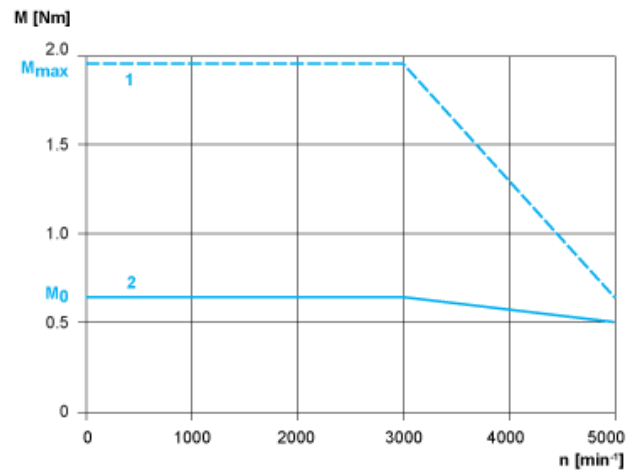

- 1 : Peak torque
- 2 : Continuous torque