

## 5mm T-1 3/4 Ambient Light Sensor

ALS-PDIC243-3B

### Features

- Excellent IR-Cut performance
- Close responsively to the human eye spectrum
- Light to Current, analog output
- Good output linearity across wide illumination range
- Low sensitivity variation across various light sources
- Operation temperature performance, -40°C to 85°C
- Wide supply voltage range, 1.8V to 5.5V
- Size: 5mm Lamp (Flat lens)
- RoHS compliant package



### Description

The ALS-PDIC243-3B is an ambient light sensor, which incorporates a photodiode and a current amplifier IC in DIP package. EVERLIGHT ALS series products are a good effective solution to the power saving of display backlighting of mobile appliances, such as the mobile phones, NB and PDAs. Due to the high rejection ratio of infrared radiation, the spectral response of the ambient light sensor is close to human eyes. Also, it is very suitable to use ALS product for opto-switch application.

### Applications

- Ambient light monitoring device for daylight and artificial light
  - CCD camera/CCTV security equipment, Street light
- Detection of ambient light to control display backlighting
  - Computing device – TFT LCD monitor for Notebook computer
  - Consumer device – TFT LCD TV, video camera, digital camera, toys

## 5mm T-1 3/4 Ambient Light Sensor

ALS-PD1C243-3B

### Package Dimensions

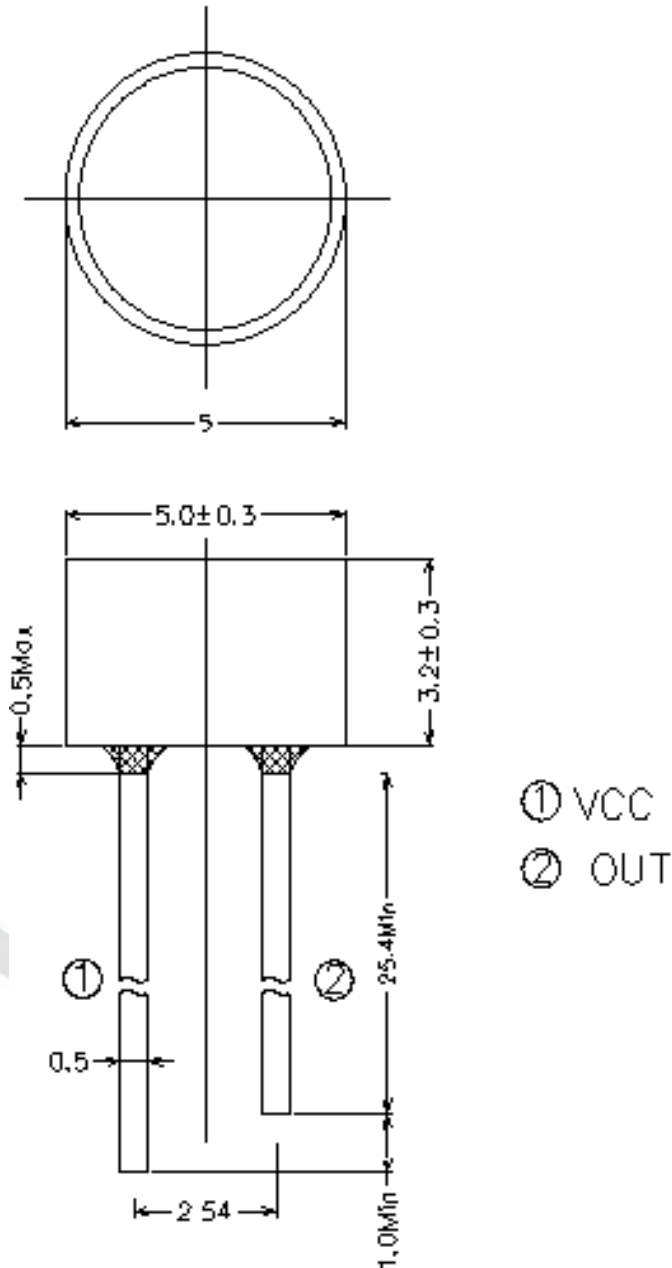

- Notes:** 1.All dimensions are in millimeters  
2.Tolerances unless dimensions  $\pm 0.1\text{mm}$

## 5mm T-1 3/4 Ambient Light Sensor

ALS-PDIC243-3B

### Absolute Maximum Ratings (Ta=25 )

Parameter	Symbol	Rating	Unit
Supply Voltage	V <sub>cc</sub>	-0.7~6.5	V
Operating Temperature Range	T <sub>opr</sub>	-40 ~ +85	°C
Storage Temperature Range	T <sub>stg</sub>	-40 ~ +100	°C
Soldering Temperature Range	T <sub>sol</sub>	260	°C

### Recommended Operating Conditions (Ta=25 )

Parameter	Symbol	Min.	Max.	Unit
Operating Temperature	T <sub>opr</sub>	-40	+85	°C
Supply Voltage	V <sub>cc</sub>	1.8	5.5	V

### Rankings

BIN	Symbol	Min.	Max.	Unit	Test Condition
1	I <sub>ph2</sub>	10	16	uA	V <sub>cc</sub> =3V E <sub>v</sub> = 100Lux
2	I <sub>ph2</sub>	14	23	uA	
3	I <sub>ph2</sub>	20	30	uA	
4	I <sub>ph2</sub>	26	35	uA	

## 5mm T-1 3/4 Ambient Light Sensor

ALS-PD1C243-3B

### Electrical and Optical Characteristics (Ta=25 )

Parameter	Symbol	MIN	TYP	MAX.	Unit	Test Condition
Dark Current	$I_D$	---	0.05	0.1	uA	$V_{CC}=3V, E_v=0Lux$
Light Current	$I_{PH1}$	1	---	3.5	uA	$V_{CC}=3V, E_v=10Lux$ [Note1]
	$I_{PH2}$	10	---	35	uA	$V_{CC}=3V, E_v=100Lux$ [Note1]
	$I_{PH3}$	100	---	350	uA	$V_{CC}=3V, E_v=1000Lux$ [Note1]
	$I_{PH4}$	100	300	---	uA	$V_{CC}=3V, E_v=1000Lux$ [Note2]
Photocurrent Ratio	$I_{PH4} / I_{PH3}$	---	1.2	---	---	$V_{CC}=3V, E_v=1000Lux$
Peak Sensitivity Wavelength	$\lambda_p$	---	560	---	nm	---
Sensitivity Wavelength Range	$\lambda$	390	---	700	nm	---
Rise time	$t_r$	---	0.36	---	ms	$V_{CC} = 3 V$ $R_L = 27K\Omega$
Fall time	$t_f$	---	1.13	---	ms	
Angle of half Sensitivity	$2\theta_{1/2}$	---	143	---	Deg.	$V_{CC} = 3 V$

Note:

- White Fluorescent light (Color Temperature = 6500K) is used as light source. However, White LED is substituted in mass production.
- Illuminance by CIE standard illuminant-A / 2856K, incandescent lamp.

### Typical Electrical and Optical Characteristics Curves

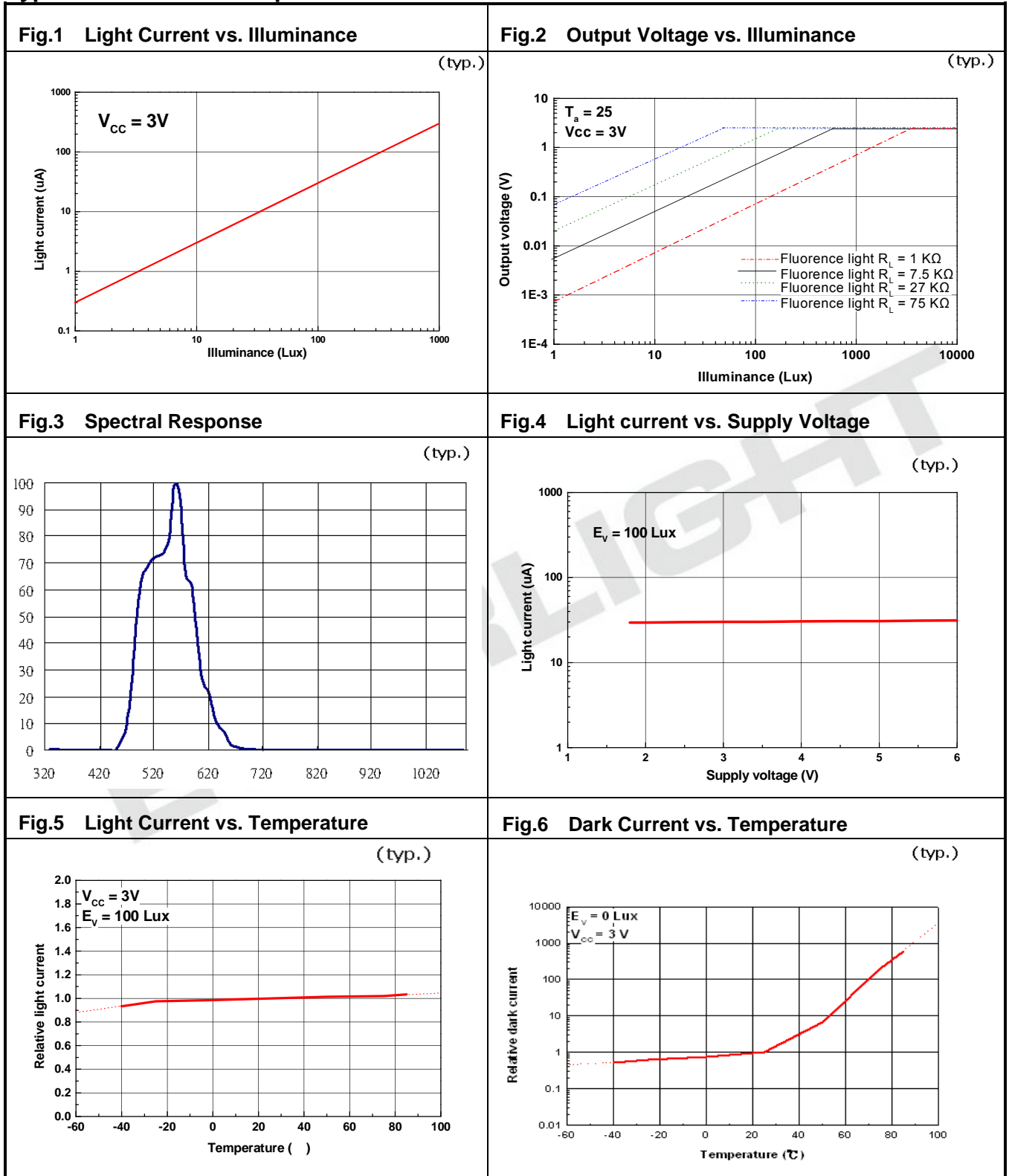

## Converting Photocurrent to Voltage

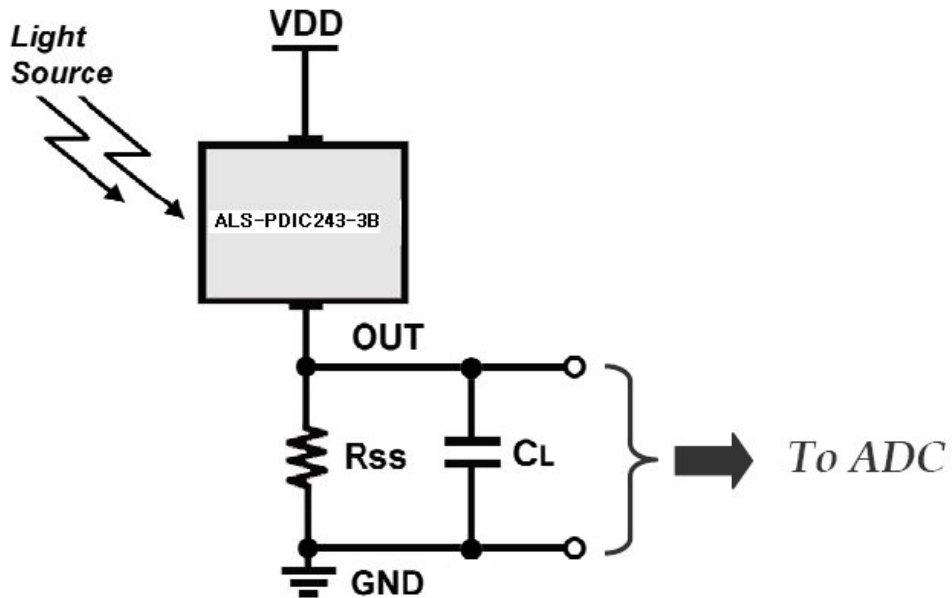

Note:

1. The output voltage ( $V_{out}$ ) is the product of photocurrent ( $I_{PH}$ ) and loading resistor ( $R_L$ )
2. A right loading resistor shall be chosen to meet the requirement of maximum ambient light, and output saturation voltage:

$$V_{out(max.)} = I_{out(max.)} \times R_L \quad V_{out(saturation)} = V_{cc} - 0.4V$$

## 5mm T-1 3/4 Ambient Light Sensor

ALS-PD1C243-3B

### Packing Quantity Specification

1.500PCS/1Bag , 5Bags/1Box

2.10Boxes/1Carton

### Label Format



EVERLIGHT

10

CPN:



P/N:



RoHS

QTY:



LOT NO:



Reference:



CAT:

HUE:

REF:

CPN: Customer's Production Number

P/N : Production Number

QTY: Packing Quantity

CAT: Ranks

HUE: Peak Wavelength

REF: Reference

LOT No: Lot Number

## Note

1. Above specification may be changed without notice. EVERLIGHT will reserve authority on material change for above specification.
2. When using this product, please observe the absolute maximum ratings and the instructions for using outlined in these specification sheets. EVERLIGHT assumes no responsibility for any damage resulting from use of the product which does not comply with the absolute maximum ratings and instructions included in these specification sheets.
3. These specification sheets include materials protected under copyright of EVERLIGHT corporation. Please don't reproduce or cause anyone to reproduce them without EVERLIGHT's consent.

EVERLIGHT