



FASTIN-FASTON | FASTIN-FASTON 110

TE Internal #: 928930-5

FASTIN-FASTON 110, Quick Disconnects, Tab, 20 – 17 AWG Wire Size, .5 – 1 mm² Wire Size, 1021 – 2048 CMA Wire Size, Mating Tab Width .11 in [2.8 mm]

[View on TE.com >](#)

Terminals & Splices > Quick Disconnects



Quick Disconnect Terminal Type: **Tab**

Wire Size: **1021 – 2048 CMA**

Mating Tab Width: **2.8 mm [.11 in]**

Features

Product Type Features

Terminates To	Wire & Cable
Wire/Cable Type	Regular Wire
Sealable	No

Configuration Features

Connection Capacity	Single
---------------------	--------

Contact Features

Quick Disconnect Terminal Type	Tab
Mating Tab Width	2.8 mm [.11 in]
Mating Tab Thickness	.79 mm [.031 in]
Terminal Orientation	Straight
Contact Base Material	Copper Tin Alloy
Terminal Plating Material	Pre-Tin
Crimp Type	F-Crimp
Barrel Type	Open

Mechanical Attachment



Mating Retention Type	Locking Lance
Locking Lance Height	1.2 mm[.047 in]

Dimensions

Accepts Wire Insulation Diameter Range	1.4 – 2.3 mm[.055 – .09 in]
Overall Length	22.5 mm[.886 in]
Wire Size	1021 – 2048 CMA

Usage Conditions

Insulation Requirement	Uninsulated
Operating Temperature Range	-40 – 130 °C[-40 – 266 °F]

Packaging Features

Packaging Quantity	4000
Packaging Method	Reel

Product Compliance

[For compliance documentation, visit the product page on TE.com>](#)

EU RoHS Directive 2011/65/EU	Compliant
EU ELV Directive 2000/53/EC	Compliant
China RoHS 2 Directive MIIT Order No 32, 2016	No Restricted Materials Above Threshold
EU REACH Regulation (EC) No. 1907/2006	Current ECHA Candidate List: JAN 2022 (223) Candidate List Declared Against: JAN 2022 (223) Does not contain REACH SVHC
Halogen Content	Low Halogen - Br, Cl, F, I < 900 ppm per homogenous material. Also BFR/CFR/PVC Free
Solder Process Capability	Not applicable for solder process capability

Product Compliance Disclaimer

This information is provided based on reasonable inquiry of our suppliers and represents our current actual knowledge based on the information they provided. This information is subject to change. The part numbers that TE has identified as EU RoHS compliant have a maximum concentration of 0.1% by weight in homogenous materials for lead, hexavalent chromium, mercury, PBB, PBDE, DBP, BBP, DEHP, DIBP, and 0.01% for cadmium, or qualify for an exemption to these limits as defined in the Annexes of Directive 2011/65/EU (RoHS2). Finished electrical and electronic equipment products will be CE marked as required by Directive 2011/65/EU. Components may not be CE marked. Additionally, the part numbers that TE has identified as EU ELV compliant have a maximum concentration of 0.1% by weight in homogenous materials for lead, hexavalent chromium, and mercury, and 0.01% for cadmium, or qualify for an exemption to these limits as defined in the Annexes of Directive 2000/53/EC (ELV). Regarding the REACH Regulation, the information TE provides on SVHC in articles for this part number is based on the latest European Chemicals Agency (ECHA) 'Guidance on requirements for substances in articles' posted at this URL: <https://echa.europa.eu/guidance-documents/guidance-on-reach>

Compatible Parts



TE Part # CAT-T4827-CH8172
TIMER, CONNECTOR HOUSING



TE Part # 1-1579007-4
EXTRACTION TOOL



TE Part # 4-1579007-3
EXTRACTION TOOL KIT

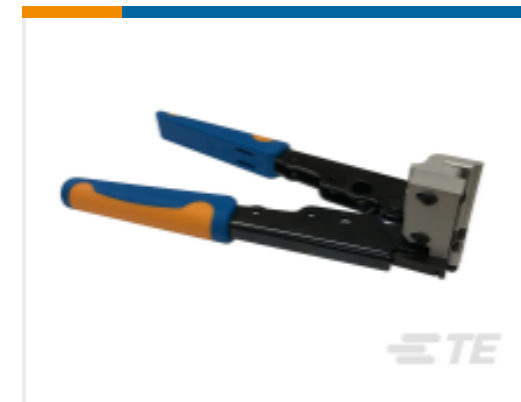

TE Part # 2305570-1
TERMINAL CUTTER, SIDE FEED



TE Part # 2-2151379-1
OCEAN_2.0_Applicator-S-080F110OV



TE Part # 2-2151379-2
OCEAN_2.0_Applicator-S-080F110OV



TE Part # 2151379-1
OCEAN_2.0_Applicator-S-080F110OV



TE Part # 2151379-2
OCEAN_2.0_Applicator-S-080F110OV



TE Part # 7-2151379-1
OCEAN_2.0_Applicator-S-080F110OV



TE Part # 7-2151379-2
OCEAN_2.0_Applicator-S-080F110OV

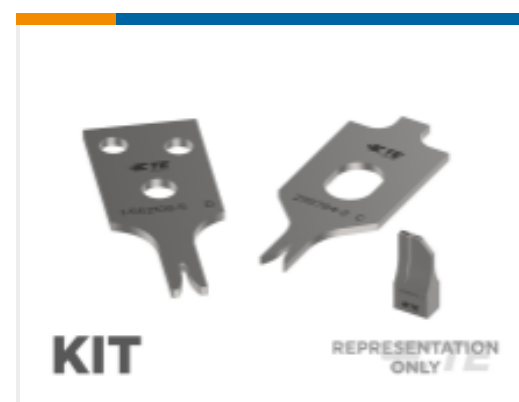

TE Part # 7-2151379-7
OCEAN_2.0_SPARE_PART_KIT-080F110OV

Also in the Series | FASTIN-FASTON 110



Automotive Housings(1)

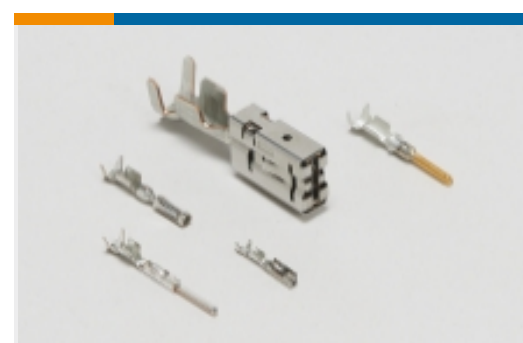

Automotive Terminals(4)



Crimp Terminal Housings(34)



Insertion & Extraction Tools(3)



Quick Disconnects(84)

Customers Also Bought

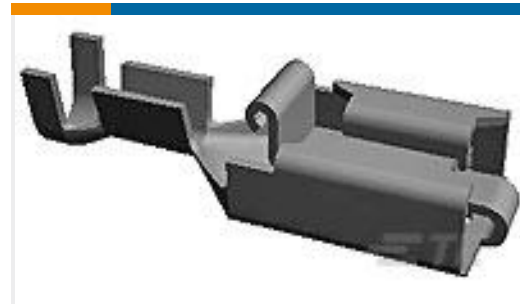
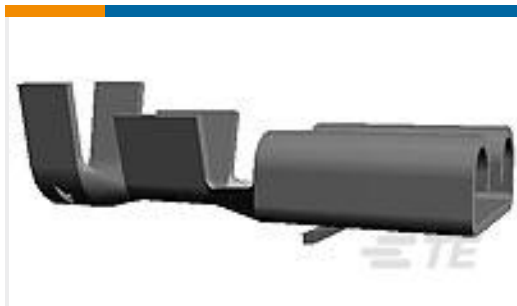
TE Part #180351-8
FF 250 REC 4-6MM2 PTBRTE Part #927852-7
PL 250 REC TERMINAL 20-17 AWG
PTPPBTE Part #1-965640-6
JUN-POW-TIM GEH 6PTE Part #925595-2
TIMER, RECEPTACLE AND TABTE Part #5-160446-2
FF 250 REC 1.0-2.5MM2 TPPBTE Part #3-1904131-5
V23134A4052X544-EV-CBOXTE Part #0838016008
RBK-VWS-125-NR1-X-25MMTE Part #3257456011
RBK-VWS-125-NR2-X-35MM

Documents

Product Drawings

FF 110 TAB 0.5-1 MM2 .080 F PTP CUZN30

English

CAD Files

3D PDF

3D

Customer View Model

[ENG_CVM_CVM_928930-5_P.2d_dxf.zip](#)

English

Customer View Model

[ENG_CVM_CVM_928930-5_P.3d_igs.zip](#)

English

Customer View Model

[ENG_CVM_CVM_928930-5_P.3d_stp.zip](#)

English

By downloading the CAD file I accept and agree to the [Terms and Conditions](#) of use.



Product Specifications

2,8 mm Flachstecker

English

Application Specification

English

Product Environmental Compliance

Product Compliance

English

Product Compliance

English