



Beacon series R

Auer Signal

-30°C to +60°C (-22°F to +140°F)



	WARNING	Disconnect from power source to prevent electrical shock before installing or servicing. Check power supply voltage and frequency.
	AVERTISSEMENT	Déconnecter l'alimentation avant toute opération d'installation ou de maintenance, afin d'éviter les décharges électriques. Contrôler la tension et la fréquence d'alimentation.
	WARNUNG	Schalten Sie den Strom während der Installation oder bei Wartungsarbeiten ab um einen elektrischen Schlag zu vermeiden. Prüfen Sie die Spannung und Frequenz der Stromquelle.
	AVVERTENZA	Scolligare dall'alimentazione prima dell'installazione e della messa in servizio. Controllare la tensione di alimentazione e la frequenza.
	ATENÇÃO	Desligar a alimentação antes de realizar qualquer intervenção. Verificar a tensão e frequência da alimentação.
	ADVERTENCIA	Durante el proceso de instalación o mantenimiento desconectar la tensión de alimentación para evitar descargas eléctricas. Comprobar tensión y frecuencia de alimentación.

RBA

IP66
UL Type 4,4X,13

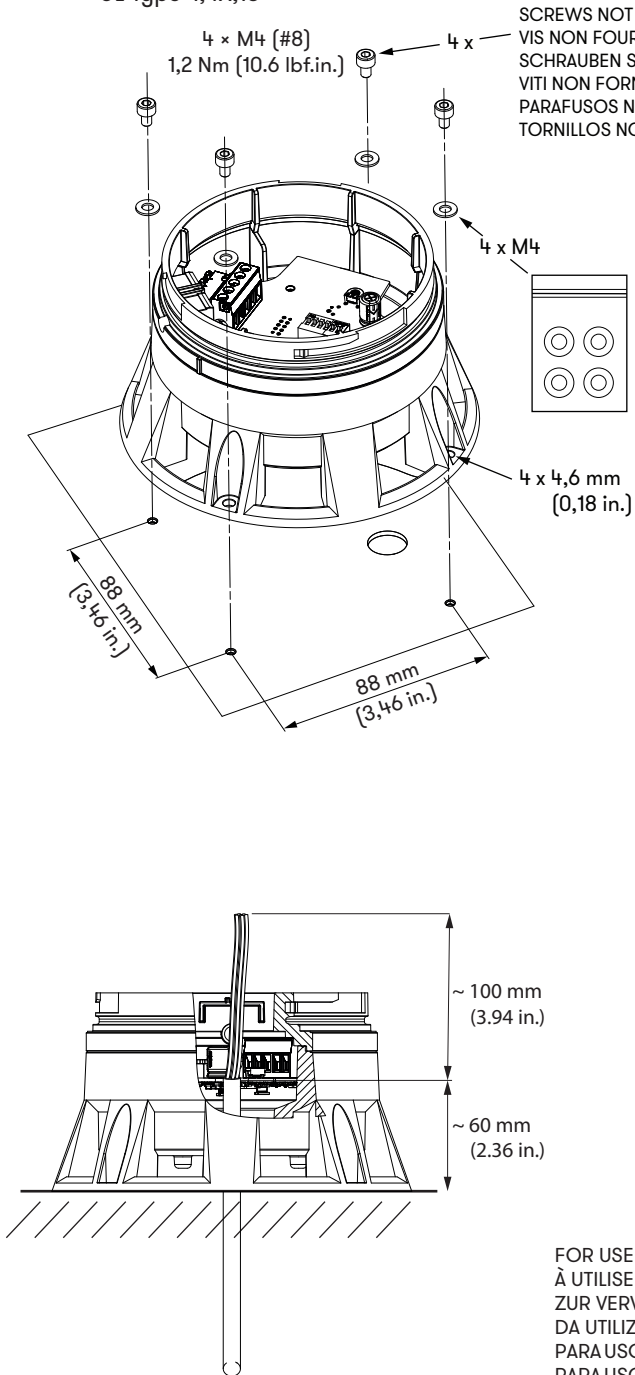

SCREWS NOT SUPPLIED
VIS NON FOURNIES
SCHRAUBEN SIND NICHT ENTHALTEN
VITI NON FORNITE
PARAFUSOS NÃO INCLUIDOS
TORNILLOS NO SUMINISTRADOS

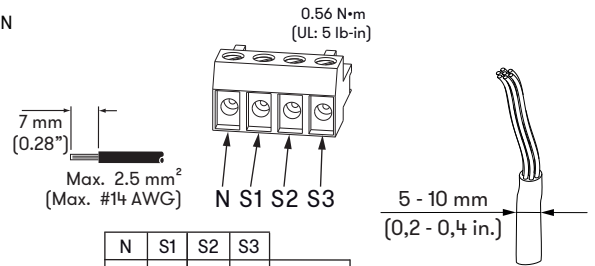

N	S1	S2	S3	
N	L			Stage 1
N	x	L		Stage 2
N	x	x	L	Stage 3

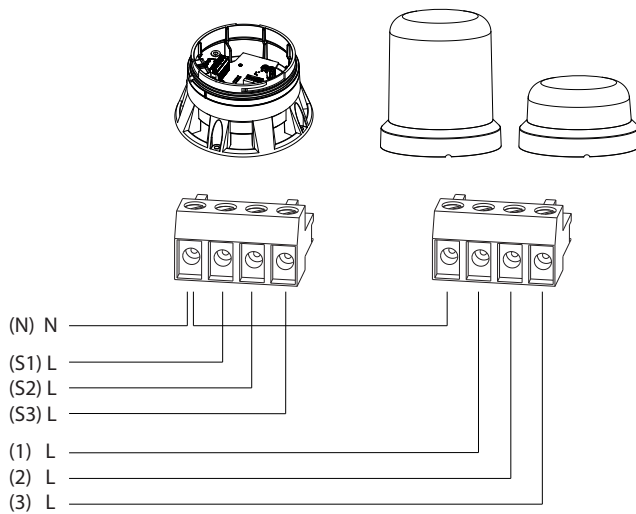

FOR USE ON A FLAT RIGID SURFACE OF INDICATED TYPE ENCLOSURE
À UTILISER SURUNE SURFACEPLANEDE L'ENCEINTE DU TYPE INDIQUÉ
ZUR VERWENDUNG AUF EINER FLACHEN OBERFLÄCHE DES ANGEGEBENEN GEHÄUSETYP
DA UTILIZZARE SU UNA SUPERFICIE PIANA DEL TIPO DI CUSTODIA INDICATO
PARA USO SOBRE LA SUPERFICIE PLANA DE UN ENVOLVENTE DEL TIPO INDICADO
PARA USO EM SUPERFÍCIE PLANA NO TIPO DE PROTEÇÃO INDICADA

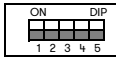

Tone table

Dip switch	Stage 1	Tone type	Frequency	Pictogram	Repeat rate	Typical application	Stage 2	Stage 3
	Tone 01	continuous	660 Hz			Swedish alarm	Tone 16	Tone 12
	Tone 02	continuous	1000 Hz			PFEER toxic gas	Tone 16	Tone 25
	Tone 03	continuous	2400 Hz				Tone 21	Tone 17
	Tone 04	intermittent	420 Hz		0,625 s on / 0,625 s off	Australian alert AS1670	Tone 21	Tone 01
	Tone 05	intermittent	660 Hz		1,8 s on - 1,8 s off	Swedish alarm	Tone 21	Tone 01
	Tone 06	intermittent	660 Hz		0,15 s on / 0,15 s off	Swedish alarm	Tone 16	Tone 01
	Tone 07	intermittent	970 Hz		1 s on, 1 sec off	PFEER Alarm, BS5839-1:2002	Tone 18	Tone 01
	Tone 08	intermittent	970 Hz (950)		0,5 s on/0,5 s off x 3 then 1 s off	ISO 8201 low tone, US Temporal	Tone 16	Tone 03
	Tone 09	intermittent	800 Hz		0,25 s on / 1 s off		Tone 27	Tone 03
	Tone 10	intermittent	700 Hz		0,15 s on / 0,15 s off, total 1 min.	Swedish alarm SS 031711	Tone 18	Tone 02
	Tone 11	intermittent	720 Hz		0,7 s on / 0,3 s off	Industrial Alarm Germany	Tone 2	Tone 29
	Tone 12	intermittent	2400 Hz		0,5 s on / 0,5 s off		Tone 3	Tone 01
	Tone 13	intermittent	2850 Hz		0,5 s on/0,5 s off x 3 then 1 s off	ISO 8201 high tone, US Temporal	Tone 3	Tone 17
	Tone 14	alternating	440 - 554 Hz		0,4 s (440Hz) / 0,1 s (554Hz)	AFNOR France, NFS 32-001	Tone 16	Tone 01
	Tone 15	alternating	554 - 440 Hz		1 Hz	Swedish alarm	Tone 1	Tone 16
	Tone 16	alternating	800 - 1000 Hz		2 Hz		Tone 2	Tone 09
	Tone 17	alternating	2400 - 2900 Hz		2 Hz		Tone 3	Tone 1
	Tone 18	alternating	1000 - 2000 Hz		1 Hz	Singapore	Tone 2	Tone 3
	Tone 19	sweeping	500 - 1500 Hz		10 Hz		Tone 2	Tone 1
	Tone 20	sweeping	150 - 1000 Hz		rising 10 s, 40 s on, falling 10 s	Industrial Alarm Germany	Tone 25	Tone 29
	Tone 21	continuous	400 Hz		simulated horn		Tone 16	Tone 2
	Tone 22	sweeping	500 - 1200 Hz		rising in 3,75 s / 0,25 s off	Australian evacuation AS 2220	Tone 2	Tone 9
	Tone 23	sweeping	500 - 1200 Hz		rising in 3,5 s / 0,5 s off	Netherlands NEN 2575:2000	Tone 2	Tone 9
	Tone 24	sweeping	500 - 1200 Hz		0,5 s on/0,5 s off x 3 / 1,5 s off	Australia AS1670 evacuation	Tone 2	Tone 9
	Tone 25	sweeping	1200 - 500 Hz		1 Hz	evacuation Germany, DIN 33404-3	Tone 2	Tone 32
	Tone 26	sweeping	500 - 1200 Hz		0,3 Hz		Tone 1	Tone 32
	Tone 27	sweeping	1400 - 1600 Hz		rising in 1 s / falling in 0,5 s	NFC 48-265	Tone 2	Tone 9
	Tone 28	sweeping	2400 - 2900 Hz		1 Hz		Tone 17	Tone 3
	Tone 29	bell					Tone 16	Tone 2
	Tone 30	slow rise	500 - 2400 Hz		siren rising in 3 s, then cont. 2400 Hz		Tone 16	Tone 1
	Tone 31	slow rise	300 - 1200 Hz		siren rising in 3 s, then cont. 1200 Hz		Tone 16	Tone 1
	Tone 32	3-tone	660-550-440 Hz		repeating 3-tone gong, 7s		Tone 29	Tone 1

