

Diese Zeichnung ist unser geistiges Eigentum und darf ohne unsere Einwilligung weder kopiert, vervielfältigt noch Dritten oder Konkurrenzfirmen zugänglich gemacht werden. ( Art. 12 B.G. )  
 This drawing is copyright. Information contained thereon is supplied in confidence and must not be used for any other purpose than which it was supplied, or be reproduced without written permission of the owners.

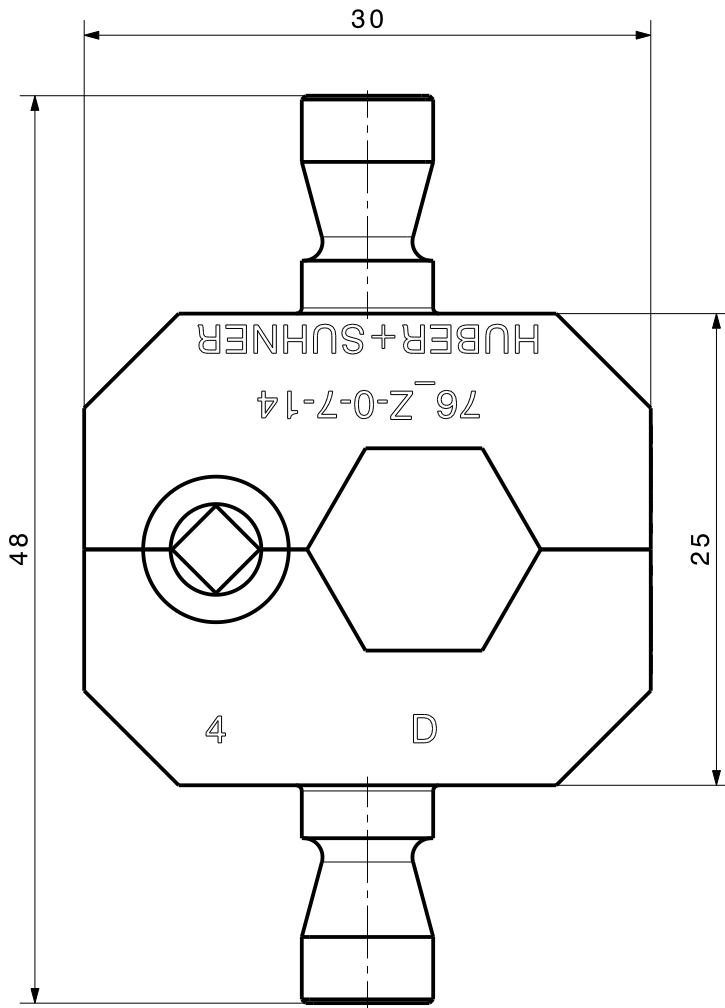

**Crimp insert for large crimp tool and table press**  
 Square cavity size 4 for centre contact  
 Hexagonal cavity size D for outer contact

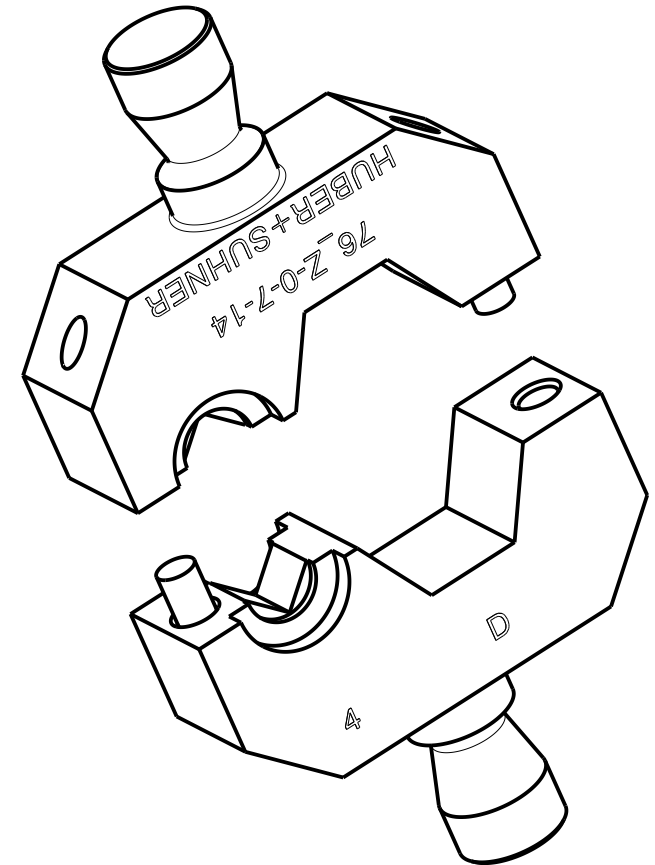

Cavity size	4	D
Dimension width across flats	3.28	10.70

type / Typ: 76_Z-0-7-14		
dimensions in millimeter [mm]	part no. / Teile Nr.: PRO-00377797	A sheet/Blatt XX / XX
description / Beschreibung		drawing-no. / Zeichnungsnr.
Crimp insert		DOU-00377797
alternative ID:		Release A