

4-Channel Digital Input and Output Module PROFI-safe V1.3

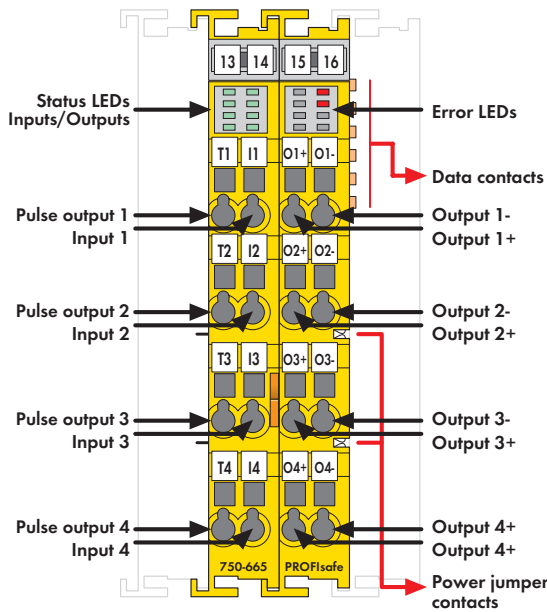

Delivered without miniature WSB markers

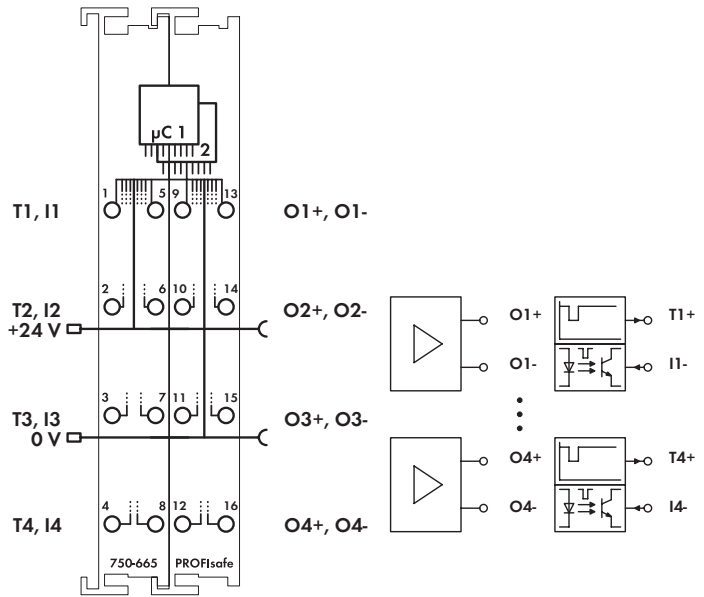

The 750-665/000-001 PROFI-safe Input and Output Module has 4 power outputs (O1 ... O4) and 4 pulse inputs (I1 ... I4) that are supplied by 4 different pulse outputs (T1 ... T4). The pulse outputs are short circuit proof. The inputs are constantly monitored for short circuits and supply voltage from separate sources. A green LED for each of the 4 input and the 4 output channels indicates the signal state, 2 red LEDs indicate internal or external errors. The address switch at the side of the module is used to set the PROFI-safe address. The fieldside and internal system are electrically isolated. Any configuration of the modules is possible when designing the fieldbus node. Grouping of module types is not necessary. Reference the product manual for further information.

When implementing new installations, please consider PROFI-safe V2 iPar 750-667/000-003 4/4-Channel Digital Input and Output Safety Module (see page 300).

Description	Item No.	Pack. Unit
4FDO 0.5A, 4FDI 24V DC PROFI-safe V1.3	750-665/000-001	1
Accessories		
Miniature WSB Quick marking system		
plain	248-501	5
with marking	see pages 352 ... 353	
Standards and Approvals		
Also see "Approvals Overview" in Section 1		
Basic standard safety applications	IEC 61508, parts 1-7, 1998 und 2000; EN 954-1 Cat. 4	
Conformity marking	CE	
UL 508	Class I, Div. 2, Grp. ABCD, T4	
ANSI/ISA 12.12.01	I M2 / II 3 GD Ex nA nL IIC T4	
EN 60079-0, -15		
EN 61241-0, -1		

Technical Data	
Inputs	I1 ... I4; pulse inputs (T1 ... T4)
Achievable safety classes	4 x Cat. 2/SIL 2 or 2 x Cat. 4/SIL 3
Outputs	O1 ... O4: outputs for actuators
Achievable safety classes	4 x Cat. 2/SIL 2 or 2 x Cat. 4/SIL 3
Voltage via power jumper contacts	24 V DC (-1.5 % ... +20 %)
Current via power jumper contacts (max.)	10 A DC
Current consumption typ. (KBUS)	55 mA
Reactance (max.)	capacitive reactance 2 nF; category DC 13
Response times (min ... max) Inputs	t _{on} (H->L) = 13 ms ... 71 ms t _{off} (H->L) = 13 ms ... 26 ms plus 2 x runtime internal bus plus 2 x runtime coupler - PLC plus runtime PLC
Response times (max.) Outputs	t _{on} (H->L) = 13 ms t _{off} (H->L) = 13 ms plus 2 x runtime internal bus plus 2 x runtime coupler - PLC plus runtime PLC
Switching frequency max.	5 Hz
resistive load	0.1 Hz, 5 Hz with free-wheeling diodes
inductive load acc. to IEC947-5-1,	
Proof test interval	10 years
Wire connection	CAGE CLAMP®
Cross sections	0.08 mm² ... 2.5 mm² / AWG 28 ... 14
Stripped lengths	8 ... 9 mm / 0.33 in
Width	24 mm
Weight	98 g
EMC CE-Immunity to interference	acc. to EN 61000-6-2 (2005)
EMC CE-Emission of interference	acc. to EN 61000-6-4 (2007)