

# MP-Bus Master Module

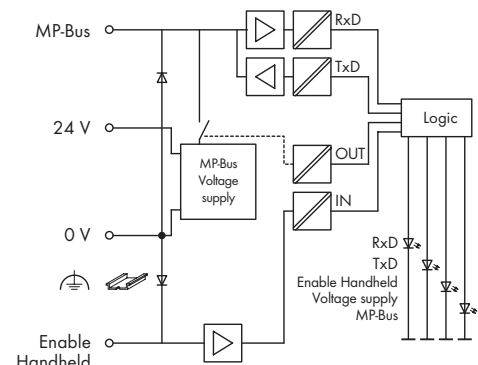
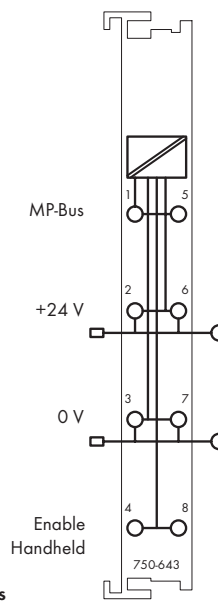
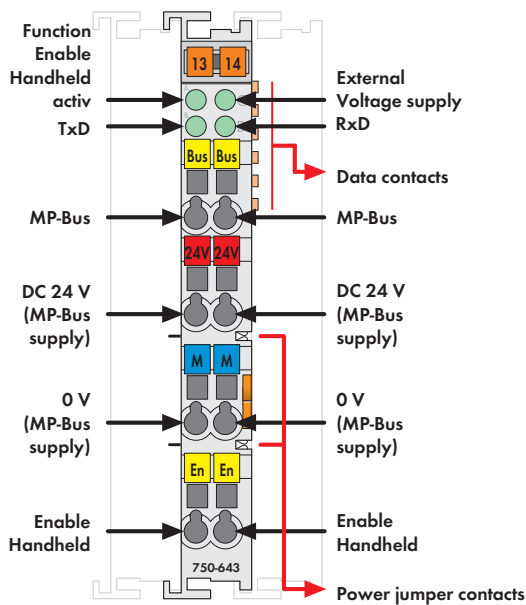

Delivered without miniature WSB markers

The 750-643 I/O module acts as a master for the MP bus (Multi Point Bus from Belimo/Switzerland) and allows the bus to be integrated into a higher level bus network such as Ethernet or LONWORKS®. The MP-bus controls HVAC actuators for dampers, regulator valves or VAV air volume controls. An additional product series for MP bus connection is the window ventilation system (FLS) from Belimo (MP bus connection for Belimo actuators, see Belimo documentation).

Devices that are equipped with an MP Bus connection, e.g. the Belimo MFT actuator series, can communicate with a higher level control via bus cable. The actuators have connections for active and passive sensors (temperature, humidity, ON/OFF switch, etc.), and are accessible via MP-Bus. An MP bus master, i.e., the WAGO I/O module, can manage up to 8 slaves (actuators) + 8 sensors (1 sensor can be connected to each slave) via a common bus line, which considerably reduces the wiring effort involved (for the actuators and sensors)(cable lengths for MP bus lines, see Belimo documentation\*).

\* Documentation available in German and English.

A Belimo parameterization unit (hand-held control unit, or Belimo PC tool) can be connected to the module to configure the Belimo actuators. The enable handheld contact can be used for this. The module deactivates its MP bus communication when the external parameterization unit is connected to this contact (or simply to the +24V power supply).

Description	Item No.	Pack. Unit
MP Bus Master module	750-643	1
<b>Accessories</b>		
Miniature WSB Quick marking system		
 plain	248-501	5
with marking	see pages 352 ... 353	
<b>Approvals</b>		
Also see "Approvals Overview" in Section 1		
Conformity marking	CE	
UL 508		
ANSI/ISA 12.12.01	Class I Div2 ABCD T4	
EN 60079-0, -15	I M2 / II 3 GD Ex nA IIC T4	
EN 61241-0, -1		

Technical Data	
MP Bus specifications	PP/MP specifications V1.21 from Belimo (Valid since 1.10.2002)
No. of slaves	max. 8
Voltage supply (MP-Bus)	DC24 V
Current consumption (MP-Bus)	25 mA without motor current (for MP-Bus) if the motors are supplied via the MP-Bus module, all motor currents must be added
Current consumption (internal)	15 mA
Power supply	via system voltage DC/DC
Isolation	500 V eff MP-bus/system
Internal bit width	1 byte C/S, 7 byte data
Wire connection	CAGE CLAMP®
Cross sections	0.08 mm² ... 2.5 mm² / AWG 28 ... 14
Stripped lengths	8 ... 9 mm / 0.33 in
Width	12 mm
Weight	52.3 g
EMC: CE - immunity to interference	acc. to EN 61000-6-2 (2002)
EMC: CE - emission of interference	acc. to EN 61000-6-3 (2004)