

Technical Data Sheet

Top View LEDs

67-21/LK2C-S6565B4B7B2/2T

Features

- P-LCC-2 package.
- Fluorescence Type
- High Luminous Intensity
- High Efficiency
- Pb-free.
- ESD protection
- The product itself will remain within RoHS compliant version.



Descriptions

- Due to the package design, 67-21 has wide viewing angle, low power consumption and white LEDs are devices which are materialized by combing Blue LEDs and special phosphors. This feature makes the LED ideal for light guide application.

Applications

- General lighting
- Decorative and Entertainment Lighting.
- Indicators.
- Illuminations.
- Switch lights.

Device Selection Guide

Chip	Emitted Color	Resin Color
Material		
InGaN	Cool White	Water Clear

Technical Data Sheet

Top View LEDs

67-21/LK2C-S6565B4B7B2/2T

Package Dimensions

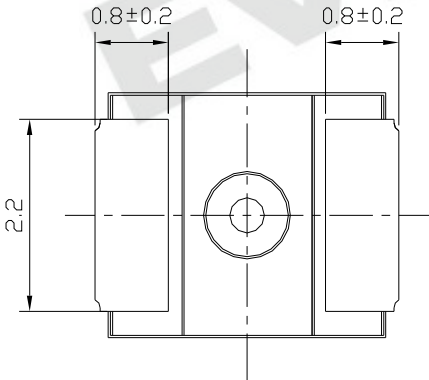
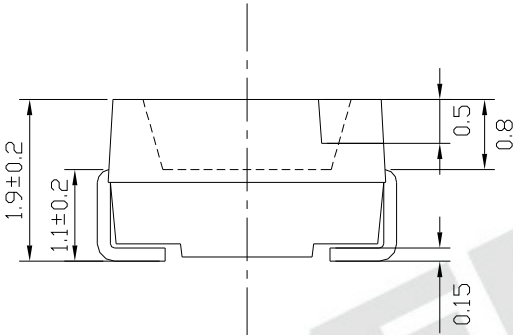
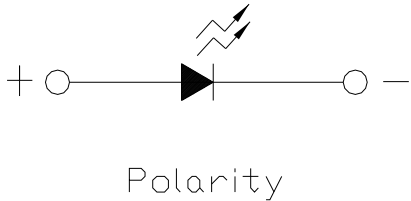
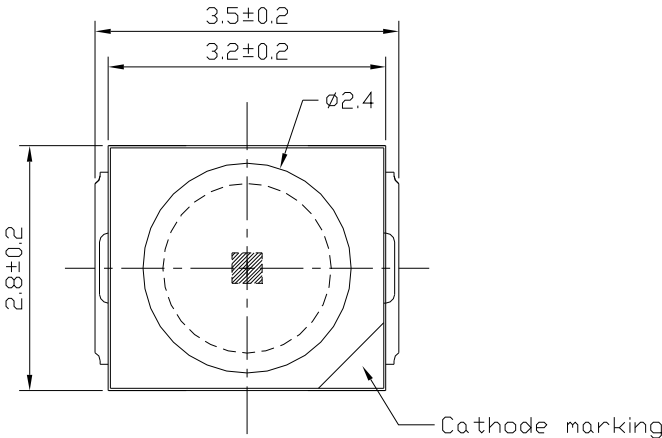

Recommended Solder Pad

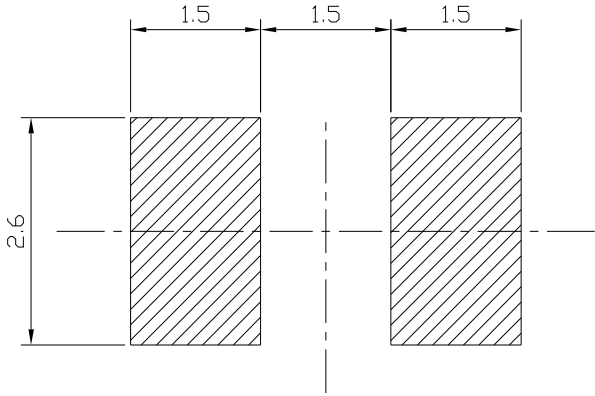

Note: Tolerance unless mentioned is ± 0.1 mm; Unit = mm

Technical Data Sheet

Top View LEDs

67-21/LK2C-S6565B4B7B2/2T

Absolute Maximum Ratings (Ta=25)

Parameter	Symbol	Rating	Unit
Reverse Voltage	V _R	5	V
Forward Current	I _F	30	mA
Peak Forward Current (Duty 1/10 @1KHz)	I _{FP}	100	mA
Power Dissipation	P _d	110	mW
Electrostatic Discharge	ESD	1000	V
Operating Temperature	T _{opr}	-40 ~ +85	
Storage Temperature	T _{stg}	-40 ~ +90	
Soldering Temperature	T _{sol}	Reflow Soldering : 260 for 10 sec. Hand Soldering : 350 for 3 sec.	

Electro-Optical Characteristics (Ta=25)

Parameter	Symbol	Min.	Typ.	Max.	Units	Condition
Luminous Flux	Φ	7.0	-----	9.0	lm	I _F =20mA
Viewing Angle	2θ _{1/2}	--	120	--	deg	I _F =20mA
Forward Voltage	V _F	2.9	-----	3.6	V	I _F =20mA
Color Rendering Index	----	70	----	----	----	I _F =20mA
Reverse Current	I _R	--	--	50	μA	V _R =5V

Note:

1. Tolerance of Luminous Flux: ±11%
2. Tolerance of Forward Voltage: ±0.05V
3. Tolerance of Color Rendering Index : ± 2

Technical Data Sheet

Top View LEDs

67-21/LK2C-S6565B4B7B2/2T

Bin Range of Luminous Flux

Bin Code	Min.	Max.	Unit	Condition
B4	7.0	7.5	lm	I _F =20mA
B5	7.5	8.0		
B6	8.0	8.5		
B7	8.5	9.0		

Bin Range of Forward Voltage

Group	Bin Code	Min.	Max.	Unit	Condition
B2	36	2.9	3.0	V	I _F =20mA
	37	3.0	3.1		
	38	3.1	3.2		
	39	3.2	3.3		
	40	3.3	3.4		
	41	3.4	3.5		
	42	3.5	3.6		

Notes:

1. Tolerance of Luminous Flux: ±11%
2. Tolerance of Forward Voltage: ±0.05V

Technical Data Sheet

Top View LEDs

67-21/LK2C-S6565B4B7B2/2T

Bin Range of Chromaticity Coordinates

$I_F=20mA$

CCT Group	Bin Code	CIE_x	CIE_y	Bin Code	CIE_x	CIE_y
6500K	65K-1	0.3205	0.3481	65K-3	0.3131	0.3290
		0.3117	0.3393		0.3048	0.3209
		0.3131	0.3290		0.3068	0.3113
		0.3213	0.3371		0.3145	0.3187
	65K-2	0.3117	0.3393	65K-4	0.3213	0.3371
		0.3028	0.3304		0.3131	0.3290
		0.3048	0.3209		0.3145	0.3187
		0.3131	0.3290		0.3221	0.3261

Note: Tolerance of Chromaticity Coordinates: ± 0.01

The C.I.E. 1931 Chromaticity Diagram

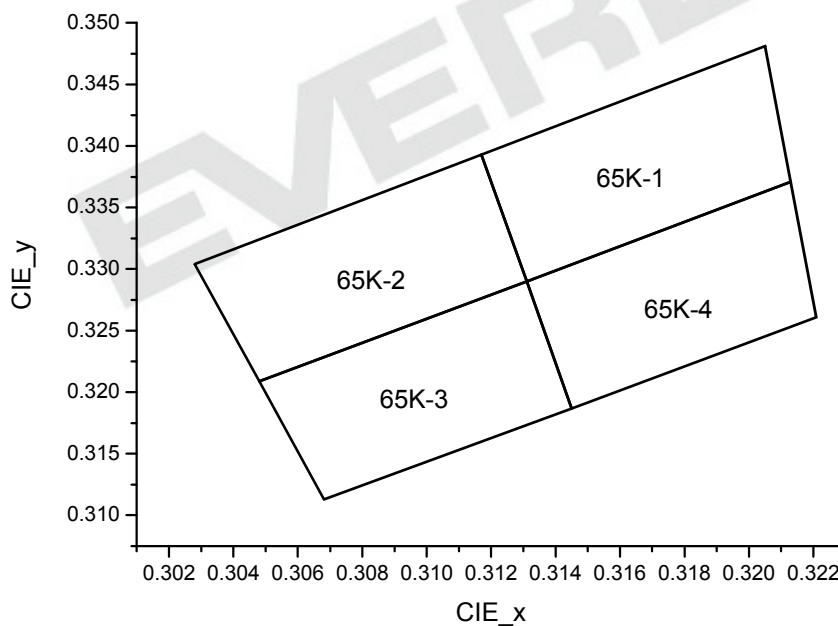

Technical Data Sheet

Top View LEDs

67-21/LK2C-S6565B4B7B2/2T

Typical Electro-Optical Characteristics Curves

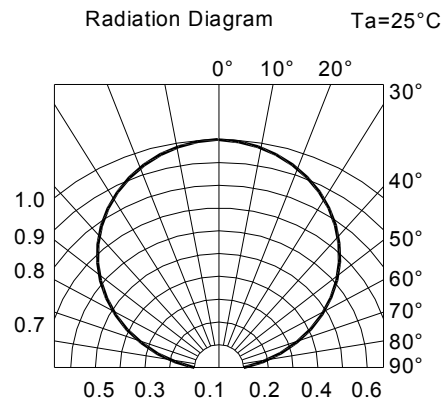
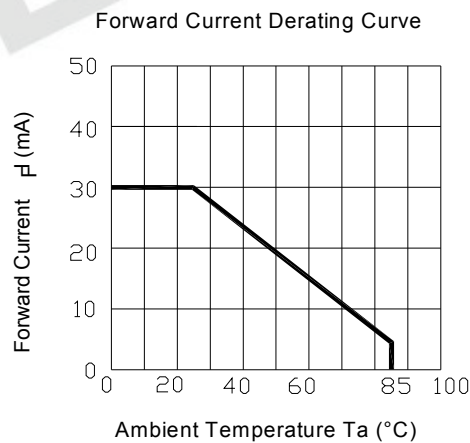
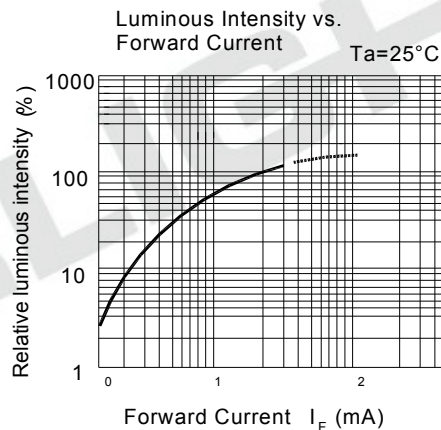
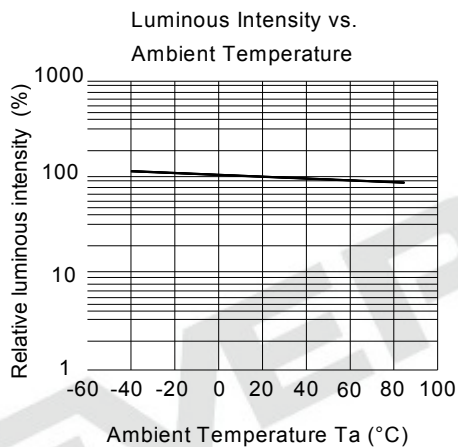
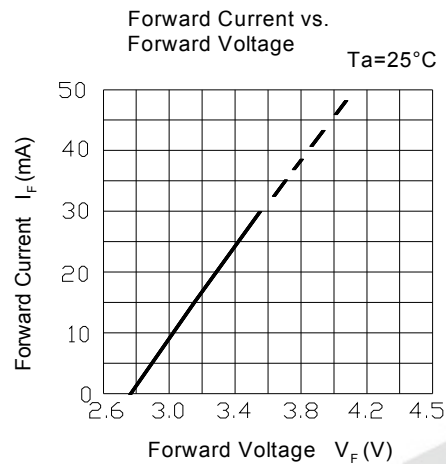
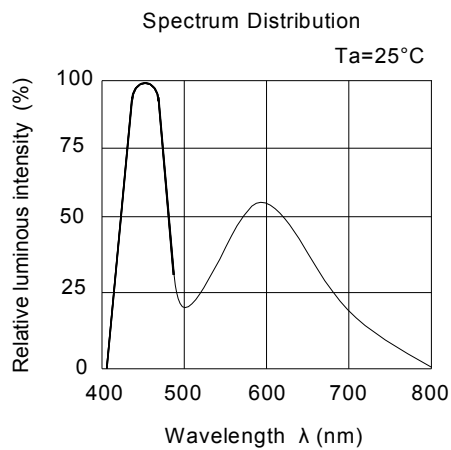

Technical Data Sheet

Top View LEDs

67-21/LK2C-S6565B4B7B2/2T

Label Explanation

CAT: Luminous Intensity Rank

HUE: Chromaticity Coordinates

REF: Forward Voltage Rank

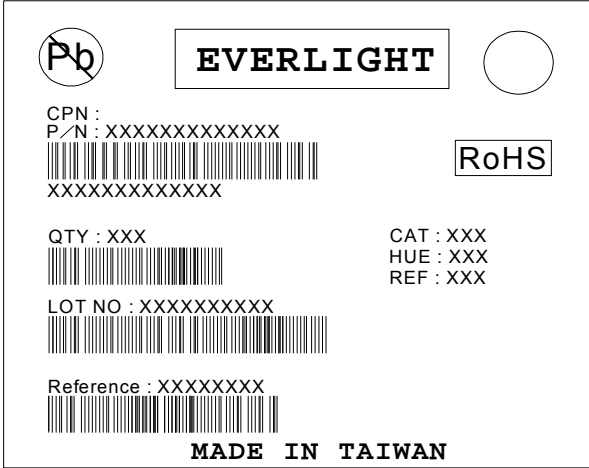

Reel Dimensions

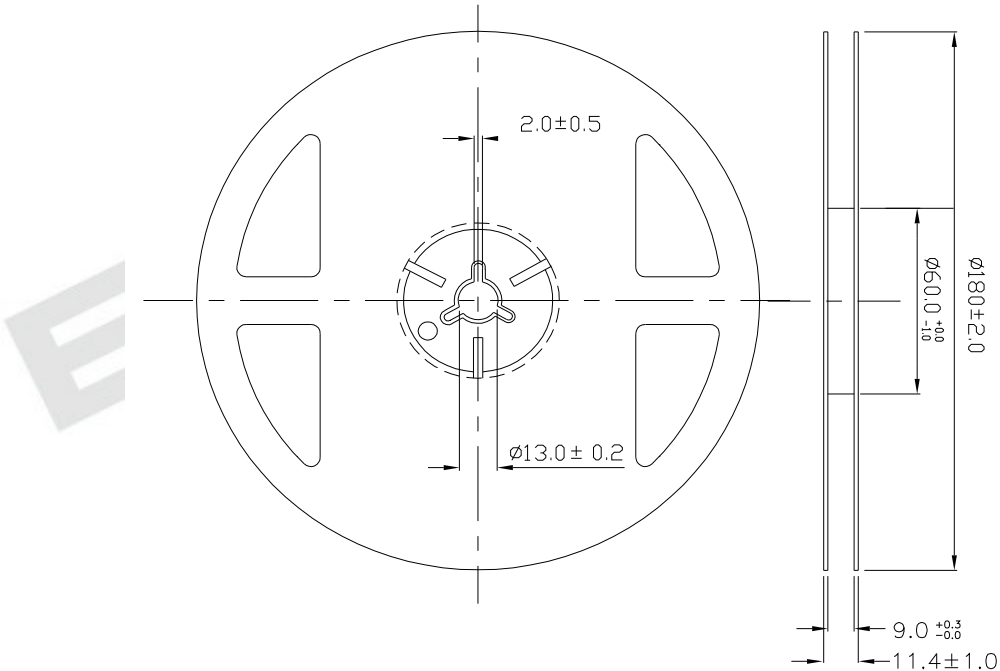

Note: Tolerance unless mentioned is ± 0.1 mm; Unit = mm

Technical Data Sheet

Top View LEDs

67-21/LK2C-S6565B4B7B2/2T

Carrier Tape Dimensions: Loaded Quantity 2000 pcs Per Reel.

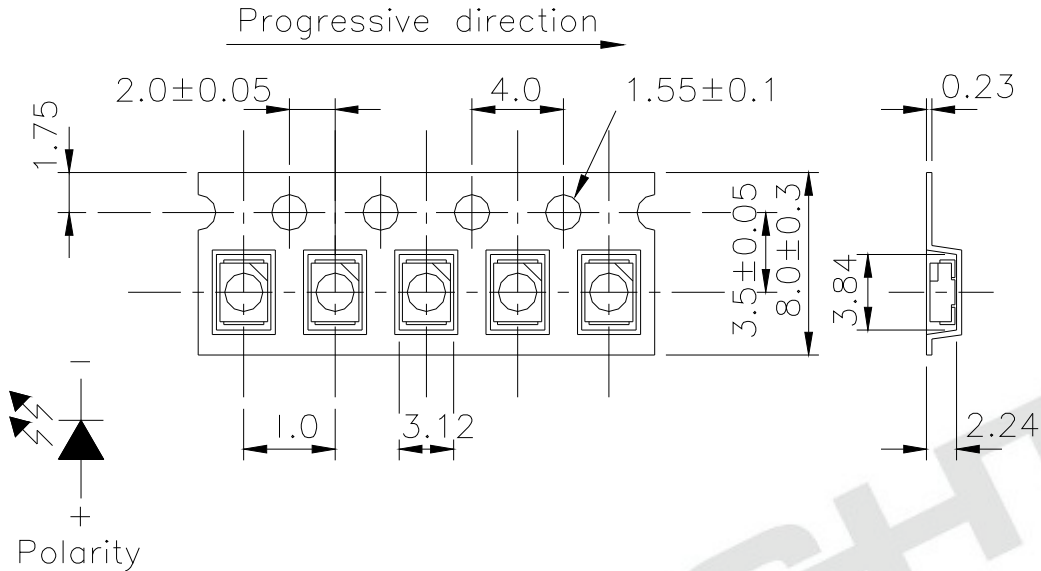

- Note:** 1. Tolerance unless mentioned is ± 0.1 mm; Unit = mm
 2. Minimum packing amount is 250/500/1000/2000 pcs per reel

Moisture Resistant Packaging

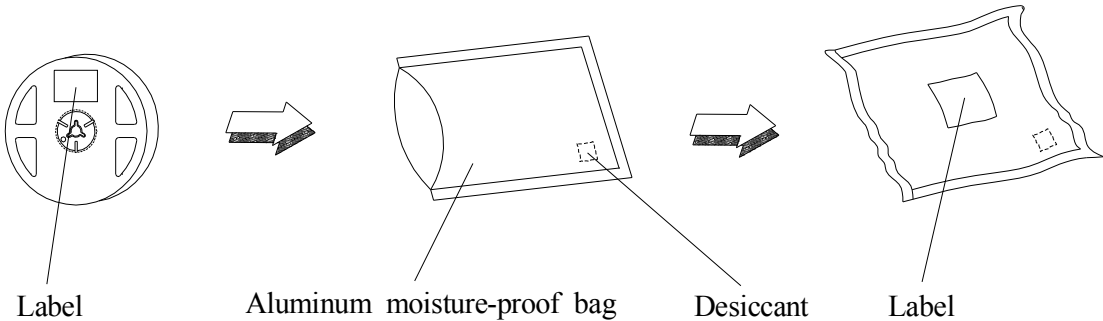

Technical Data Sheet

Top View LEDs

67-21/LK2C-S6565B4B7B2/2T

Reliability Test Items and Conditions

The reliability of products shall be satisfied with items listed below.

Confidence level : 90%

LTPD : 10%

No.	Items	Test Condition	Test Hours/Cycles	Sample Size	Ac/Re
1	Reflow Soldering	Temp. : 260 ±5 Max. 10 sec.	6 Min.	22 PCS.	0/1
2	Temperature Cycle	H : +100 15min 5 min L : -40 15min	300 Cycles	22 PCS.	0/1
3	Thermal Shock	H : +100 5min 10 sec L : -10 5min	300 Cycles	22 PCS.	0/1
4	High Temperature Storage	Temp. : 100	1000 Hrs.	22 PCS.	0/1
5	Low Temperature Storage	Temp. : -40	1000 Hrs.	22 PCS.	0/1
6	DC Operating Life	I _F = 20 mA	1000 Hrs.	22 PCS.	0/1
7	High Temperature / High Humidity	85 / 85%RH	1000 Hrs.	22 PCS.	0/1

Technical Data Sheet

Top View LEDs

67-21/LK2C-S6565B4B7B2/2T

Precautions for Use

1. Over-current-proof

Customer must apply resistors for protection; otherwise slight voltage shift will cause big current change (Burn out will happen).

2. Storage

2.1 Do not open moisture proof bag before the products are ready to use.

2.2 Before opening the package: The LEDs should be kept at 30 °C or less and 90%RH or less.

2.3 After opening the package: The LED's floor life are 168 hours under 30 °C or less and 60% RH or less. If unused LEDs remain, it should be stored in moisture proof packages.

2.4 If the moisture absorbent material (silica gel) has faded away or the LEDs have exceeded the storage time, baking treatment should be performed using the following conditions.

Baking treatment: 60±5 °C for 24 hours.

3. Soldering Condition

3.1 Pb-free solder temperature profile

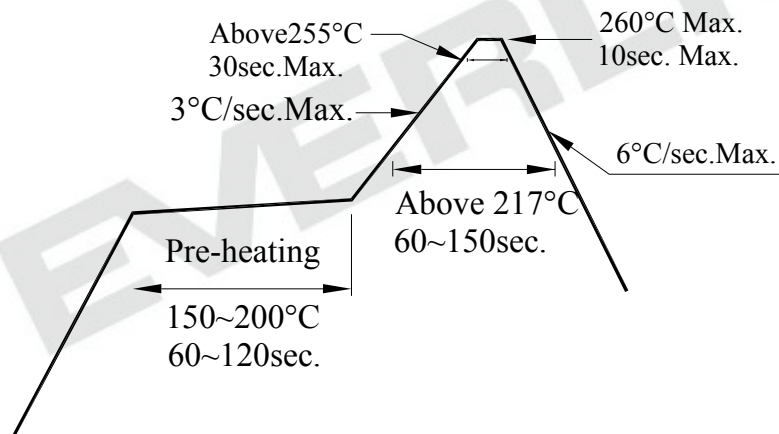

3.2 Reflow soldering should not be done more than two times.

3.3 When soldering, do not put stress on the LEDs during heating.

3.4 After soldering, do not warp the circuit board.

Technical Data Sheet

Top View LEDs

67-21/LK2C-S6565B4B7B2/2T

4. Soldering Iron

Each terminal is to go to the tip of soldering iron temperature less than 350 for 3 seconds within once in less than the soldering iron capacity 25W. Leave two seconds and more intervals, and do soldering of each terminal. Be careful because the damage of the product is often started at the time of the hand solder.

5. Repairing

Repair should not be done after the LEDs have been soldered. When repairing is unavoidable, a double-head soldering iron should be used (as below figure). It should be confirmed beforehand whether the characteristics of the LEDs will or will not be damaged by repairing.

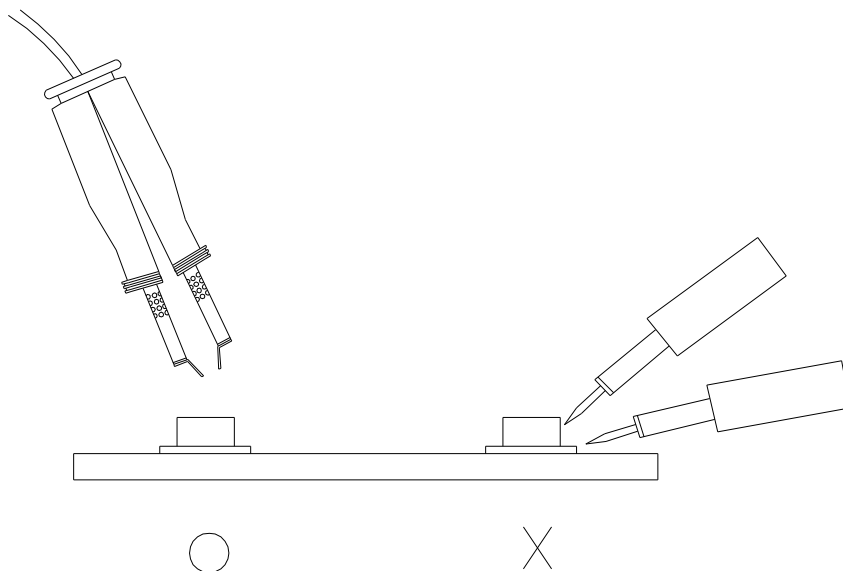

EVERLIGHT ELECTRONICS CO., LTD.
Office: No 25, Lane 76, Sec 3, Chung Yang Rd,
Tucheng, Taipei 236, Taiwan, R.O.C

Tel: 886-2-2267-2000, 2267-9936
Fax: 886-2267-6244, 2267-6189, 2267-6306
<http://www.everlight.com>