

**Technical Data Sheet**

**Mini Top View LED**

**65-21/GHC-YS2U1G/2T**

**Features**

- White SMT package.
- Optical indicator.
- Wide viewing angle.
- Soldering methods: reflow soldering
- Available on tape and reel
- Pb-free
- The product itself will remain within RoHS compliant version.



**Descriptions**

- The 65-21 series is available in soft orange, green, blue, and yellow. Due to the package design, the LED has wide viewing angle and optimized light coupling by inter reflector. This feature makes the ideal for light pipe application.

**Applications**

- Optical indicators.
- Coupling into light guides.
- Backlighting (LCD, cellular phones, switches, keys, displays, illuminated advertising, general lighting).
- Coupling into light guides; Interior automotive lighting (e.g. dashboard backlighting, etc.).

**Device Selection Guide**

Chip	Emitted Color	Resin Color
Material		
InGaN	Brilliant Green	Water Clear

**Technical Data Sheet**

**Mini Top View LED**

**65-21/GHC-YS2U1G/2T**

**Package Outline Dimensions**

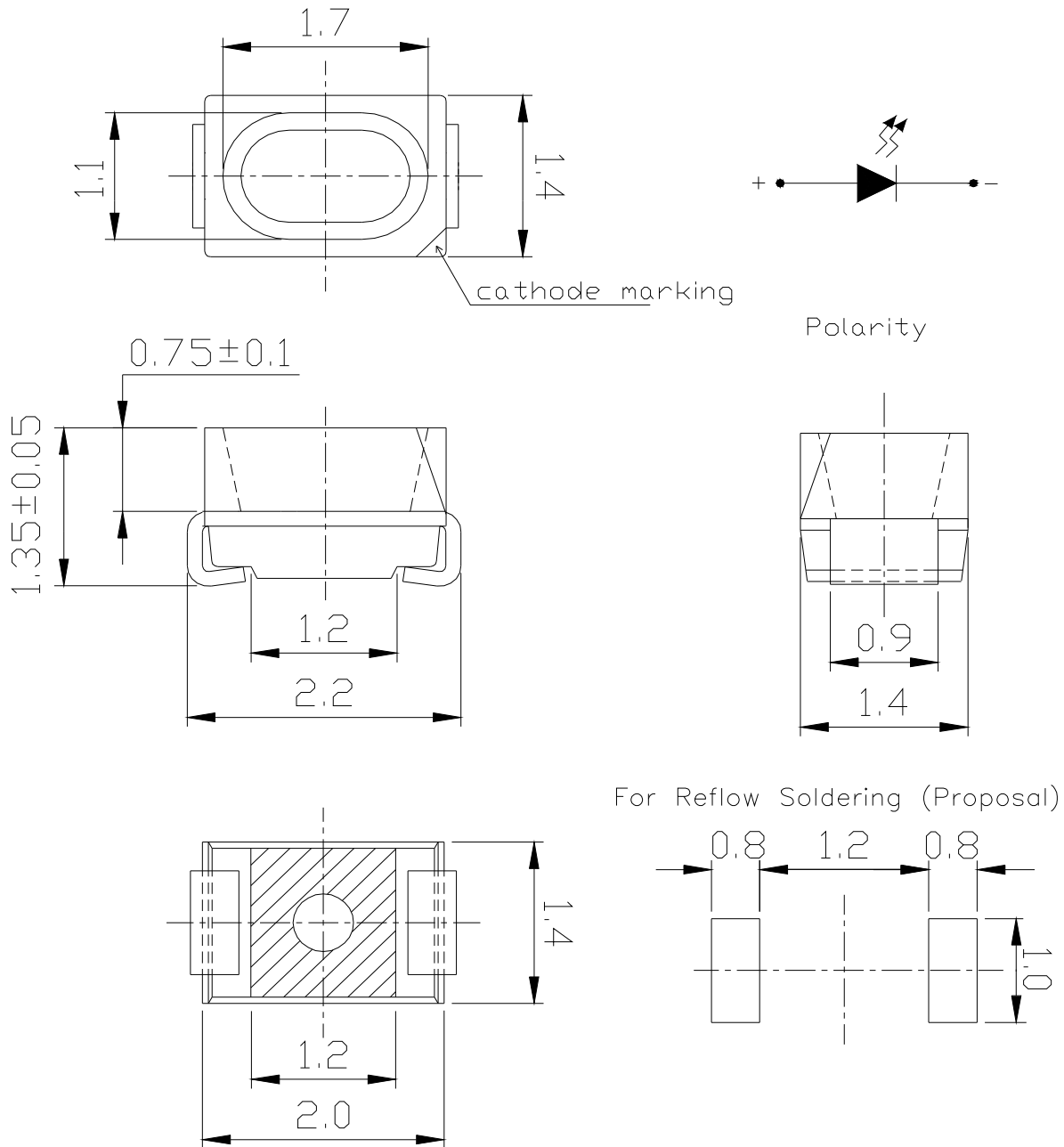

**Notes:** All dimensions are in millimeters; Tolerances unspecified are ±0.1mm.

Technical Data Sheet

Mini Top View LED

**65-21/GHC-YS2U1G/2T**

**Absolute Maximum Ratings (Ta=25 )**

Parameter	Symbol	Rating	Unit
Reverse Voltage	V <sub>R</sub>	5	V
Forward Current	I <sub>F</sub>	25	mA
Power Dissipation	P <sub>d</sub>	100	mW
Peak Forward Current (Duty 1/10 @1KHz)	I <sub>FP</sub>	95	mA
Electrostatic Discharge(HBM)	ESD	150	V
Operating Temperature	T <sub>opr</sub>	-40 ~ +85	
Storage Temperature	T <sub>stg</sub>	-40~ +90	
Soldering Temperature	T <sub>sol</sub>	Reflow Soldering : 260 for 10 sec. Hand Soldering : 350 for 3 sec.	

**Electro-Optical Characteristics (Ta=25 )**

Parameter	Symbol	Min.	Typ.	Max.	Unit	Condition
Luminous Intensity	I <sub>v</sub>	225	-----	565	mcd	I <sub>F</sub> =20mA
Viewing Angle	2θ1/2	----	120	----	deg	
Peak Wavelength	λ <sub>p</sub>	----	518	----	nm	
Dominant Wavelength	λ <sub>d</sub>	520	----	535	nm	
Spectrum Radiation Bandwidth	Δλ	----	20	----	nm	
Forward Voltage	V <sub>F</sub>	2.70	----	3.70	V	
Reverse Current	I <sub>R</sub>	----	----	50	μA	V <sub>R</sub> =5V

**Notes:**

- 1.Tolerance of Luminous Intensity : ±11%
- 2.Tolerance of Dominant Wavelength : ±1nm
- 3.Tolerance of Forward Voltage : ±0.05V

**Technical Data Sheet**

**Mini Top View LED**

**65-21/GHC-YS2U1G/2T**

**Bin Range of Luminous intensity:**

Bin	Min	Max	Unit	Condition
S2	225	285	mcd	I <sub>F</sub> =20mA
T1	285	360		
T2	360	450		
U1	450	565		

**Bin Range of Dominate Wavelength:**

Group	Bin	Min	Max	Unit	Condition
Y	X	520	525	nm	I <sub>F</sub> =20mA
	Y	525	530		
	Z	530	535		

**Bin Rang of Forward Voltage**

Group	Bin	Min	Max	Unit	Condition
G	34	2.70	2.80	V	I <sub>F</sub> =20mA
	35	2.80	2.90		
	36	2.90	3.00		
	37	3.00	3.10		
	38	3.10	3.20		
	39	3.20	3.30		
	40	3.30	3.40		
	41	3.40	3.50		
	42	3.50	3.60		
	43	3.60	3.70		

**Notes:**

- 1.Tolerance of Luminous Intensity  $\pm 11\%$
- 2.Tolerance of Dominant Wavelength  $\pm 1\text{nm}$
- 3.Tolerance of Forward Voltage  $\pm 0.05\text{V}$

Technical Data Sheet

Mini Top View LED

**65-21/GHC-YS2U1G/2T**

Typical Electro-Optical Characteristics Curves

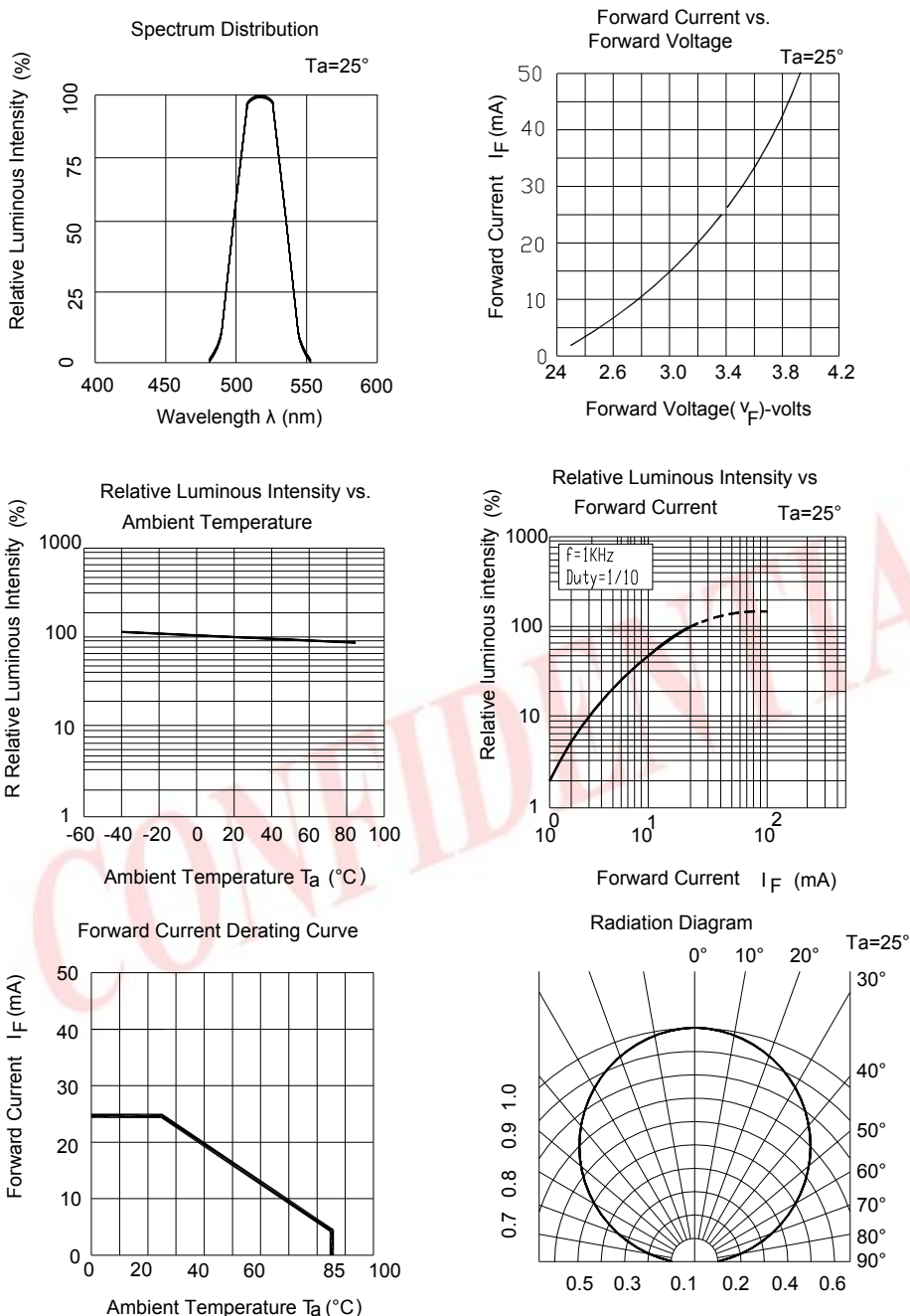

**Technical Data Sheet**

**Mini Top View LED**

**65-21/GHC-YS2U1G/2T**

**Label Explanation**

CAT: Luminous Intensity Rank

HUE: Dom. Wavelength Rank

REF: Forward Voltage Rank



**Reel Dimensions**

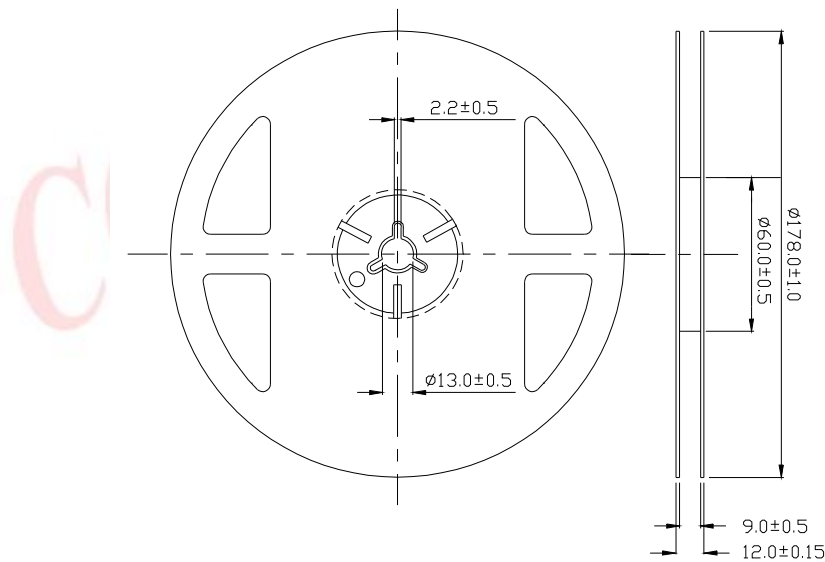

**Note:** The tolerances unless mentioned is  $\pm 0.1\text{mm}$  ; Unit = mm

**Technical Data Sheet**

**Mini Top View LED**

**65-21/GHC-YS2U1G/2T**

**Carrier Tape Dimensions: Loaded Quantity 2000 pcs Per Reel.**

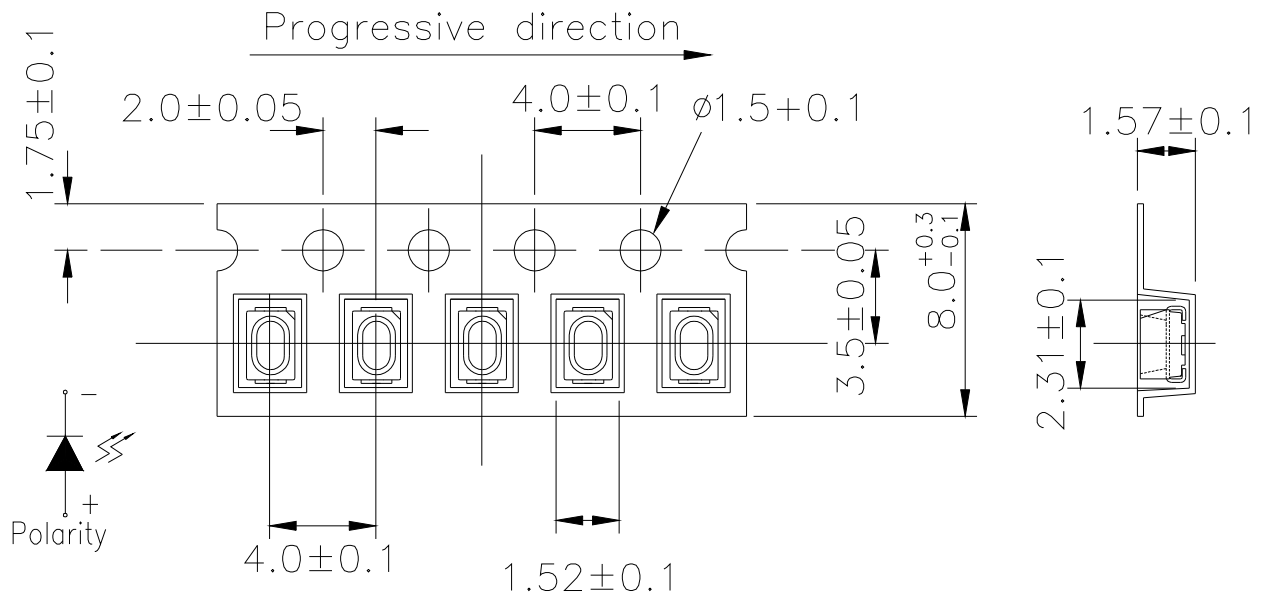

**Note:** The tolerances unless mentioned is  $\pm 0.1\text{mm}$  ; Unit = mm

**Moisture Resistant Packaging**

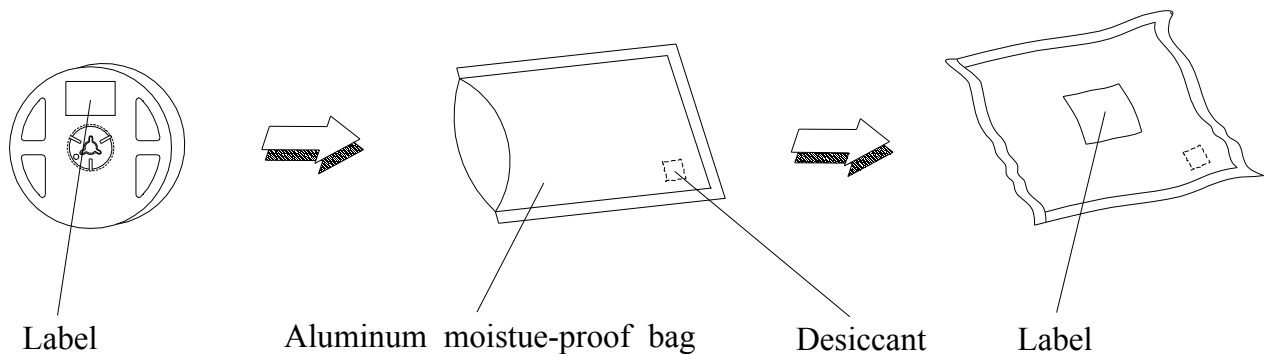

**Technical Data Sheet**

**Mini Top View LED**

**65-21/GHC-YS2U1G/2T**

**Reliability Test Items and Conditions**

The reliability of products shall be satisfied with items listed below.

Confidence level : 90%

LTPD : 10%

No.	Items	Test Condition	Test Hours/Cycles	Sample Size	Ac/Re
1	Reflow Soldering	Temp. : 260 ±5 Min. 5sec.	6 Min.	22 PCS.	0/1
2	Temperature Cycle	H : +100 15min 5 min L : -40 15min	300 Cycles	22 PCS.	0/1
3	Thermal Shock	H : +100 5min 10 sec L : -10 5min	300 Cycles	22 PCS.	0/1
4	High Temperature Storage	Temp. : 100	1000 Hrs.	22 PCS.	0/1
5	Low Temperature Storage	Temp. : -40	1000 Hrs.	22 PCS.	0/1
6	DC Operating Life	I <sub>F</sub> = 20 mA	1000 Hrs.	22 PCS.	0/1
7	High Temperature / High Humidity	85 / 85%RH	1000 Hrs.	22 PCS.	0/1



## Technical Data Sheet

### Mini Top View LED

**65-21/GHC-YS2U1G/2T**

#### Precautions for Use

##### 1. Over-current-proof

Customer must apply resistors for protection; otherwise slight voltage shift will cause big current change (Burn out will happen).

##### 2. Storage

2.1 Do not open moisture proof bag before the products are ready to use.

2.2 Before opening the package: The LEDs should be kept at 30 °C or less and 90%RH or less.

2.3 After opening the package: The LED's floor life is 1 year under 30 °C or less and 60% RH or less. If unused LEDs remain, it should be stored in moisture proof packages.

2.4 If the moisture absorbent material (silica gel) has faded away or the LEDs have exceeded the storage time, baking treatment should be performed using the following conditions.

Baking treatment: 60±5 °C for 24 hours.

##### 3. Soldering Condition

##### 3.1 Pb-free solder temperature profile

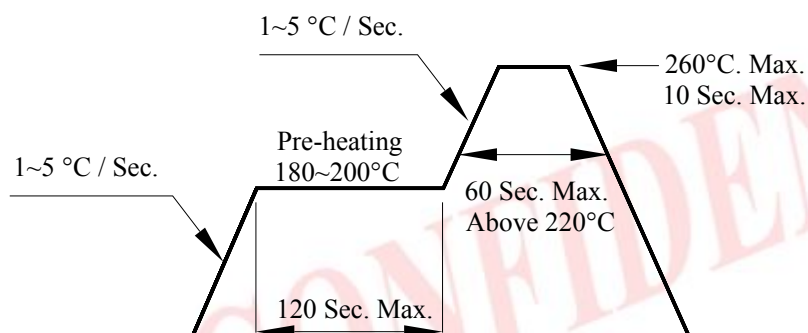

3.2 Reflow soldering should not be done more than two times.

3.3 When soldering, do not put stress on the LEDs during heating.

3.4 After soldering, do not warp the circuit board.

## Technical Data Sheet

### Mini Top View LED

**65-21/GHC-YS2U1G/2T**

#### 4. Soldering Iron

Each terminal is to go to the tip of soldering iron temperature less than 280 for 3 seconds within once in less than the soldering iron capacity 25W. Leave two seconds and more intervals, and do soldering of each terminal. Be careful because the damage of the product is often started at the time of the hand solder.

#### 5. Repairing

Repair should not be done after the LEDs have been soldered. When repairing is unavoidable, a double-head soldering iron should be used (as below figure). It should be confirmed beforehand whether the characteristics of the LEDs will or will not be damaged by repairing.

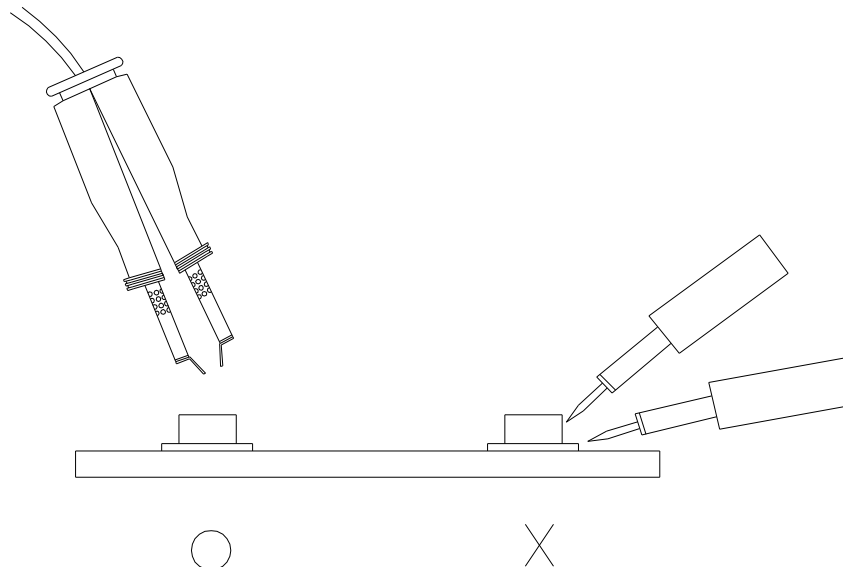

**EVERLIGHT ELECTRONICS CO., LTD.**  
Office: No 25, Lane 76, Sec 3, Chung Yang Rd,  
Tucheng, Taipei 236, Taiwan, R.O.C

Tel: 886-2-2267-2000, 2267-9936  
Fax: 886-2267-6244, 2267-6189, 2267-6306  
<http://www.everlight.com>