

PART NO	REV	SYMBOL	DESCRIPTION	LOCATED	REASON	SIGN	DATE
48-862-06	A					Evan Kuo	2007/11/28

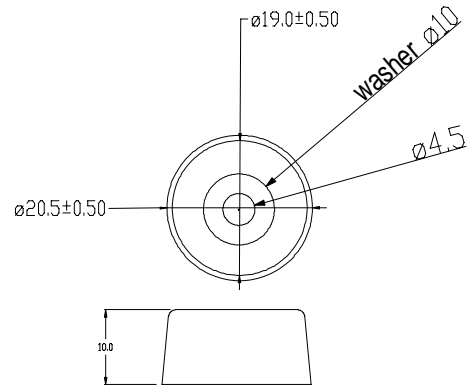

- NOTES :
- 1.MATERIAL: CR UL94V-0 + Washer(10*4.5*0.8)
 - 2.COLOR:BLACK
 - 3.TAPE ADHESION:
 - 4.HARDNESS: 70°±5°
 - 5.PART IS TO BE FREE OF OIL,DIRT AND SHAPE EDGE
 - 6.TOLERANCE CLASS: +/-0.50
 7. Ⓢ INDICATES CRITICAL DIMENSION

MODEL			NAME	Foot pad (20.5*18*10)				TOLERANCE UNLESS OTHERWISE SPECIFIED (±)								
DRN	Evan Kuo	2007/11/28	MATERIAL	SEE NOTE				CLASS	A	B	C	D	E	F	G	
DSN			FINISH	SEE NOTE				< 8mm	0.05	0.1	0.1	0.2	0.2	0.4	0.4	
CKD			SCALE		DIM IN	mm	8 ~ 25mm	0.08	0.15	0.15	0.3	0.3	0.6	0.6		
APPD			SHEET		CAVITIES		25 ~ 80mm	0.12	0.2	0.25	0.4	0.5	0.8	1.0		
SPEED GOLDEN									80 ~ 250mm	0.25	0.3	0.4	0.6	0.8	1.2	1.5
									> 800mm	1.0	1.0	1.5	1.7	3.0	4.0	6.0
SPEED GOLDEN									ANGLE	0.5	0.5	0.5	0.5	1.0	1.0	1.0
									FILE NAME	Foot pad (20.5*18*10)						
							PART NO.		48-862-06							