

42219-1 ✓ ACTIVE

FASTON | FASTON 250

TE Internal #: 42219-1

FASTON 250, Quick Disconnects, Receptacle, 18 – 14 AWG Wire Size, .82 – 2.08 mm² Wire Size, Mating Tab Width .25 in [6.35 mm], Straight, Steel

[View on TE.com >](#)



Terminals & Splices > Quick Disconnects

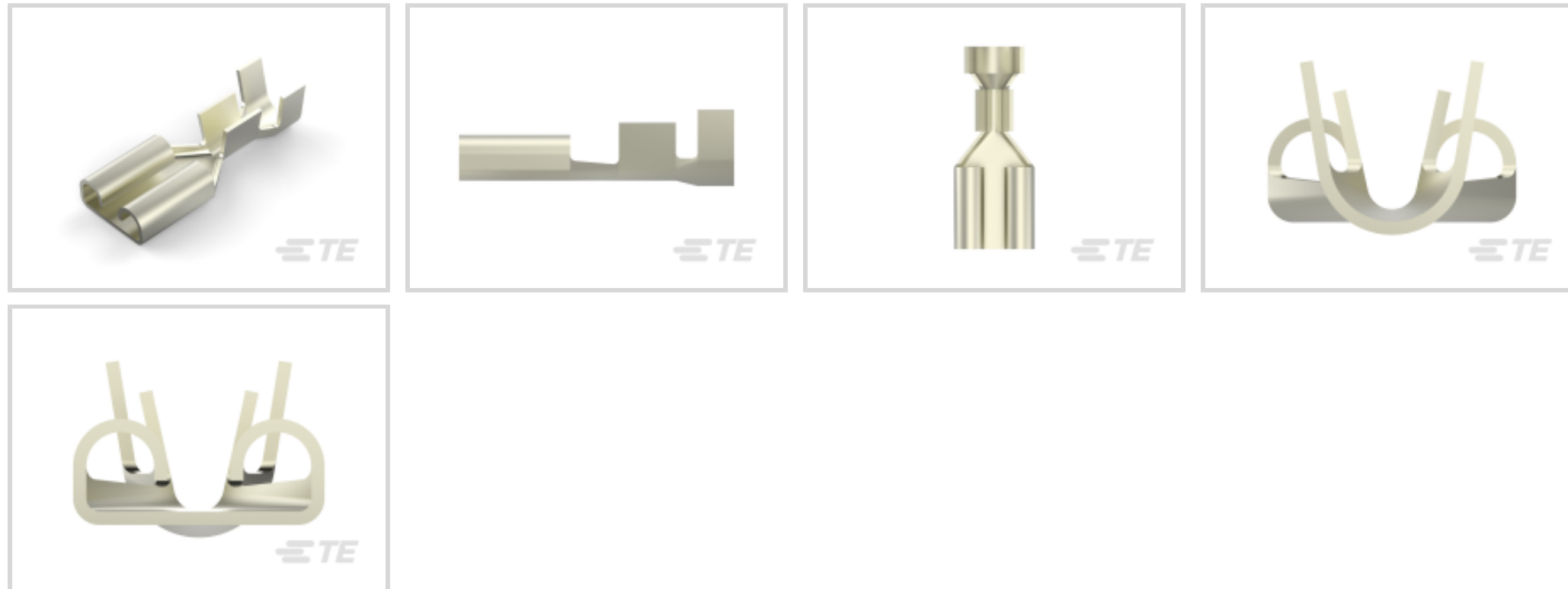

Quick Disconnect Terminal Type: **Receptacle**

Wire Size: **.82 – 2.08 mm²**

Mating Tab Width: **6.35 mm [.25 in]**

Mating Tab Thickness: **.81 mm [.032 in]**

Features

Product Type Features

Terminates To	Wire & Cable
Wire/Cable Type	Regular Wire
Wire Stop	No
Insertion Force	Normal
Sealable	No

Configuration Features

Connection Capacity	Single
---------------------	--------

Contact Features

Quick Disconnect Terminal Type	Receptacle
Mating Tab Width	6.35 mm[.25 in]
Mating Tab Thickness	.81 mm[.032 in]
Terminal Orientation	Straight
Contact Base Material	Steel
Terminal Plating Material	Nickel
Crimp Type	F-Crimp



Barrel Type	Open
-------------	------

Mechanical Attachment

Mating Retention Type	Dimple
-----------------------	--------

Wire Insulation Support	With
-------------------------	------

Dimensions

Accepts Wire Insulation Diameter Range	3.1 – 4.3 mm [.12 – .17 in]
--	-----------------------------

Receptacle Terminal Stock Thickness	.41 mm [.016 in]
-------------------------------------	------------------

Overall Length	19.12 mm [.753 in]
----------------	--------------------

Wire Size	.82 – 2.08 mm ²
-----------	----------------------------

Usage Conditions

Insulation Requirement	Uninsulated
------------------------	-------------

Operating Temperature Range	-40 – 250 °C [-40 – 482 °F]
-----------------------------	-----------------------------

Industry Standards

CSA Certified	Yes
---------------	-----

UL Rating	Recognized
-----------	------------

Packaging Features

Packaging Quantity	10000
--------------------	-------

Packaging Method	Strip/Reel
------------------	------------

Other

Line	Premier
------	---------

Product Compliance

[For compliance documentation, visit the product page on TE.com>](#)

EU RoHS Directive 2011/65/EU	Compliant
------------------------------	-----------

EU ELV Directive 2000/53/EC	Compliant
-----------------------------	-----------

China RoHS 2 Directive MIIT Order No 32, 2016	No Restricted Materials Above Threshold
---	---

EU REACH Regulation (EC) No. 1907/2006	Current ECHA Candidate List: JAN 2022 (223) Candidate List Declared Against: JAN 2022 (223) Does not contain REACH SVHC
--	---

Halogen Content	Low Halogen - Br, Cl, F, I < 900 ppm per homogenous material. Also BFR/CFR/PVC Free
-----------------	---

Solder Process Capability

Not applicable for solder process capability

Product Compliance Disclaimer

This information is provided based on reasonable inquiry of our suppliers and represents our current actual knowledge based on the information they provided. This information is subject to change. The part numbers that TE has identified as EU RoHS compliant have a maximum concentration of 0.1% by weight in homogenous materials for lead, hexavalent chromium, mercury, PBB, PBDE, DBP, BBP, DEHP, DIBP, and 0.01% for cadmium, or qualify for an exemption to these limits as defined in the Annexes of Directive 2011/65/EU (RoHS2). Finished electrical and electronic equipment products will be CE marked as required by Directive 2011/65/EU. Components may not be CE marked. Additionally, the part numbers that TE has identified as EU ELV compliant have a maximum concentration of 0.1% by weight in homogenous materials for lead, hexavalent chromium, and mercury, and 0.01% for cadmium, or qualify for an exemption to these limits as defined in the Annexes of Directive 2000/53/EC (ELV). Regarding the REACH Regulation, the information TE provides on SVHC in articles for this part number is based on the latest European Chemicals Agency (ECHA) 'Guidance on requirements for substances in articles' posted at this URL: <https://echa.europa.eu/guidance-documents/guidance-on-reach>

Compatible Parts



TE Part # 58524-1
PROCRIMPER TOOL & DIE



TE Part # 90165-1
DAHT 250 FASTON REC 18-14 ASSY



TE Part # 63892-1
250 FASTON REC 16-12 AWG NPST

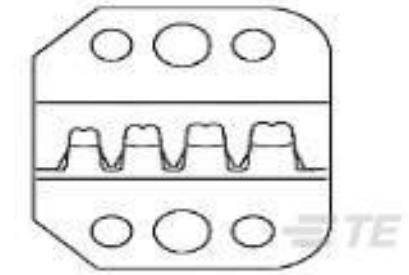

TE Part # 58524-2
PROCRIMPER DIE



TE Part # 2-2150016-2
OCEAN_2.0 Applicator-E-100F180F



TE Part # 60705-1
FASTON 250 REC 18-14 AWG NPST

Also in the Series | FASTON 250



Compression Connectors(4)

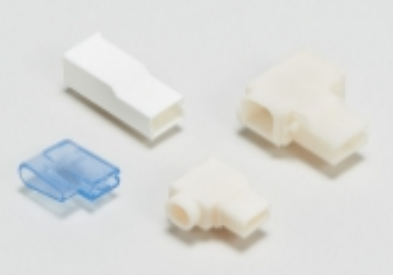

Crimp Terminal Housings(143)



Insertion & Extraction Tools(6)



Magnet Wire Terminals(1)



PCB Terminals(144)



Quick Disconnects(456)



Splices(4)

Customers Also Bought



TE Part #5-1971775-3
PTL 2X3 CAP PANEL MT HIGH TEMP
KEY A LGR



TE Part #917709-1
2.5 SIGNAL D/LOCK D.L.P 13P



TE Part #917697-1
STD Temp Signal Double Lock Plug



TE Part #2-34159-1
TERMINAL, PG R 16-14 6

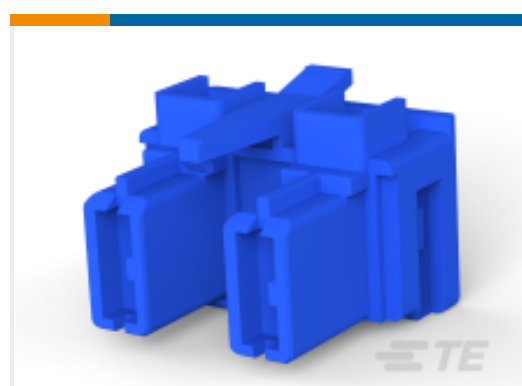

TE Part #1-1743165-8
PL EX 2P .250 (6.3 MM) FLAG BLUE



TE Part #1743221-1
250 PL EX FLAG REC. 18-12AWG PTBR



TE Part #60705-1
FASTON 250 REC 18-14 AWG NPST

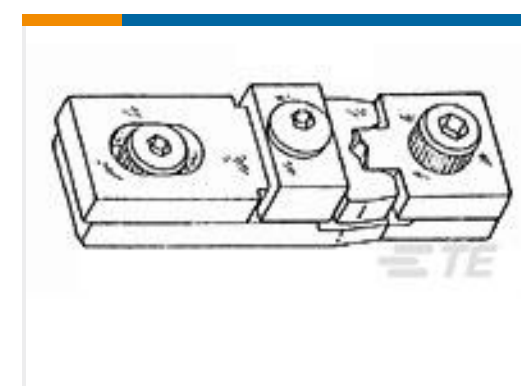

TE Part #59828-1
TETRA-CRIMP DIE 12-10



TE Part #4-455892-4
HOLD DOWN

Documents

Product Drawings

250 FASTON REC 18-14 AWG NPST

English

CAD Files

3D PDF

3D

Customer View Model

ENG_CVM_CVM_42219-1_BV.2d_dxf.zip



English

Customer View Model

[ENG_CVM_CVM_42219-1_BV.3d_igs.zip](#)

English

Customer View Model

[ENG_CVM_CVM_42219-1_BV.3d_stp.zip](#)

English

By downloading the CAD file I accept and agree to the [Terms and Conditions](#) of use.

Datasheets & Catalog Pages

[FASTIN_FASTON_Product_Line](#)

English

[82004 FASTON Terminals \(Insulated and Uninsulated\) Catalog - FASTON Receptacles Section](#)

English

Product Specifications

[Application Specification](#)

English

[Application Specification](#)

English

[Wire Preparation And Crimp Inspection Guide](#)

English

Product Environmental Compliance

[MD_42219-1_03202018029_dmtec](#)

English

[MD_42219-1_03202018029_dmtec](#)

English

Agency Approvals

[Agency Approval Document](#)

English