

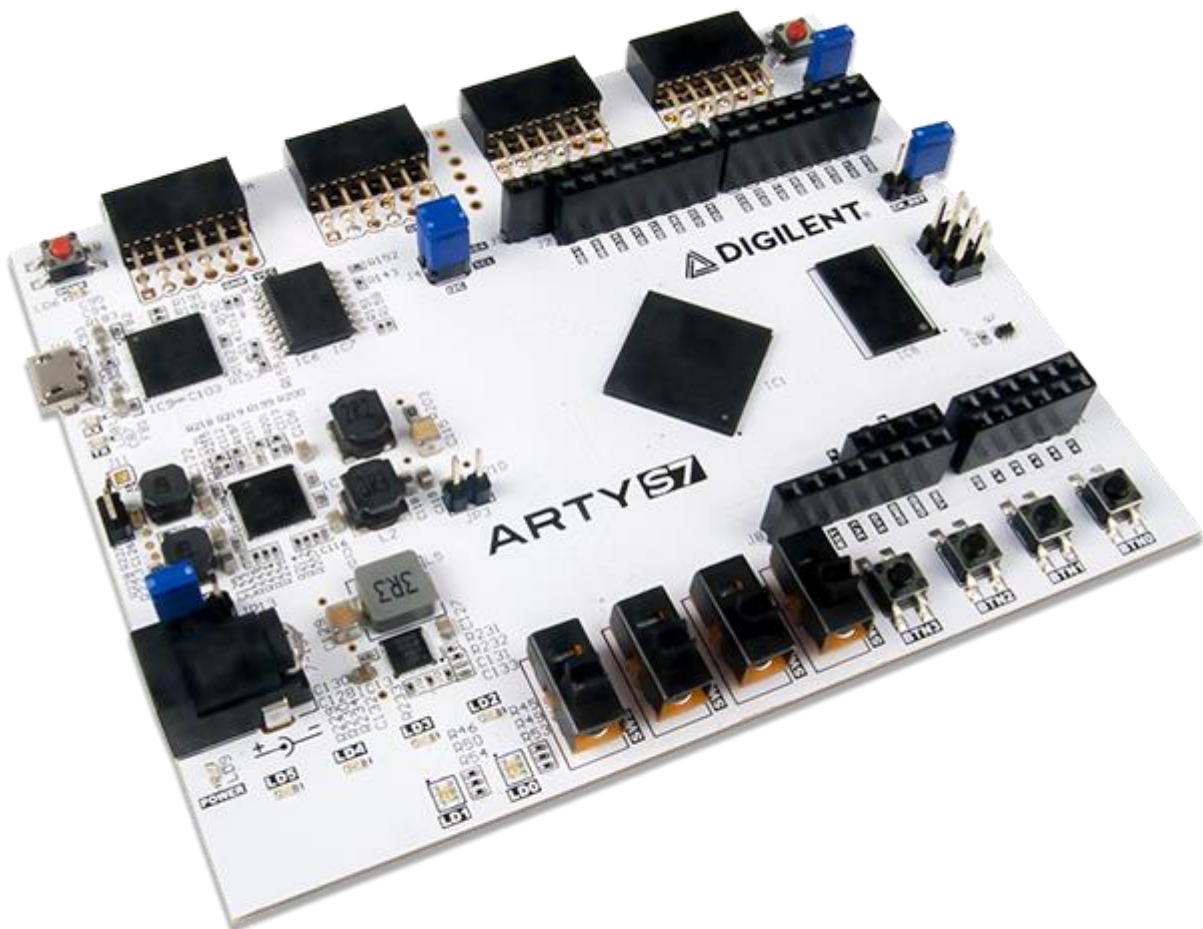

Arty S7 Reference Manual

The Arty S7 board features the new Xilinx Spartan-7 FPGA and is the latest member of the Arty FPGA development board family from Digilent. The Spartan-7 FPGA offers the most size, performance, and cost-conscious design engineered with the latest technologies from Xilinx and is fully compatible with Vivado Design Suite. Putting this FPGA in the Arty form factor provides users with a wide variety of I/O and expansion options. Use the dual row Arduino® connectors to mount one of the hundreds of hardware compatible shields available, or use the Pmod ports with Digilent's pre-made Pmod IP blocks for a more streamlined design experience. Arty S7 was designed to be MicroBlaze ready and comes out of the box ready to use with the free Xilinx WebPack version of Vivado Design Suite.



Features

- **Xilinx Spartan-7 50 FPGA (xc7s50csga324-1)**
 - 8,150 slices (each slice contains four 6-input LUTs and 8 flip-flops)
 - 2,700 Kbits of fast block RAM
 - Five clock management tiles, each with a phase-locked loop (PLL)
 - 120 DSP slices
 - Internal clock speeds exceeding 450MHz
 - On-chip analog-to-digital converter (XADC)
 - Programmable over JTAG and Quad-SPI Flash
- **Memory**
 - 256MB DDR3L with a 16-bit bus @ 650MHz
 - 16MB Quad-SPI Flash
- **Power**
 - Powered from USB or any 7V-15V external power source
- **USB**
 - USB-JTAG Programming circuitry
 - USB-UART Bridge
- **Switches, Push-buttons, and LEDs**
 - 4 Switches
 - 4 Buttons
 - 1 Reset Button
 - 4 LEDs
 - 2 RGB LEDs
- **Expansion Connectors**
 - 4 Pmod ports
 - 32 total FPGA I/O (16 shared with shield connector)
 - Arduino/chipKIT Shield connector
 - 45 total FPGA I/O (16 shared with Pmod connectors)
 - 6 Single-ended 0-3.3V Analog inputs to XADC
 - 3 Differential 0-1.0V Analog input pairs to XADC

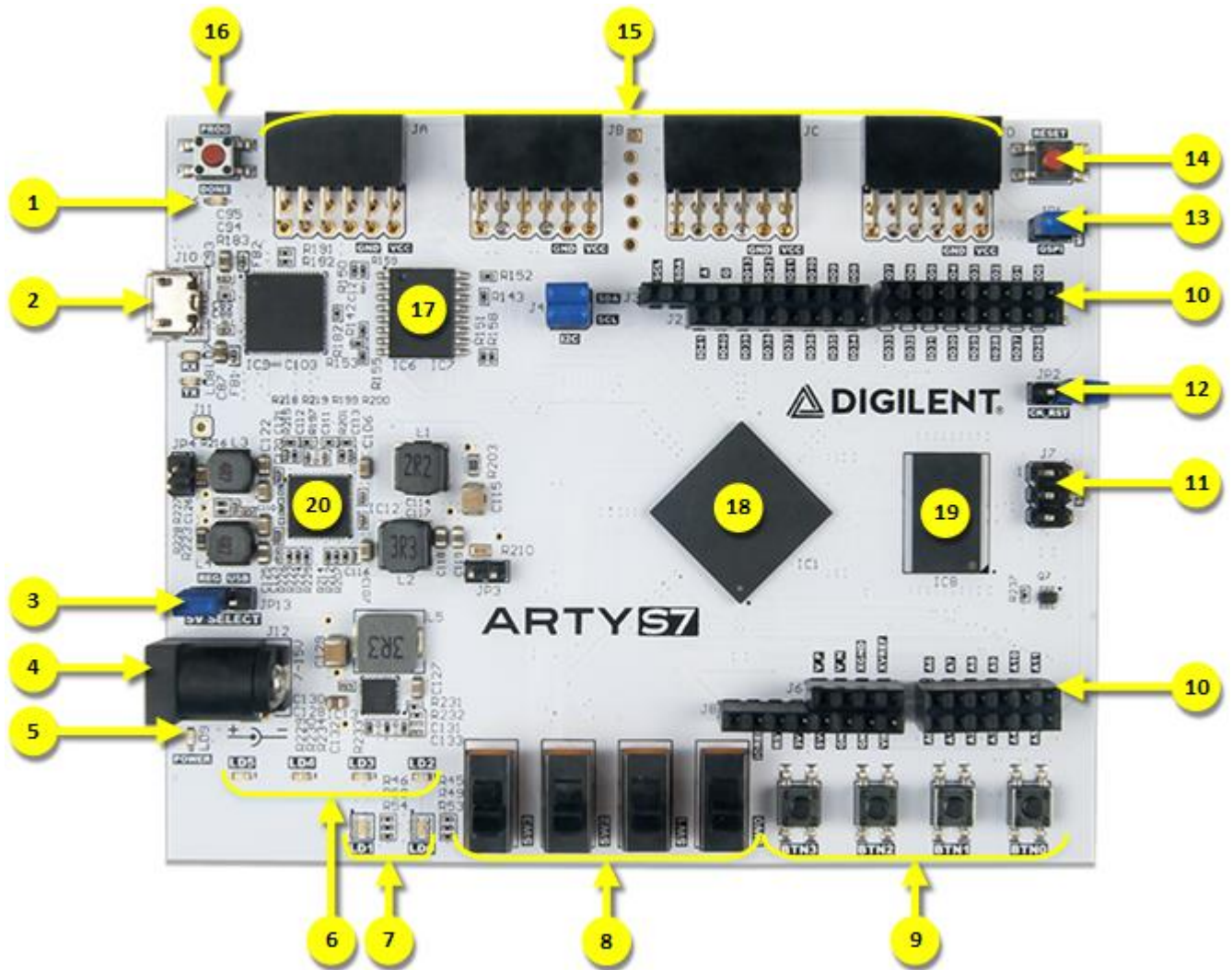

CalloutDescription

- 1 FPGA programming DONE LED
- 2 Shared USB JTAG / UART port
- 3 Power select jumper (Ext. supply / USB)
- 4 Power jack (for optional ext. supply)
- 5 Power good LED
- 6 User LEDs
- 7 User Tri color LEDs
- 8 User slide switches
- 9 User push buttons
- 10 Arduino/ChipKIT shield connectors

CalloutDescription

- 11 SPI header (Arduino/ChipKIT compatible)
- 12 Arduino IDE reset jumper
- 13 FPGA programming mode (JTAG/ Flash)
- 14 Processor reset
- 15 Pmod headers
- 16 FPGA programming reset button
- 17 SPI Flash
- 18 Spartan-7 FPGA
- 19 DDR3L memory
- 20 Analog devices ADP 5052 power supply

Purchasing Options

The board is sold standalone, but requires either a micro USB cable or 7-15V external power supply to be powered. The external power supply must have a coaxial, center-positive connector with 2.1 mm or 2.5 mm internal diameter. When purchased from Digilent, a micro USB cable or suitable 12V, 3A power supply can added at the time of purchase.

You may see the Arty S7 referred to as the Arty S7-50 throughout some Digilent documentation. This is to distinguish it from future variants of the Arty S7 that will be loaded with different versions of the Spartan-7. These variants are not available yet.

Software Support

The Arty S7 is fully compatible with the high-performance Vivado® Design Suite. It is supported under the free WebPACK™ license, so designs can be implemented at no additional cost. This free license includes the ability to create MicroBlaze™ soft-core processor designs, the Logic Analyzer, and High-level Synthesis (HLS). The Logic Analyzer assists with debugging logic, and the HLS tool allows you to compile C code directly into HDL. Design resources, example projects, and tutorials are available for download at the [Arty S7 Resource Center](#).

Designing with Microblaze

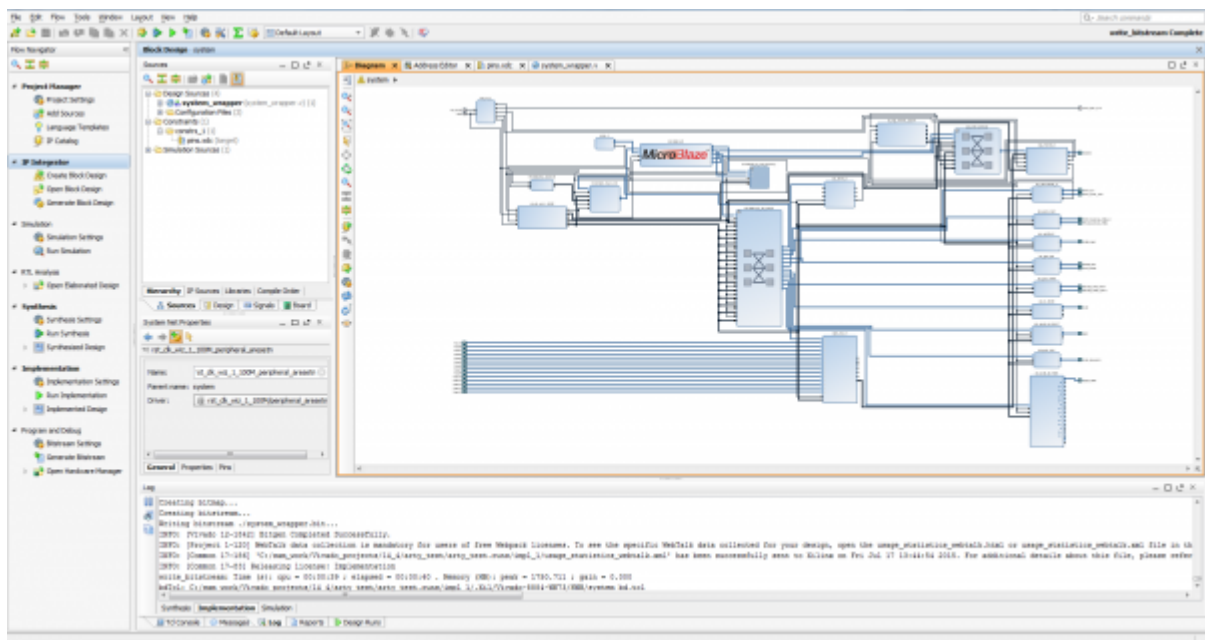

What makes the Arty S7 so flexible is its FPGA. Among their many features, FPGAs have the ability to transform into a custom software-defined System-on-a-Chip (SoC). These “Soft SoC” FPGA configurations are designed graphically using a tool called Vivado IP Integrator (Vivado IPI). In this tool, pre-built peripheral blocks are dragged from an extensive library and dropped into your processing system as you see fit. These pre-built peripherals include timers, UART/SPI/IIC controllers, and many of the other devices you would typically find in an SoC or microcontroller. Ambitious users will also find that they can create their own peripheral blocks by writing them in a

Hardware Definition Language (HDL), specifically Verilog or VHDL. For those with no interest in learning HDL, the Xilinx High Level Synthesis tool can be used to define custom peripheral blocks by writing them in C.

The Arty S7's Soft SoC configurations are powered by MicroBlaze processor cores. MicroBlaze is a 32-bit RISC soft processor core, designed specifically to be used in Xilinx FPGAs. The MicroBlaze processor in an Arty S7 SoC configuration is typically run at 100 MHz, though it is possible to design your SoC so that it can operate at over 200MHz. The Arty S7 supports large MicroBlaze programs with demanding memory requirements by providing 16MB of non-volatile program memory and 256MB of DDR3L RAM.

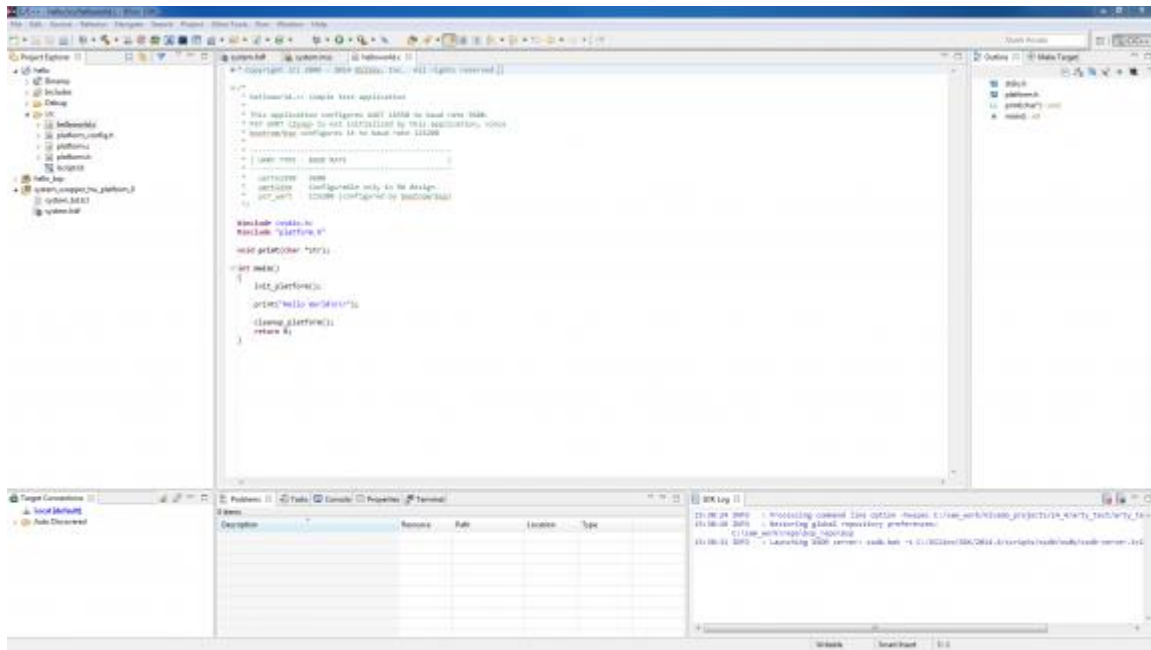

After you design your soft SoC configuration for the Arty S7 you can start writing programs for it. This is done by exporting your SoC design out of Vivado IPI and into the Xilinx Software Development Kit (XSDK), an Integrated Development Environment (IDE) for designing/debugging MicroBlaze programs in C and C++. After the IPI to XSDK handoff, XSDK is automatically configured to include libraries and examples for the peripheral blocks you've included in your SoC. At this point, programming the Arty S7 is very similar to programming other SoC or microcontroller platforms: Programs are written in C, programmed into board over USB, and then optionally debugged in hardware. Soft SoC configurations and MicroBlaze programs can also be loaded into the 16MB non-volatile program memory so that they execute immediately after Arty S7 is powered on.

Although the Arty S7 is particularly well suited for Microblaze Soft SoC designs, it can also be programmed with a Register-Transfer Level (RTL) circuit description like any other FPGA development platform. This design flow requires that you describe your RTL circuit using an HDL within Vivado, and it does not use the Vivado IPI or XSDK tools. Designing this way has many advantages, but is very unlike programming a single board computer, and instead is used by those familiar with FPGA design or interested in designing and implementing a digital circuit that doesn't contain a processor.

Functional Description

1 Power Supplies

The Arty S7 board requires a 5 volt power source to operate. This power source can come from the Digilent USB-JTAG port (J10) or it can be derived from a 7 to 15 Volt DC power supply that's connected to the Power Jack (J12) or Pin 8 of Header J7. Header JP13, labeled "5V SELECT", is used to determine which source is used.

A power-good LED (LD9), driven by the "power good" (PWRGD) output of the ADP5052 regulator, indicates that the board is receiving power and that the onboard supplies are functioning as expected. If this LED does not illuminate when an acceptable power supply is connected and selected with JP13, please contact your distributor or [Digilent Support](#) for further help.

An overview of the Arty S7 power circuit is shown below.

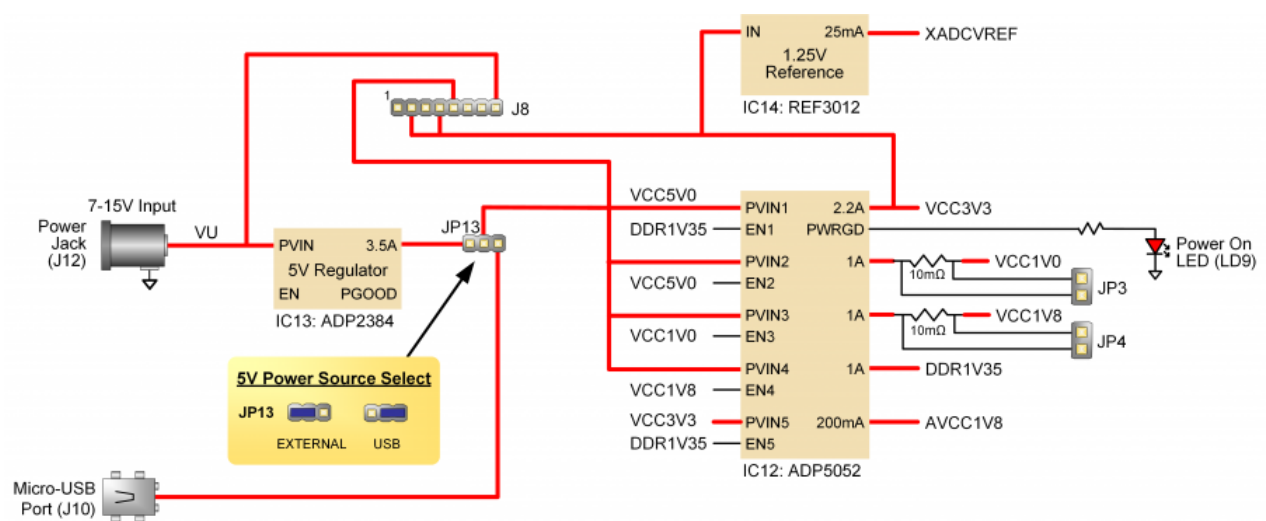

Figure 1.1. Arty S7 Power Circuit.

The USB port can deliver enough power for the vast majority of designs. However, a few demanding applications, including any that drive multiple peripheral boards, might require more power than the USB port can provide. Also, some applications may need to run without being connected to a PC's USB port. In these instances an external power supply or battery pack can be used.

An external power supply can be used by plugging into Power Jack J12 and installing a jumper in the "REG" position on Header JP13. The supply must use a coaxial, center-positive 2.1mm (or 2.5mm) internal-diameter plug, and provide a voltage of 7 to 15 Volts DC. The supply should provide a minimum current of 1 amp. Ideally, the supply should be capable of providing 36 Watts of power (12 Volts DC, 3 amps).

An external battery pack can be used by connecting the battery's positive terminal to pin 8 of J7 (labeled VIN) and the negative terminal to pin 7 of J7 (labeled GND), as shown in Figure 1.2. In order to use the battery pack as the board's power source a jumper must be installed in the "REG" position on Header J13. The battery must provide a voltage between 7 and 15 volts DC, and should NOT be installed while there is a supply connected to Power Jack J12.

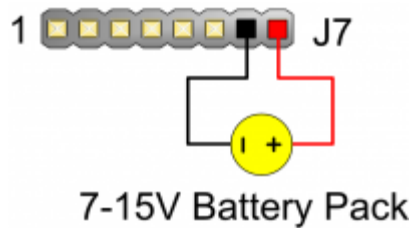

Figure 1.2. Arty S7 Battery Pack Connection.

Voltage regulator circuits from Analog Devices and Texas Instruments create the required 3.3V, 1.8V, 1.35V, 1.25V, and 1.00V supplies from the 5V power source. In the event that an external supply or battery pack is used, the on-board Analog Devices 5V regulator provides the 5V source. Table 1.1 provides additional information (typical currents depend strongly on FPGA configuration and the values provided are typical of medium size/speed designs).

Supply	Circuits	Device	Current (max/typical)
5V	Onboard Regulators, RGB LEDs	IC13: Analog Devices ADP2384	3.5A/0.375A to 2A
3.3V	FPGA I/O, Clocks, Flash, PMODs, LEDs, Buttons, Switches, USB port	IC12: Analog Devices ADP5052	2.2A/NA
1.00V	FPGA Core and Block RAM	IC12: Analog Devices ADP5052	1.0A/0.2A to 0.8A
1.8V	FPGA Auxiliary	IC12: Analog Devices ADP5052	1.0A/NA
1.35V	DDR3L and associated FPGA bank	IC12: Analog Devices ADP5052	1.0A/NA
1.25V	XADC Analog Reference	IC14: Texas Instruments REF3012	25mA/NA

Table 1.1. Arty S7 Power Rails.

1.1 Current Monitoring

The 1.0V and 1.8V rails each have a 0.010 Ohm current sense resistor for monitoring the amount of current being consumed by them. You can access them via JP3 for the 1.0V rail and JP4 for the 1.8V rail. To calculate the current on each power rail, use Ohm's law with $R=0.010$ and V equal to the measured voltage across the jumper. To measure the voltage you can use an external digital multimeter or oscilloscope.

2 FPGA Configuration

After power-on, the Spartan-7 FPGA must be configured (or programmed) before it can perform any functions. You can configure the FPGA in one of two ways:

1. A PC can use the Digilent USB-JTAG circuitry (port J10) to program the FPGA any time the power is on.
2. A file stored in the nonvolatile serial (SPI) flash device can be transferred to the FPGA using the SPI port.

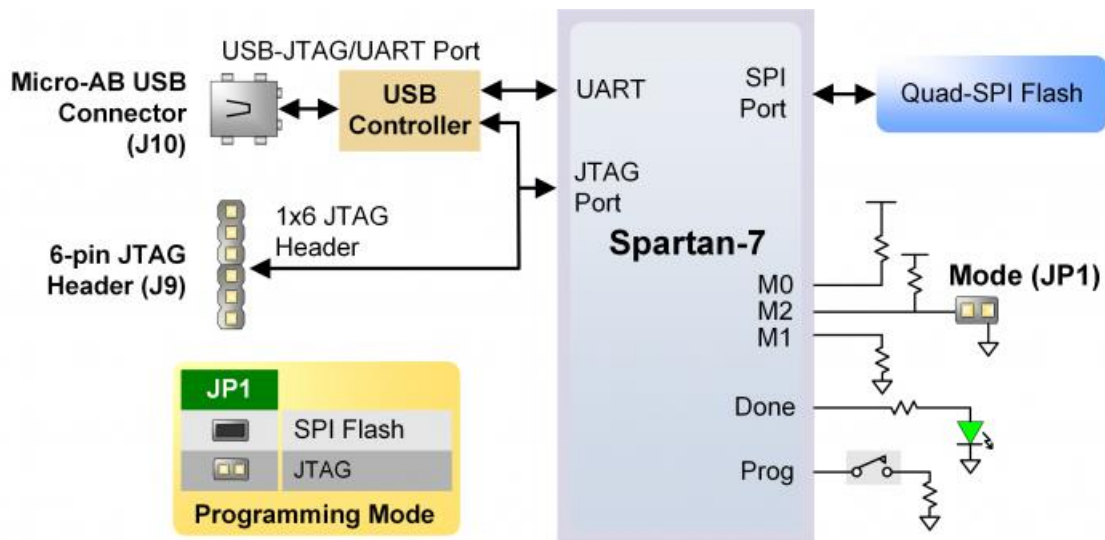

Figure 2.1. Arty S7 FPGA Configuration.

Figure 2.1 shows the different options available for configuring the FPGA. An on-board “mode” jumper (JP1) selects whether the FPGA will be programmed by the Quad-SPI flash on power up.

The FPGA configuration data is stored in files called bitstreams that have the .bit file extension. The Vivado software from Xilinx can create bitstreams from VHDL, Verilog®, or block-level design.

Bitstreams are stored in volatile memory cells within the FPGA. This data defines the FPGA’s logic functions and circuit connections, and it remains valid until it is erased by removing board power, by pressing the reset button attached to the PROG input, or by writing a new configuration file using the JTAG port.

A Spartan-7 50T bitstream is typically 17,536,096 bits. The time it takes to program the Arty S7 can be decreased by compressing the bitstream before programming, and then allowing the FPGA to decompress the bitstream itself during configuration. Depending on design complexity, compression ratios of 10x can be achieved. Bitstream compression can be enabled within the Xilinx tools to occur during generation. For instructions on how to do this, consult the Xilinx documentation for the toolset being used.

After being successfully programmed, the FPGA will cause the “DONE” LED to illuminate. Pressing the “PROG” button at any time will reset the configuration memory in the FPGA. After being reset, if JP1 is set then the FPGA will immediately attempt to reprogram itself from Quad SPI flash.

The following sections provide greater detail about programming the Arty S7 using the different methods available.

2.1 JTAG Configuration

The Xilinx tools typically communicate with FPGAs using the Test Access Port and Boundary-Scan Architecture, commonly referred to as JTAG. During JTAG programming, a .bit file is transferred from the PC to the FPGA using the onboard Digilent USB-JTAG circuitry (port J10) or an external JTAG programmer, such as the Digilent JTAG-HS2, attached to port J9. You can perform JTAG programming any time after the Arty S7 has been powered on, regardless of whether the mode jumper (JP1) is set. If the FPGA is already configured, then the existing configuration is overwritten with the bitstream being transmitted over JTAG. Not setting the mode jumper (seen in Figure 2.1) is useful to prevent the FPGA from being configured from Quad-SPI Flash until a JTAG programming occurs.

Programming the Arty S7 with an uncompressed bitstream using the on-board USB-JTAG circuitry usually takes around 6 seconds. JTAG programming can be done using the hardware manager in Vivado.

2.2 Quad-SPI Configuration

Since the FPGA's memory on the Arty S7 is volatile, it relies on the Quad-SPI flash memory to store the configuration between power cycles. This configuration mode is called Master SPI. The blank FPGA takes the role of master and reads the configuration file out of the flash device upon power-up. To that effect, a configuration file needs to be downloaded first to the flash. When programming a non-volatile flash device, a bitstream file is transferred to the flash in a two-step process. First, the FPGA is programmed with a circuit that can program flash devices, and then data is transferred to the flash device via the FPGA circuit (this complexity is hidden from the user by the Xilinx tools). This is called indirect programming. After the flash device has been programmed, it can automatically configure the FPGA at a subsequent power-on or reset event as determined by the mode jumper setting (see Figure 2.1). Programming files stored in the flash device will remain until they are overwritten, regardless of power-cycle events.

Programming the flash can take as long as four to five minutes, which is mostly due to the lengthy erase process inherent to the memory technology. Once written however, FPGA configuration can be very fast—less than a second. Bitstream compression, SPI bus width, and configuration rate are factors controlled by the Xilinx tools that can affect configuration speed. The Arty S7 supports x1, x2, and x4 bus widths and data rates of up to 50 MHz for Quad-SPI programming.

Quad-SPI programming can be done using the hardware manager in Vivado.

3 DDR3L Memory

The Arty S7 includes one MT41K128M16JT-125 memory component, creating a single rank, 16-bit wide interface. It is routed to a 1.35V-powered HR (High Range) FPGA bank with 50 ohm controlled single-ended trace impedance. 50 ohm internal terminations in the FPGA are used to match the trace characteristics. Similarly, on the memory side, on-die terminations (ODT) are used for impedance matching.

For proper operation of the memory, a memory controller and physical layer (PHY) interface needs to be included in the FPGA design. The easiest way to accomplish this on the Arty S7 is to use the Xilinx 7-series memory interface solutions core generated by the MIG (Memory Interface Generator) Wizard. The MIG Wizard can generate a native FIFO-style or an AXI4 interface to connect to user logic. This workflow allows the customization of several DDR parameters optimized for the particular application. Table 3.1 below lists the MIG Wizard settings optimized for the Arty S7 (any settings not mentioned can be left in default state).

Setting	Value
Memory type	DDR3 SDRAM
Max. clock period	3077ps (650Mbps data rate)
Memory part	MT41K128M16XX-15E
Memory Voltage	1.35V
Data width	16
Data mask	Enabled
Recommended Input Clock Period	10000ps (100.000 MHz)
Output Driver Impedance Control	RZQ/6
Controller Chip Select pin	Enabled
Rtt (nominal) – On-die termination	RZQ/6
Internal Vref	Enabled
Internal termination impedance	50ohms

Table 3.1. DDR3L settings for the Arty S7.

For clocking, it is recommending that the System clock be set to “Single-ended”, and connected directly to the onboard 100MHz oscillator on pin R2. The Reference clock should be set to “no buffer” and can be connected to a 200 MHz clock generated from a clocking wizard elsewhere in

the design. It is also possible to generate the reference clock from the MIG itself by enabling “Select Additional Clocks” and generating a clock with a 5007 ps period (199.69231 MHz). This clock will be within spec for the reference clock requirements, and can be looped around back into the reference clock input of the MIG IP core.

The MIG Wizard will require the fixed pin-out of the memory signals to be entered and validated before generating the IP core. For your convenience, an importable UCF file is provided on the Arty S7 resource center to speed up this process. It is included in the digilent-mig repository on the [Digilent Github](#). This download also includes a .prj file that can be imported into the wizard to automatically configure it with the options found in Table 3.1.

For those using the MIG with a MicroBlaze project, it is not necessary to use the files found in the digilent-mig repository. Instead, the Arty S7 MIG settings and pinout will be automatically imported from the [Digilent Vivado board files](#).

For more details on the Xilinx MIG, refer to the 7 Series FPGAs Memory Interface Solutions User Guide (ug586).

4 Quad-SPI Flash

FPGA configuration files can be written to the Quad-SPI Flash (Spansion part number S25FL128S), and setting the mode jumper will cause the FPGA to automatically read a configuration from this device at power on. A Spartan-7 50T configuration file requires 17,536,096 bits of memory, leaving about 87% of the flash device (or ~13.92 MB) available for user data. A common use for this extra memory is to store Microblaze programs too big to fit in the onboard Block memory (typically 128 KB). These programs are then loaded and executed using a smaller bootloader program that can fit in the block memory. It is possible to automatically generate this bootloader, roll it into your bitstream, and then program the bitstream and large microblaze program into the Quad SPI Flash using Xilinx SDK.

The contents of the memory can be manipulated by issuing certain commands on the SPI bus. The implementation of this protocol is outside the scope of this document. Xilinx’s AXI Quad SPI core can be used to read/write the flash in a Microblaze design. Refer to Xilinx’s product guide for this core to learn more about using it, or to Spansion’s datasheet for the flash device to learn how to implement a custom controller.

All signals in the SPI bus are general-purpose user I/O pins after FPGA configuration and can be used like any other FPGA I/O, except for SCK. It can only be accessed by instantiating a special primitive called STARTUPE2. The Xilinx AXI Quad SPI IP core has a configuration option that will automatically instantiate the primitive for you, and this option should be enabled when using it with the Arty S7. For information on instantiating the primitive from HDL, refer to the “Vivado Design Suite 7 Series FPGA and Zynq-7000 All Programmable SoC Libraries Guide” (UG953) from Xilinx.

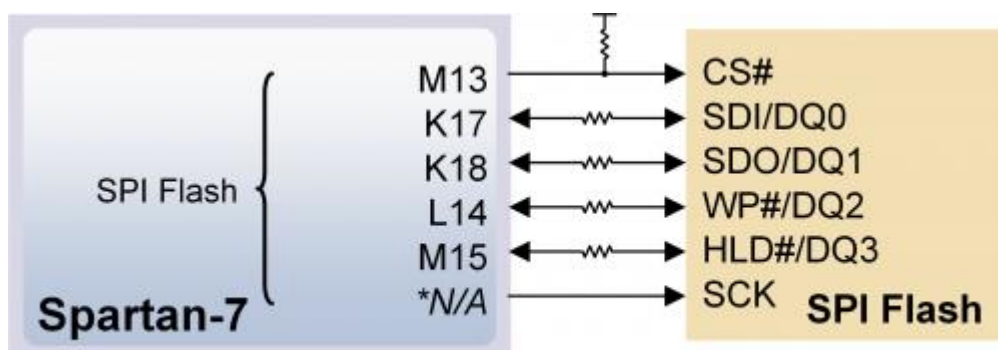

*The SCK Signal can only be accessed via the STARTUPE2 primitive

Figure 4.1. Arty S7 SPI flash.

5 Oscillators/Clocks

The Arty S7 board includes a 12 MHz crystal oscillator connected to pin F14 (an MRCC input on bank 15) and a 100 MHz crystal oscillator connected to pin R2 (an MRCC input on bank 34).

The 12 MHz clock is intended to be used as a general purpose system clock. The clock can drive MMCMs to generate clocks of various frequencies and with known phase relationships that may be needed throughout a design. The 12 MHz input clock cannot directly drive a PLL because they have a minimum input frequency of 19 MHz. Some rules restrict which MMCMs and PLLs may be driven by the 12 MHz input clock. For a full description of these rules and of the capabilities of the Spartan-7 clocking resources, refer to the “7 Series FPGAs Clocking Resources User Guide” available from Xilinx.

Xilinx offers the Clocking Wizard IP core to help users generate the different clocks required for a specific design. This wizard will properly instantiate the needed MMCMs and PLLs based on the desired frequencies and phase relationships specified by the user. The wizard will then output an easy-to-use wrapper component around these clocking resources that can be inserted into the user’s design. The clocking wizard can be accessed from within the Vivado and IP Integrator tools.

The 100 MHz clock is intended to drive the system clock input of the Memory Interface Generator (MIG) IP Core to allow for proper use of the DDR3L memory. Section 3 “DDR3L Memory” describes how to use this clock properly with the MIG. For complete information on using the MIG, see the 7 Series FPGAs Memory Interface Solutions User Guide (ug586) from Xilinx.

6 USB-UART Bridge (Serial Port)

The Arty S7 includes an FTDI FT2232HQ USB-UART bridge (attached to connector J10) that allows you to use PC applications to communicate with the board using standard Windows COM port commands. Free USB-COM port drivers, available from www.ftdichip.com under the “Virtual Com Port” or VCP heading, convert USB packets to UART/serial port data. Serial port data is exchanged with the FPGA using a two-wire serial port (TXD/RXD). After the drivers are installed, I/O commands can be used from the PC directed to the COM port to produce serial data traffic on the V12 and R12 FPGA pins.

Two on-board status LEDs provide visual feedback on traffic flowing through the port: the transmit LED (LD8) and the receive LED (LD7). Signal names that imply direction are from the point-of-view of the DTE (Data Terminal Equipment), in this case the PC.

The FT2232HQ is also used as the controller for the Digilent USB-JTAG circuitry, but the USB-UART and USB-JTAG functions behave entirely independent of one another. Programmers interested in using the UART functionality of the FT2232 within their design do not need to worry about the JTAG circuitry interfering with the UART data transfers, and vice-versa. The combination of these two features into a single device allows the Arty S7 to be programmed, communicated with via UART, and powered from a computer attached with a single Micro USB cable.

The CK_RST signal (see the Arty S7 Schematic) is also connected to the FT2232HQ device via JP2. When JP2 is shorted, the FT2232HQ can trigger a Microblaze reset, mimicking the behavior of Arduino and chipKIT boards when sketches are loaded. Note the CK_RST signal is also connected to the red RESET button and the RST pin of J7 on the shield connector (these connections are not shown in Figure 6.1). It is recommended that this jumper is not shorted unless attempting to run Arduino IDE on Microblaze, because it can interfere with normal Microblaze function.

The connections between the FT2232HQ and the Spartan-7 are shown in Figure 6.1.

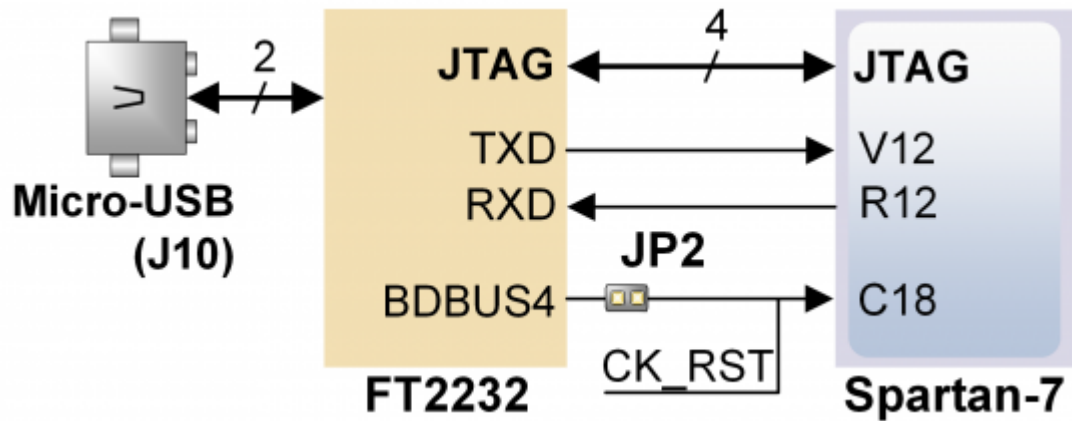

Figure

6.1. UART Connections.

7 Basic I/O

The Arty S7 board includes two tri-color LEDs, 4 switches, 4 push buttons, 4 individual LEDs, and a reset button, as shown in Figure 8.1. The push buttons and slide switches are connected to the FPGA via series resistors to prevent damage from inadvertent short circuits (a short circuit could occur if an FPGA pin assigned to a push button or slide switch was inadvertently defined as an output). The four push buttons are “momentary” switches that normally generate a low output when they are at rest, and a high output only when they are pressed. Slide switches generate constant high or low inputs depending on their position.

The red reset button labeled “RESET” generates a high output when at rest and a low output when pressed. The RESET button is intended to be used in Microblaze designs to reset the processor, but you can also use it as a general purpose push button. Note that it is also tied to the RST pin on J7 of the shield connector and to the FT2232 UART device via JP2, though these connections are not shown in the figure below.

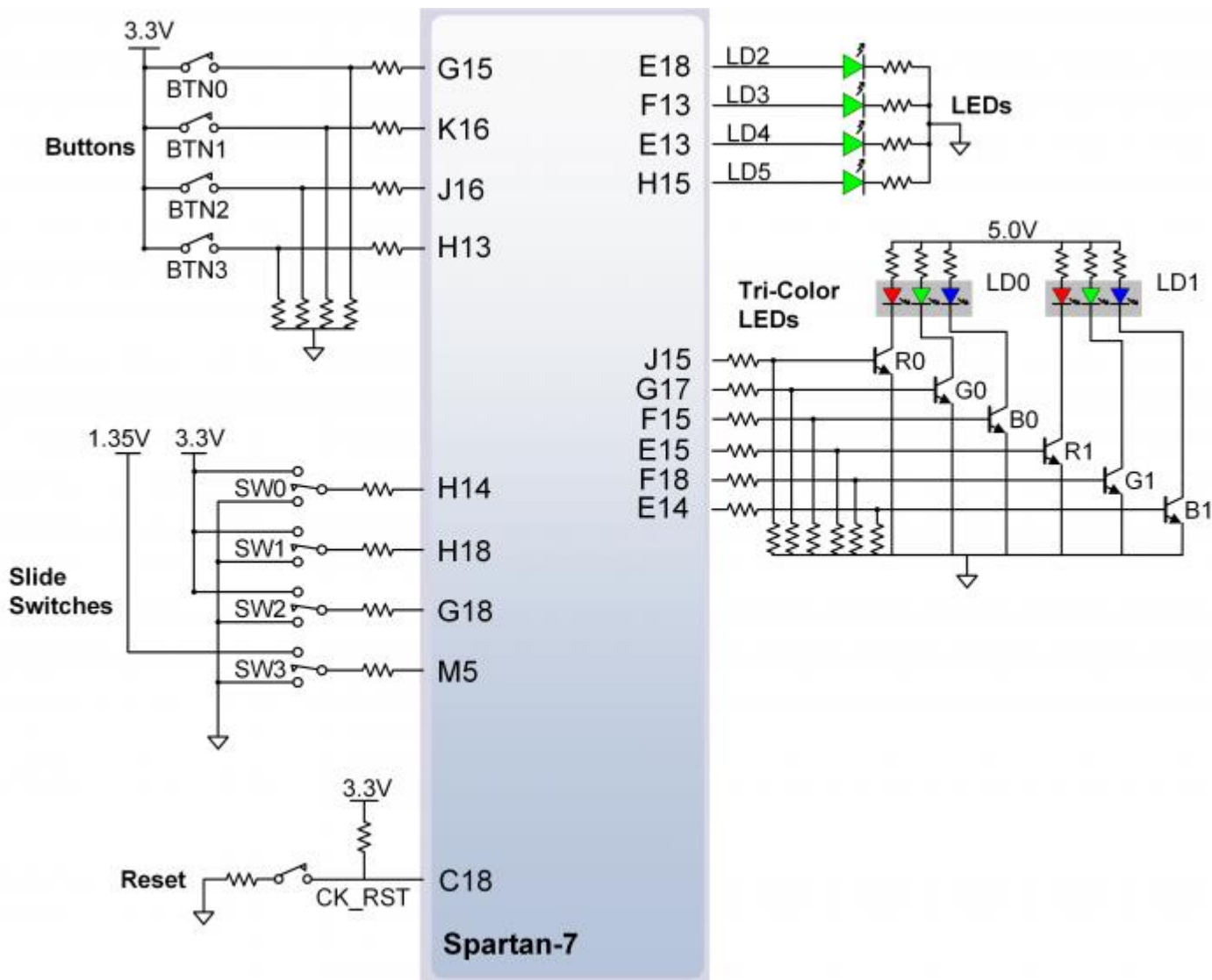

Figure 7.1. Arty S7 GPIO.

The four individual high-efficiency LEDs are anode-connected to the FPGA via 330-ohm resistors, so they will turn on when a logic high voltage is applied to their respective I/O pin. Additional LEDs that are not user-accessible indicate power-on, FPGA programming status, and USB and Ethernet port status.

7.1 Tri-Color LEDs

The Arty S7 board contains two tri-color LEDs. Each tri-color LED has three input signals that drive the cathodes of three smaller internal LEDs: one red, one blue, and one green. Driving the signal corresponding to one of these colors high will illuminate the internal LED. The input signals are driven by the FPGA through a transistor, which inverts the signals. Therefore, to light up the tri-color LED, the corresponding signals need to be driven high. The tri-color LED will emit a color dependent on the combination of internal LEDs that are currently being illuminated. For example, if the red and blue signals are driven high and green is driven low, the tri-color LED will emit a purple color.

Note: Digilent strongly recommends the use of pulse-width modulation (PWM) when driving the tri-color LEDs. Driving any of the inputs to a steady logic '1' will result in the LED being illuminated at an uncomfortably bright level. You can avoid this by ensuring that none of the tri-color signals are driven with more than a 50% duty cycle. Using PWM also greatly expands the potential color palette of the tri-color LED. Individually adjusting the duty cycle of each color between 50% and

0% causes the different colors to be illuminated at different intensities, allowing virtually any color to be displayed.

8 Pmod Connectors

Pmod connectors are 2x6, right-angle, 100-mil spaced female connectors that mate with standard 2x6 pin headers. Each 12-pin Pmod connector provides two 3.3V VCC signals (pins 6 and 12), two Ground signals (pins 5 and 11), and eight logic signals, as shown in Figure 8.1. The VCC and Ground pins can deliver up to 1A of current, but care must be taken not to exceed any of the power budgets of the onboard regulators or the external power supply (these are described in the “Power supplies” section).

Digilent produces a large collection of Pmod accessory boards that can attach to the Pmod expansion connectors to add ready-made functions like A/D’s, D/A’s, motor drivers, sensors, and other functions. See www.digilentinc.com for more information.

The Arty S7 has four Pmod connectors, some of which behave differently than others. Each Pmod connector falls into one of two categories: standard or high-speed. Also, some Pmod connectors share their connections with the inner rows of the shield connector, and should not be used at the same time as a shield that requires those pins. Table 8.1 specifies which category each Pmod falls into, whether it shares any pins with the shield connector, and also lists the FPGA pins they are connected to. The following sections describe the different types of Pmods.

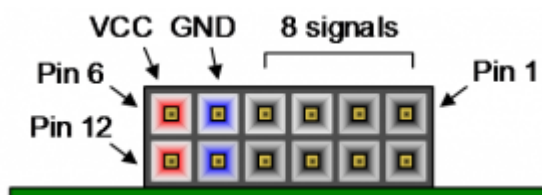

Figure 8.1. Pmod connector.

	Pmod JA	Pmod JB	Pmod JC	Pmod JD
Pmod Type	High-Speed	High-Speed	Standard	Standard
Shared pins	–	–	IO34-IO41	IO26-IO33
Pin 1	L17	P17	U15	V15
Pin 2	L18	P18	V16	U12
Pin 3	M14	R18	U17	V13
Pin 4	N14	T18	U18	T12
Pin 7	M16	P14	U16	T13
Pin 8	M17	P15	P13	R11
Pin 9	M18	N15	R13	T11
Pin 10	N18	P16	V14	U11

Table 8.1. Arty S7 Pmod Pinout.

8.1 Standard Pmod

The standard Pmod connectors are connected to the FPGA via 200 Ohm series resistors. The series resistors prevent short circuits that can occur if the user accidentally drives a signal that is supposed to be used as an input. The downside to this added protection is that these resistors can limit the maximum switching speed of the data signals. If the Pmod being used does not require high-speed access, then the standard Pmod connector should be used to help prevent damage to the devices.

8.2 High-Speed Pmod

The High-speed Pmods use the standard Pmod connector, but have their data signals routed as impedance matched differential pairs for maximum switching speeds. They have pads for loading resistors for added protection, but the Arty S7 ships with these loaded as 0-Ohm shunts. With the series resistors shunted, these Pmods offer no protection against short circuits, but allow for much faster switching speeds. The signals are paired to the adjacent signals in the same row: pins 1 and 2, pins 3 and 4, pins 7 and 8, and pins 9 and 10.

Traces are routed 100 ohm (+/- 10%) differential.

These connectors should be used only when high speed differential signaling is required or the other Pmods are all occupied. If used as single-ended, coupled pairs may have significant crosstalk. In applications where this is a concern, the standard Pmod connector shall be used. Another option would be to ground one of the signals (drive it low from the FPGA) and use its pair for the signal-ended signal.

Since the High-Speed Pmods have 0-ohm shunts instead of protection resistors, the operator must take precaution to ensure that they do not cause any shorts.

9 Arduino/chipKIT Shield Connector

The Arty S7 can be connected to standard Arduino and chipKIT shields to add extended functionality. Special care was taken while designing the Arty S7 to make sure it is compatible with the majority of Arduino and chipKIT shields on the market. The shield connector has 45 pins connected to the FPGA for general purpose Digital I/O. Due to the flexibility of FPGAs, it is possible to use these pins for just about anything including digital read/write, SPI connections, UART connections, I2C connections, and PWM. Six of these pins (labeled AN0-AN5) can also be used as single-ended analog inputs with an input range of 0V-3.3V, and another four (labeled AN6-9) can be used as differential analog input pairs with an input range of 0V-1.0V.

Note: The Arty S7 is not compatible with shields that output 5V digital or analog signals. Driving pins on the Arty S7 shield connector above 5V may cause damage to the FPGA.

Figure 9.1 diagrams the pins found on the shield connector of the Arty S7.

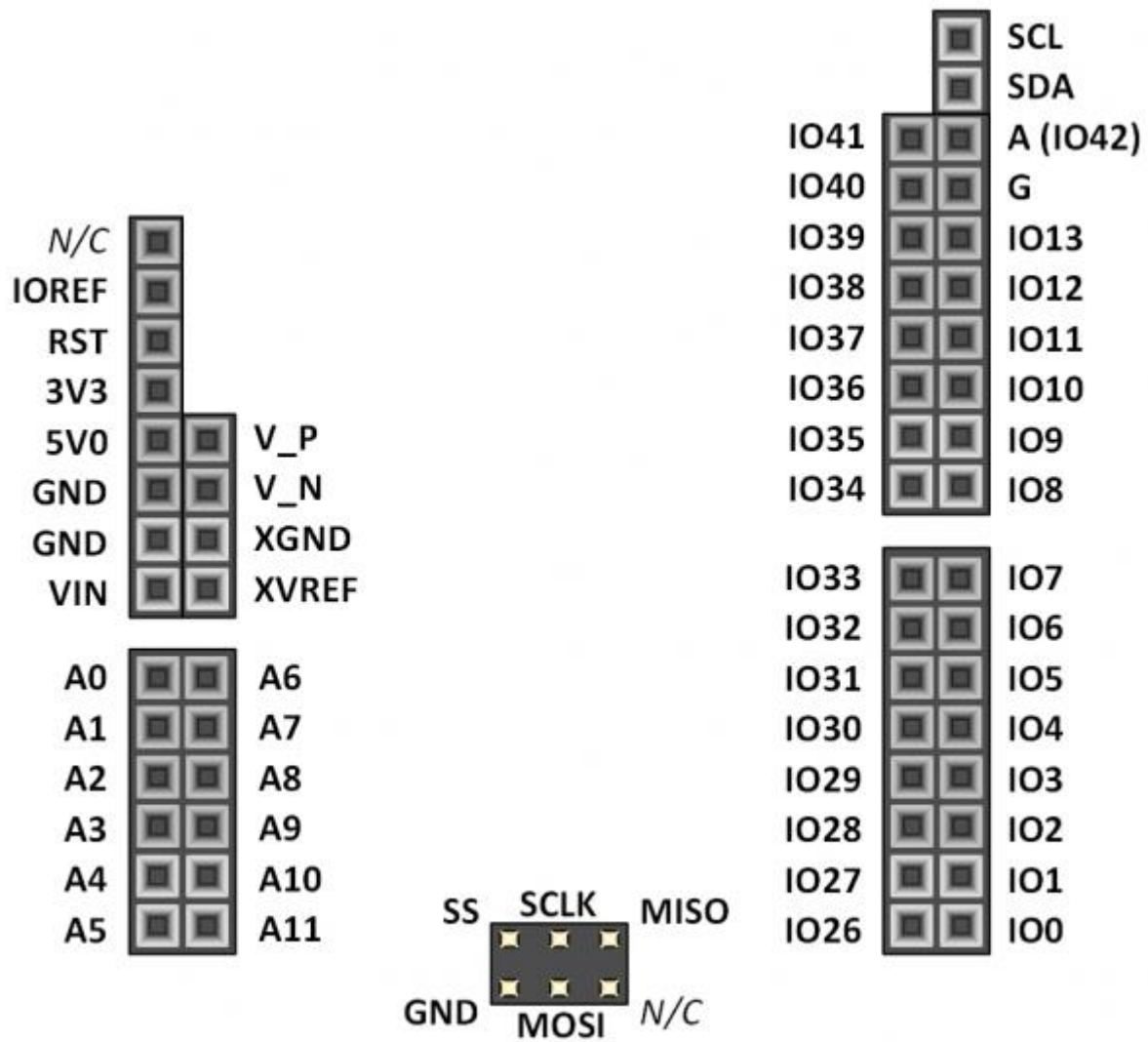

Figure 9.1. Shield connector pin diagram.

Pin Name	Shield Function	Arty S7 Connection	Shared Connections
IO0-IO09, A (IO42), A10-A11	General purpose I/O pins	See Section titled "Shield Digital I/O"	–
IO26-IO33	General purpose I/O pins	See Section titled "Shield Digital I/O"	Pmod JD
IO34-IO41	General purpose I/O pins	See Section titled "Shield Digital I/O"	Pmod JC
SCL	I2C Clock	See Section titled "Shield Digital I/O"	–
SDA	I2C Data	See Section titled "Shield Digital I/O"	–
IO13	General purpose I/O, SPI Clock	See Section titled "Shield Digital I/O"	SCLK pin of SPI Connector
IO11	General purpose I/O, SPI Data out	See Section titled "Shield Digital I/O"	MOSI pin of SPI Connector
IO12	General purpose I/O, SPI Data in	See Section titled "Shield Digital I/O"	MISO pin of SPI Connector
IO10	General purpose I/O, SPI Slave Select	See Section titled "Shield Digital I/O"	SS pin of SPI Connector
A0-A5	Single-Ended Analog Input	See Section titled "Shield Analog I/O"	–

Pin Name	Shield Function	Arty S7 Connection	Shared Connections
A6-A9	Differential Analog Input Dedicated	See Section titled "Shield Analog I/O"	—
V_P, V_N	Differential Analog Input	See Section titled "Shield Analog I/O"	—
XGND	XADC Analog Ground	Connected to net used to drive the XADC ground reference on the FPGA (VREFN)	—
XVREF	XADC Analog Voltage Reference	Connected to 1.25 V, 25mA rail used to drive the XADC voltage reference on the FPGA (VREFP)	—
N/C	Not Connected	Not Connected	—
IOREF	Digital I/O Voltage reference	Connected to the Arty S7 3.3V Power Rail (See the "Power Supplies" section)	—
RST	Reset to Shield	Connected to the red "RESET" button and a Digital I/O of the FPGA. When JP2 is shorted, it is also connected to the DTR signal of the FTDI USB-UART bridge.	—
3V3	3.3V Power Rail	Connected to the Arty S7 3.3V Power Rail (See the "Power Supplies" section)	—
5V0	5.0V Power Rail	Connected to the Arty S7 5.0V Power Rail (See the "Power Supplies" section)	—
GND, G	Ground	Connected to the Ground plane of Arty S7 Connected in parallel with the external power supply connector (J12). See the "Power Supplies" section for information on powering the	—
VIN	Power Input	Arty S7 from this pin.	—

Table 9.1. Arty S7 Shield Pinout

9.1 Shield Digital I/O

The pins connected directly to the FPGA can be used as general purpose inputs or outputs. These pins include the I2C, SPI, and general purpose I/O pins. There are 200 Ohm series resistors between the FPGA and the digital I/O pins to help provide protection against accidental short circuits (pins A10 and A11 instead have 140 Ohm series resistors). The absolute maximum and recommended operating voltages for these pins are outlined in Table 9.1.1.

	Absolute Minimum Voltage	Recommended Minimum Voltage	Recommended Operating Maximum Voltage	Absolute Maximum Voltage
Powered	-0.4 V	-0.2 V	3.4 V	3.75 V
Unpowered	-0.4 V	N/A	N/A	0.55 V

Table 9.1.1. Shield Voltage Specifications

For more information on the electrical characteristics of the pins connected to the FPGA, please see the [Spartan-7 datasheet](#) from Xilinx.

The pins on the shield connector typically used for I2C signals are labeled as SCL and SDA. When using these signals to implement an I2C bus it is necessary to attach a pull-up resistor to them. On the Arty S7, this can be done by placing two shorting blocks horizontally across the J4 header.

9.2 Shield Analog I/O

The pins labeled A0-A9 and V_P/V_N are used as analog inputs to the XADC module of the FPGA. The FPGA expects that the inputs range from 0-1 V. On the pins labeled A0-A5 we use an external circuit to scale down the input voltage from 3.3V. This circuit is shown in Figure 9.2.1. This circuit allows the XADC module to accurately measure any voltage between 0V and 3.3V (relative to the

Arty S7's GND) that is applied to any of these pins. If you wish to use the pins labeled A0-A5 as Digital inputs or outputs, they are also connected directly to the FPGA before the resistor divider circuit (also shown in Figure 9.2.1).

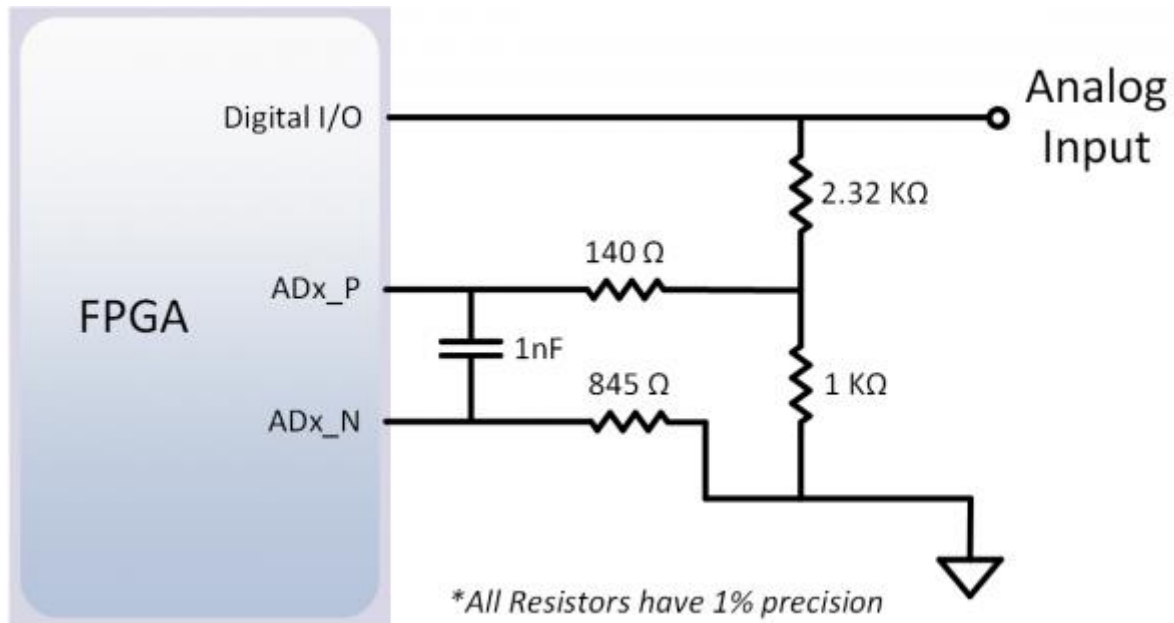

Figure 9.2.1. Single-Ended Analog Inputs

The pins labeled A6-A9 are connected directly to 2 pairs of analog capable pins on the FPGA via an anti-aliasing filter. This circuit is shown in Figure 9.2.2. These pairs of pins can be used as differential analog inputs with a voltage difference between 0-1V. The even numbers are connected to the positive pins of the pair and the odd numbers are connected to the negative pins (so A6 and A7 form an analog input pair with A6 being positive and A7 being negative). Note that though the pads for the capacitor are present, they are not loaded for these pins. Since the analog capable pins of the FPGA can also be used like normal digital FPGA pins, it is also possible to use these pins for Digital I/O.

The pins labeled V_P and V_N are connected to the VP_0 and VN_0 dedicated analog inputs of the FPGA. This pair of pins can also be used as a differential analog input with voltage between 0-1V, but they cannot be used as Digital I/O. The capacitor in the circuit shown in Figure 9.2.2 for this pair of pins is loaded on the Arty S7.

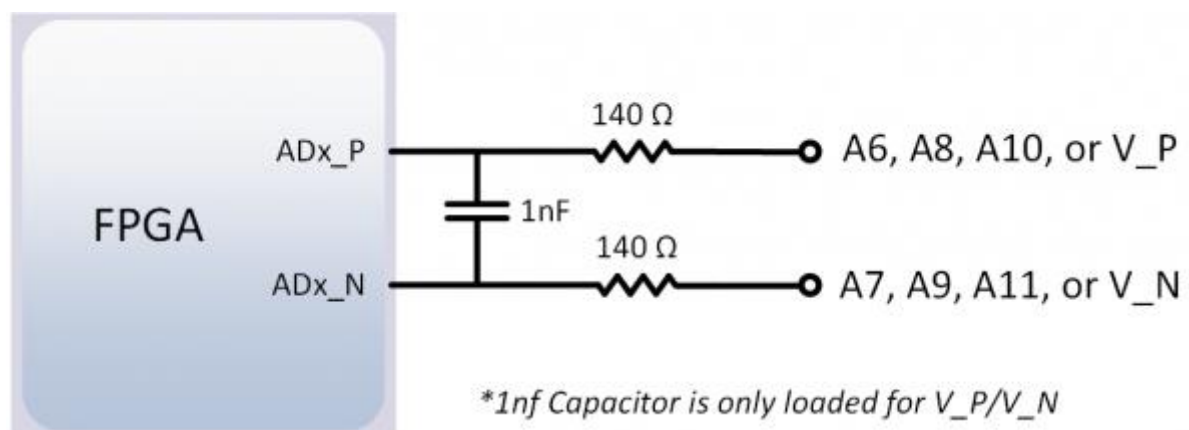

Figure 9.2.2. Differential Analog Inputs

The XADC core within the Spartan-7 is a dual channel 12-bit analog-to-digital converter capable of operating at 1 MSPS. Either channel can be driven by any of the analog inputs connected to the shield pins. The XADC core is controlled and accessed from a user design via the Dynamic Reconfiguration Port (DRP). The DRP also provides access to voltage monitors that are present on each of the FPGA's power rails, and a temperature sensor that is internal to the FPGA. For more information on using the XADC core, refer to the Xilinx document titled 7 Series FPGAs and Zynq-7000 All Programmable SoC XADC Dual 12-Bit 1 MSPS Analog-to-Digital Converter. A demo that uses the XADC core is available on the Arty S7 resource center.