



Direct starter, 3RM1, 500 V, 0.55 - 3 kW, 1.6 - 7 A, 24 V DC, spring-type terminals

<b>product brand name</b>	SIRIUS
<b>product category</b>	Motor starter
<b>product designation</b>	Direct-on-line starter
<b>design of the product</b>	with electronic overload protection
<b>product type designation</b>	3RM1
<b>General technical data</b>	
<b>trip class</b>	CLASS 10A
<b>equipment variant according to IEC 60947-4-2</b>	3
<b>product function</b>	Direct-on-line starter
• intrinsic device protection	Yes
• for power supply reverse polarity protection	No
<b>suitability for operation device connector 3ZY12</b>	Yes
<b>insulation voltage rated value</b>	500 V
<b>overvoltage category</b>	III
<b>surge voltage resistance rated value</b>	6 kV
<b>maximum permissible voltage for safe isolation</b>	
• between main and auxiliary circuit	500 V
• between control and auxiliary circuit	250 V
<b>shock resistance</b>	6g / 11 ms
<b>vibration resistance</b>	1 ... 6 Hz, 15 mm; 20 m/s <sup>2</sup> , 500 Hz
<b>operating frequency maximum</b>	1 1/s
<b>mechanical service life (switching cycles) typical</b>	30 000 000
<b>reference code according to IEC 81346-2</b>	Q
<b>Substance Prohibitance (Date)</b>	03/01/2017
<b>product function</b>	
• direct start	Yes
• reverse starting	No
<b>product function short circuit protection</b>	No
<b>Electromagnetic compatibility</b>	
<b>EMC emitted interference according to IEC 60947-1</b>	class A
<b>EMC immunity according to IEC 60947-1</b>	Class A
<b>conducted interference</b>	
• due to burst according to IEC 61000-4-4	3 kV / 5 kHz
• due to conductor-earth surge according to IEC 61000-4-5	2 kV
• due to conductor-conductor surge according to IEC 61000-4-5	1 kV
• due to high-frequency radiation according to IEC 61000-4-6	10 V
<b>field-based interference according to IEC 61000-4-3</b>	10 V/m

<b>electrostatic discharge according to IEC 61000-4-2</b>	4 kV contact discharge / 8 kV air discharge
<b>conducted HF interference emissions according to CISPR11</b>	Class B for the domestic, business and commercial environments
<b>field-bound HF interference emission according to CISPR11</b>	Class B for the domestic, business and commercial environments
<b>Safety related data</b>	
<b>protection class IP on the front according to IEC 60529</b>	IP20
<b>touch protection on the front according to IEC 60529</b>	finger-safe
<b>Main circuit</b>	
<b>number of poles for main current circuit</b>	3
<b>design of the switching contact</b>	Hybrid
<b>design of the switching contact as NO contact for signaling function</b>	OUT, electronic, 24 V DC, 15 mA
<b>adjustable current response value current of the current-dependent overload release</b>	1.6 ... 7 A
<b>minimum load [%]</b>	20 %; from set rated current
<b>type of the motor protection</b>	solid-state
<b>operating voltage rated value</b>	48 ... 500 V
<b>relative symmetrical tolerance of the operating voltage</b>	10 %
<b>operating frequency 1 rated value</b>	50 Hz
<b>operating frequency 2 rated value</b>	60 Hz
<b>relative symmetrical tolerance of the operating frequency</b>	10 %
<b>operational current</b>	
• at AC at 400 V rated value	7 A
• at AC-3 at 400 V rated value	7 A
• at AC-53a at 400 V at ambient temperature 40 °C rated value	7 A
<b>ampacity when starting maximum</b>	56 A
<b>operating power for 3-phase motors at 400 V at 50 Hz</b>	0.55 ... 3 kW
<b>derating temperature</b>	40 °C
<b>Inputs/ Outputs</b>	
<b>input voltage at digital input</b>	
• at DC rated value	24 V
• with signal <0> at DC	0 ... 5 V
• for signal <1> at DC	15 ... 30
<b>input current at digital input</b>	
• for signal <1> at DC	11 mA
• with signal <0> at DC	1 mA
<b>number of CO contacts for auxiliary contacts</b>	1
<b>operational current of auxiliary contacts at AC-15 at 230 V maximum</b>	3 A
<b>operational current of auxiliary contacts at DC-13 at 24 V maximum</b>	1 A
<b>Control circuit/ Control</b>	
<b>type of voltage of the control supply voltage</b>	DC
<b>control supply voltage at DC rated value</b>	19.2 ... 30 V
<b>relative negative tolerance of the control supply voltage at DC</b>	20 %
<b>relative positive tolerance of the control supply voltage at DC</b>	25 %
<b>control supply voltage 1 at DC rated value</b>	24 V
<b>operating range factor control supply voltage rated value at DC</b>	
• initial value	0.8
• full-scale value	1.25
<b>control current at DC</b>	
• in standby mode of operation	25 mA
• when switching on	150 mA
• during operation	70 mA
<b>duration of inrush current peak at 24 V</b>	85 ms

<b>power loss [W] in auxiliary and control circuit</b>	
<ul style="list-style-type: none"> <li>● in switching state OFF <ul style="list-style-type: none"> <li>— with bypass circuit</li> </ul> </li> </ul>	0.6 W
<ul style="list-style-type: none"> <li>● in switching state ON <ul style="list-style-type: none"> <li>— with bypass circuit</li> </ul> </li> </ul>	1.68 W
<b>Response times</b>	
<b>ON-delay time</b>	60 ... 90 ms
<b>OFF-delay time</b>	60 ... 90 ms
<b>Power Electronics</b>	
<b>operational current</b>	
<ul style="list-style-type: none"> <li>● at 40 °C rated value</li> </ul>	7 A
<ul style="list-style-type: none"> <li>● at 50 °C rated value</li> </ul>	6.1 A
<ul style="list-style-type: none"> <li>● at 55 °C rated value</li> </ul>	5.2 A
<ul style="list-style-type: none"> <li>● at 60 °C rated value</li> </ul>	4.6 A
<b>Installation/ mounting/ dimensions</b>	
<b>mounting position</b>	vertical, horizontal, standing (observe derating)
<b>fastening method</b>	screw and snap-on mounting onto 35 mm standard mounting rail
<b>height</b>	100 mm
<b>width</b>	22.5 mm
<b>depth</b>	141.6 mm
<b>required spacing</b>	
<ul style="list-style-type: none"> <li>● with side-by-side mounting <ul style="list-style-type: none"> <li>— forwards</li> <li>— backwards</li> <li>— upwards</li> <li>— downwards</li> <li>— at the side</li> </ul> </li> </ul>	0 mm
<ul style="list-style-type: none"> <li>— forwards</li> </ul>	0 mm
<ul style="list-style-type: none"> <li>— backwards</li> </ul>	50 mm
<ul style="list-style-type: none"> <li>— upwards</li> </ul>	50 mm
<ul style="list-style-type: none"> <li>— downwards</li> </ul>	0 mm
<ul style="list-style-type: none"> <li>— at the side</li> </ul>	0 mm
<ul style="list-style-type: none"> <li>● for grounded parts <ul style="list-style-type: none"> <li>— forwards</li> <li>— backwards</li> <li>— upwards</li> <li>— at the side</li> <li>— downwards</li> </ul> </li> </ul>	0 mm
<ul style="list-style-type: none"> <li>— forwards</li> </ul>	0 mm
<ul style="list-style-type: none"> <li>— backwards</li> </ul>	50 mm
<ul style="list-style-type: none"> <li>— upwards</li> </ul>	3.5 mm
<ul style="list-style-type: none"> <li>— at the side</li> </ul>	50 mm
<ul style="list-style-type: none"> <li>— downwards</li> </ul>	
<b>Ambient conditions</b>	
installation altitude at height above sea level maximum	4 000 m; For derating see manual
<b>ambient temperature</b>	
<ul style="list-style-type: none"> <li>● during operation</li> </ul>	-25 ... +60 °C
<ul style="list-style-type: none"> <li>● during storage</li> </ul>	-40 ... +70 °C
<ul style="list-style-type: none"> <li>● during transport</li> </ul>	-40 ... +70 °C
environmental category during operation according to IEC 60721	3K6 (no ice formation, only occasional condensation), 3C3 (no salt mist), 3S2 (sand must not get into the devices), 3M6
relative humidity during operation	10 ... 95 %
air pressure according to SN 31205	900 ... 1 060 hPa
<b>Communication/ Protocol</b>	
<b>protocol is supported</b>	
<ul style="list-style-type: none"> <li>● PROFINET IO protocol</li> </ul>	No
<ul style="list-style-type: none"> <li>● PROFI-safe protocol</li> </ul>	No
<b>product function bus communication</b>	No
protocol is supported AS-Interface protocol	No
<b>Connections/ Terminals</b>	
<b>type of electrical connection</b>	spring-loaded terminals (push-in) for main circuit, spring-loaded terminals (push-in) for control circuit
<ul style="list-style-type: none"> <li>● for main current circuit</li> </ul>	spring-loaded terminals (push-in)
<ul style="list-style-type: none"> <li>● for auxiliary and control circuit</li> </ul>	spring-loaded terminals (push-in)
<b>wire length for motor unshielded maximum</b>	100 m
<b>type of connectable conductor cross-sections</b>	
<ul style="list-style-type: none"> <li>● for main contacts <ul style="list-style-type: none"> <li>— solid</li> <li>— finely stranded with core end processing</li> <li>— finely stranded without core end processing</li> </ul> </li> </ul>	1x (0.5 ... 4 mm <sup>2</sup> )
<ul style="list-style-type: none"> <li>— solid</li> </ul>	1x (0.5 ... 2.5 mm <sup>2</sup> )
<ul style="list-style-type: none"> <li>— finely stranded with core end processing</li> </ul>	1x (0.5 ... 4 mm <sup>2</sup> )
<ul style="list-style-type: none"> <li>— finely stranded without core end processing</li> </ul>	

<ul style="list-style-type: none"> <li>at AWG cables for main contacts</li> </ul>	1x (20 ... 12)
<b>connectable conductor cross-section for main contacts</b> <ul style="list-style-type: none"> <li>solid or stranded</li> <li>finely stranded with core end processing</li> <li>finely stranded without core end processing</li> </ul>	0.5 ... 4 mm <sup>2</sup> 0.5 ... 2.5 mm <sup>2</sup> 0.5 ... 4 mm <sup>2</sup>
<b>connectable conductor cross-section for auxiliary contacts</b> <ul style="list-style-type: none"> <li>solid or stranded</li> <li>finely stranded with core end processing</li> <li>finely stranded without core end processing</li> </ul>	0.5 ... 1.5 mm <sup>2</sup> 0.5 ... 1 mm <sup>2</sup> 0.5 ... 1.5 mm <sup>2</sup>
<b>type of connectable conductor cross-sections</b> <ul style="list-style-type: none"> <li>for auxiliary contacts               <ul style="list-style-type: none"> <li>— solid</li> <li>— finely stranded with core end processing</li> <li>— finely stranded without core end processing</li> </ul> </li> <li>at AWG cables for auxiliary contacts</li> </ul>	1x (0.5 ... 1.5 mm <sup>2</sup> ), 2x (0.5 ... 1.5 mm <sup>2</sup> ) 1x (0,5 ... 1,0 mm <sup>2</sup> ), 2x (0,5 ... 1,0 mm <sup>2</sup> ) 1x (0.5 ... 1.5 mm <sup>2</sup> ), 2x (0.5 ... 1.5 mm <sup>2</sup> ) 1x (20 ... 16), 2x (20 ... 16)
<b>AWG number as coded connectable conductor cross section</b> <ul style="list-style-type: none"> <li>for main contacts</li> <li>for auxiliary contacts</li> </ul>	20 ... 12 20 ... 16

### UL/CSA ratings

<b>yielded mechanical performance [hp]</b> <ul style="list-style-type: none"> <li>for single-phase AC motor               <ul style="list-style-type: none"> <li>— at 110/120 V rated value</li> <li>— at 230 V rated value</li> </ul> </li> <li>for 3-phase AC motor               <ul style="list-style-type: none"> <li>— at 200/208 V rated value</li> <li>— at 220/230 V rated value</li> <li>— at 460/480 V rated value</li> </ul> </li> </ul>	0.25 hp 0.5 hp 1 hp 1.5 hp 3 hp
<b>operating voltage at AC</b> <ul style="list-style-type: none"> <li>according to UL rated value</li> <li>according to CSA rated value</li> </ul>	480 V 400 V

### Certificates/ approvals

General Product Approval	EMC
--------------------------	-----



[Confirmation](#)



Declaration of Conformity	Test Certificates	other	Railway
---------------------------	-------------------	-------	---------



[Type Test Certificates/Test Report](#)

[Confirmation](#)

[Special Test Certificate](#)

### Further information

Information- and Downloadcenter (Catalogs, Brochures,...)

<https://www.siemens.com/ic10>

Industry Mall (Online ordering system)

<https://mall.industry.siemens.com/mall/en/en/Catalog/product?mlfb=3RM1007-2AA04>

Cax online generator

<http://support.automation.siemens.com/WW/CAXorder/default.aspx?lang=en&mlfb=3RM1007-2AA04>

Service&Support (Manuals, Certificates, Characteristics, FAQs,...)

<https://support.industry.siemens.com/cs/ww/en/ps/3RM1007-2AA04>

Image database (product images, 2D dimension drawings, 3D models, device circuit diagrams, EPLAN macros, ...)

[http://www.automation.siemens.com/bilddb/cax\\_de.aspx?mlfb=3RM1007-2AA04&lang=en](http://www.automation.siemens.com/bilddb/cax_de.aspx?mlfb=3RM1007-2AA04&lang=en)

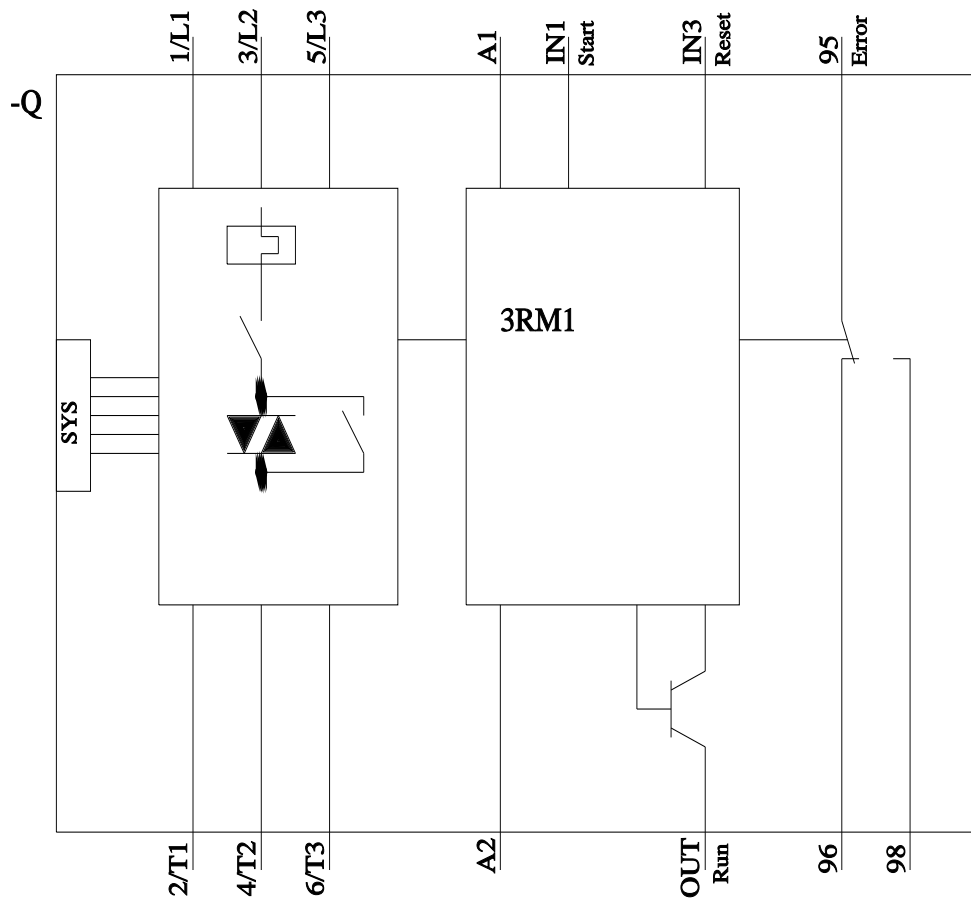
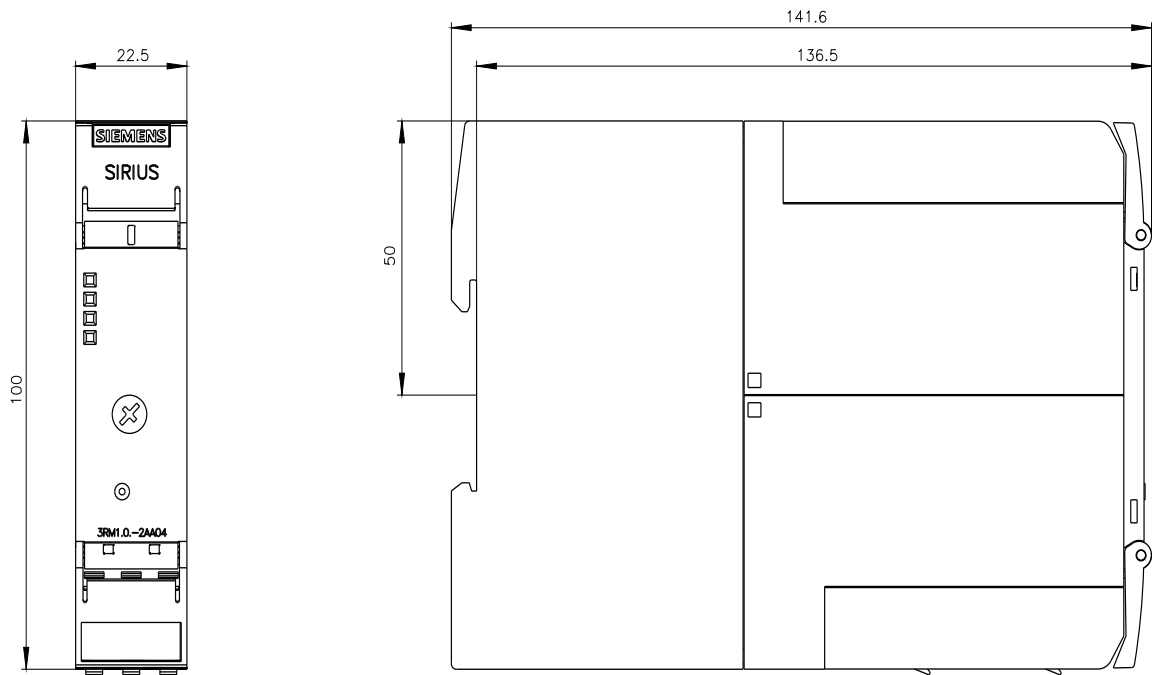

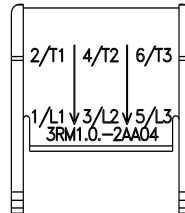
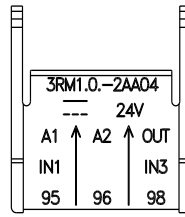
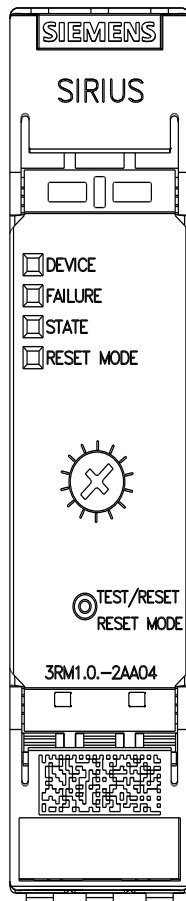

last modified:

11/3/2021 