

THIS DRAWING IS UNPUBLISHED. RELEASED FOR PUBLICATION
 © COPYRIGHT - By - ALL RIGHTS RESERVED.

REVISIONS					
P	LTR	DESCRIPTION	DATE	DWN	APVD
	G	REV PER 0G3A-0031-04	29JAN04	-	JR
	G1	REVISED PER ECO-17-003799	20MAR2017	BDA	DR

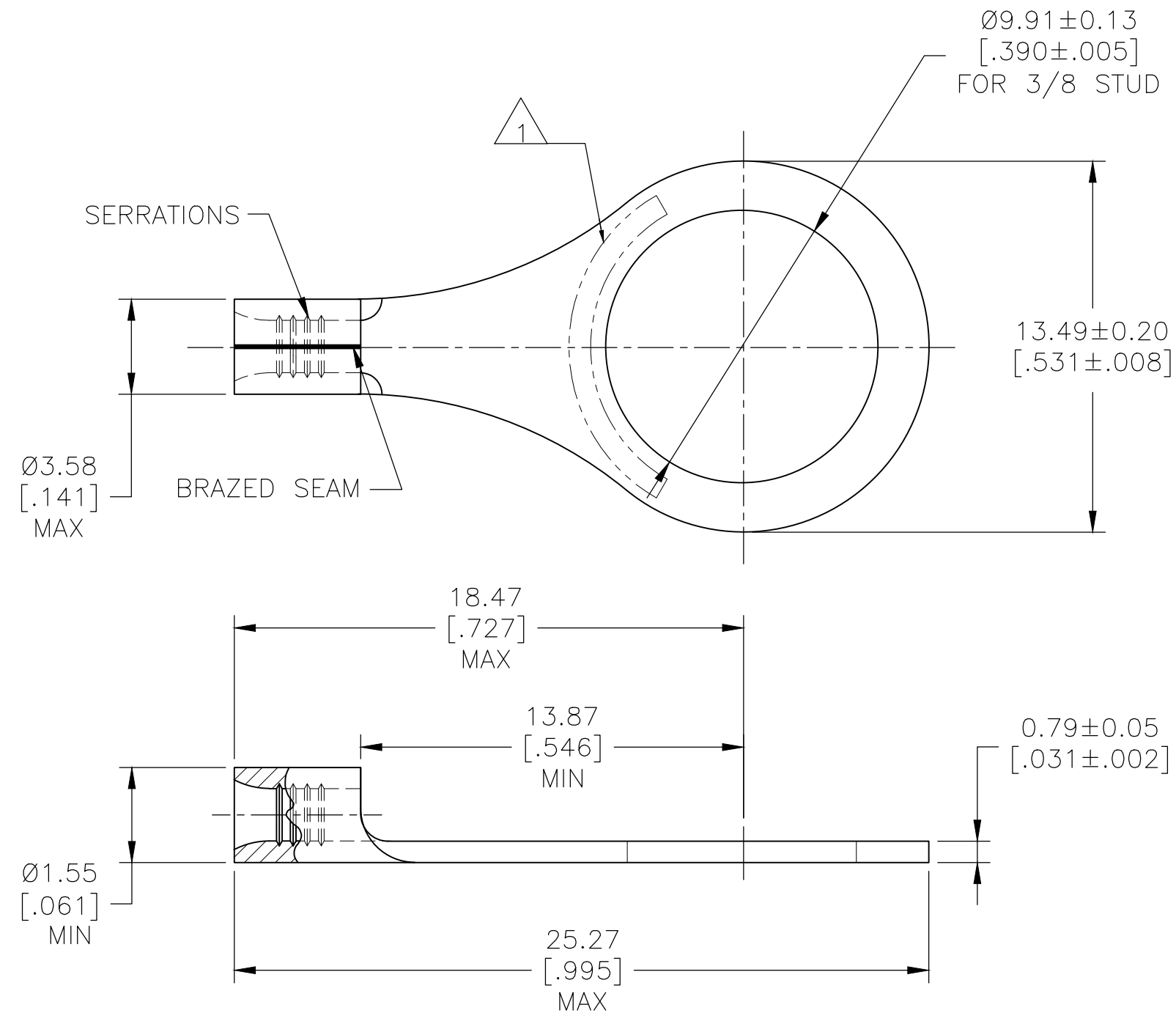

AMP WIRE RANGE	E13288 Listed
22-16 AWG SOLID OR STRANDED	22-16 AWG SOLID OR STRANDED
LR7189 Certified	MILITARY P/N AND CLASS
22-16 AWG SOLID OR STRANDED	M7928/7-6 CLASS 2 P/N 34115 & 2-34115-2 ONLY

- 1 STAMP AMP 22-18* APPROX AS SHOWN
22-16 TERMINALS ARE STAMPED 22-18 IN
ACCORDANCE WITH MILITARY SPECIFICATION
SAE AS7928 COMMERCIAL WIRE RANGE IS 22-16
- 2 TIN PLATE 0.00254[.000100] MIN THK PER ASTM B-545
- 3 NICKEL PLATE 0.00762[.000300] MIN THK PER
SAE AMS QQ-N-290
- 4 P/N 34115-1 IS NOT UL OR CSA APPROVED

FINISH	QTY.	PACKAGE TYPE	PART NUMBER
3	1000	LOOSE PIECE	4 34115-1
2	100	LOOSE PIECE, BOX	8-34115-1
2	5000	ON TAPE	2-34115-2
2	1000	LOOSE PIECE	34115

AMP INCORPORATED
CUSTOMER SERVICE SYSTEMS

FOR ADDITIONAL PRODUCT INFORMATION OR COPIES OF DRAWINGS AND TECHNICAL DOCUMENTS	PRODUCT INFORMATION CENTER 1-800-522-6752
FOR APPLICATION TOOLING INFORMATION	TOOLING ASSISTANCE CENTER 1-800-722-1111
FOR ORDER ENTRY	1-800-526-5142

MAX RECOMMENDED OPERATING TEMPERATURE: 170°C [338°F] MAX
VOLTAGE RATING: NOT APPLICABLE
WIRE CROSS SECTIONAL AREA RANGE, 0.26-1.65mm ² [509-3,260] CIR MILS SOLID OR STRANDED

THIS DRAWING IS A CONTROLLED DOCUMENT.

DIMENSIONS: mm [INCHES]	TOLERANCES UNLESS OTHERWISE SPECIFIED:
	0 PLC ± -
	1 PLC ± -
	2 PLC ± -
	3 PLC ± -
	4 PLC ± -
	ANGLES ± -
MATERIAL COPPER PER ASTM B-152 ANNEALED	FINISH SEE TABLE

DWN TA BRINKMAN 3-10-93	NAME TERMINAL, RING TONGUE, SOLISTRAND 22-16 AWG
CHK DA PATTERSON 3-10-93	
APVD DE MILLER 3-10-93	
PRODUCT SPEC	
APPLICATION SPEC	SIZE A3
WEIGHT -	CAGE CODE 00779
CUSTOMER DRAWING	DRAWING NO C-34115



RESTRICTED TO	SCALE 8:1	SHEET 1 OF 1	REV G1
---------------	--------------	-----------------	-----------