

THIS DRAWING IS UNPUBLISHED. **XXXXXXXXXXXXX** DATE: -
 © COPYRIGHT - 97 By Tyco Electronics Nederland B.V. ALL RIGHTS RESERVED.

LOC	DIST	REVISIONS			
H	-	LTR	DESCRIPTION	DATE	APVD
		A	ECN 260/98	02/07/98	MG
		D	ECN 0080-00	18/04/00	MG
		E	EH01-0232-04	16 FEB 04	EL

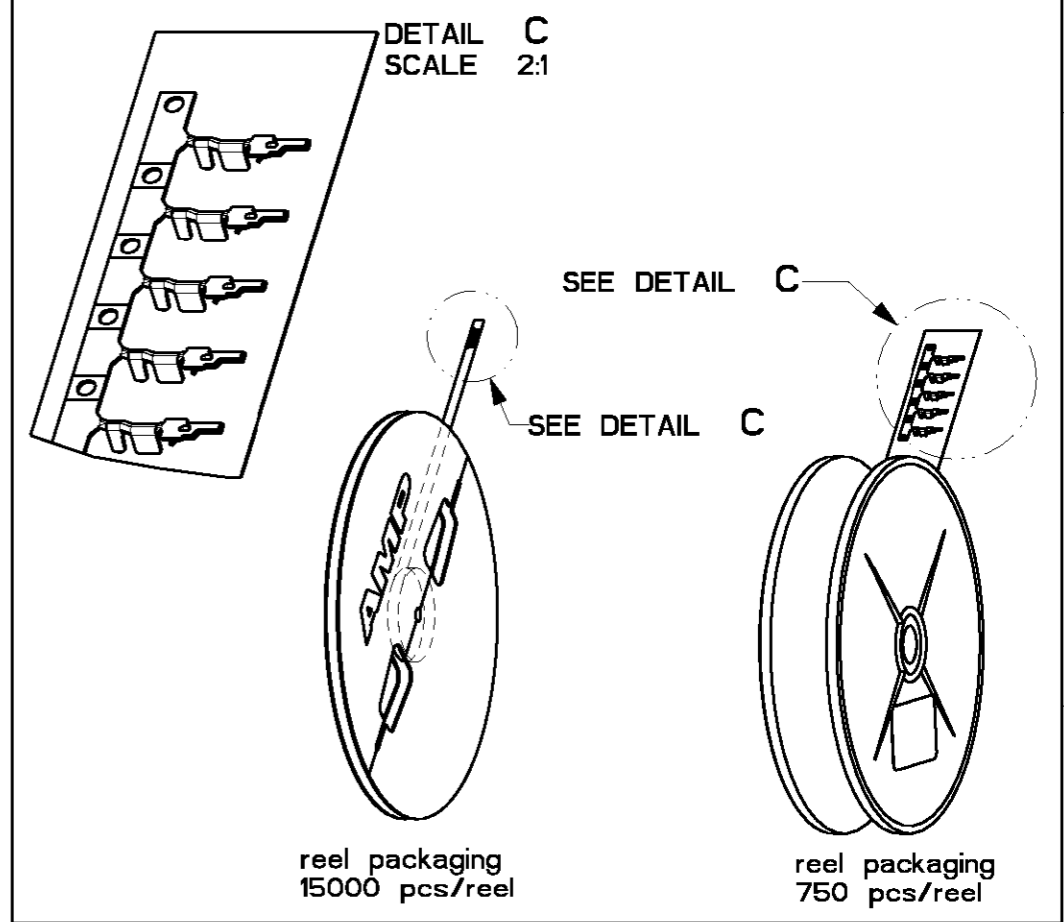

- NOTES:**
1. WIRE RANGE 24-28 AWG
 2. INSULATION RANGE ϕ .030- .040 (0,76-1,00 mm)
 3. FOR APPLICATOR USE ONLY
 4. FOR HANDTOOL USE ONLY
 5. FOR APPLICABLE CONNECTOR HOUSINGS SEE C-338095.

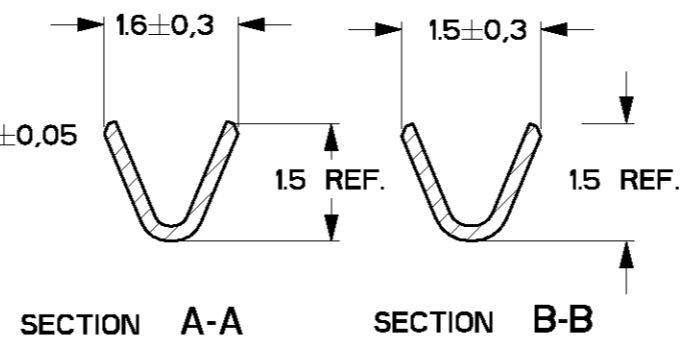
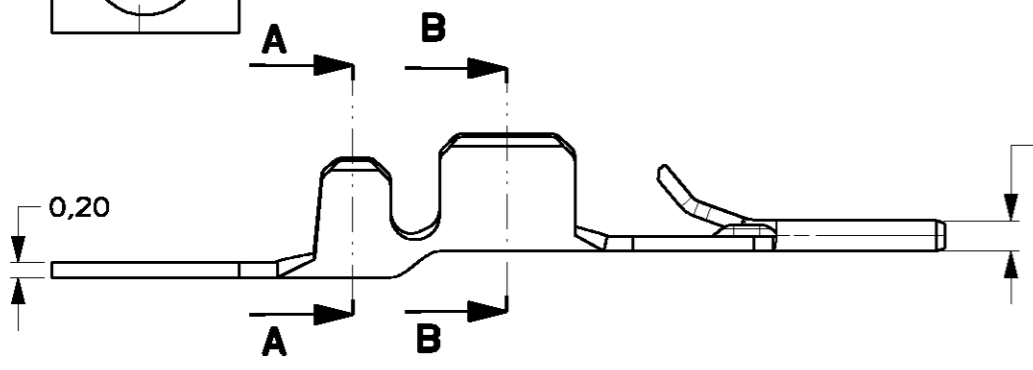
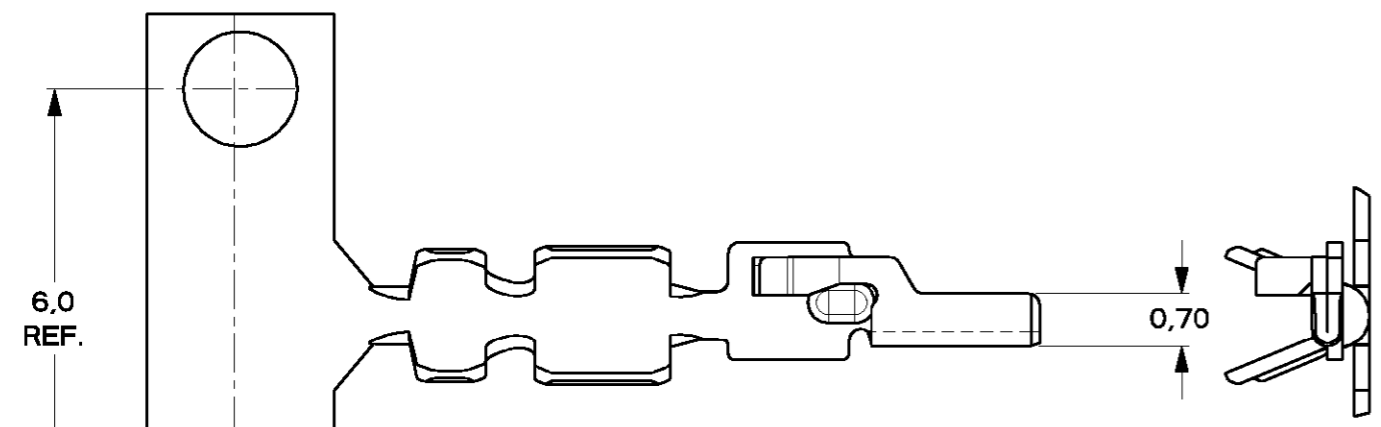
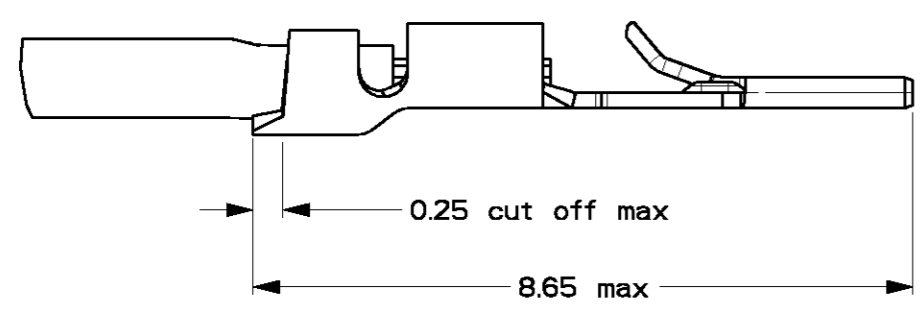
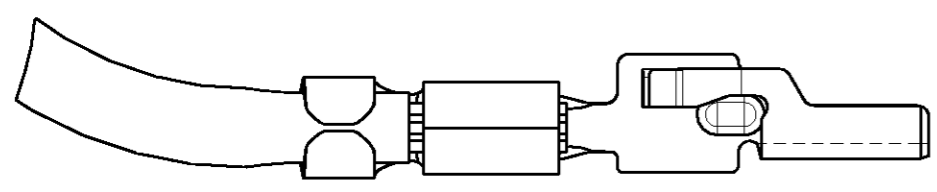

4	750	Pre-Tin	COSI-contact	Phosphorbronze	1-0338096-1
3	15000	Pre-Tin	COSI-Contact	Phosphorbronze	0-0338096-1
	Pcs/reel	Finish	Description	Material	Part number

THIS DRAWING IS A CONTROLLED DOCUMENT FOR Tyco Electronics Nederland B.V. IT IS SUBJECT TO CHANGE AND THE CONTROLLING ENGINEERING ORGANIZATION SHOULD BE CONTACTED FOR THE LATEST REVISION.

DIMENSIONS:	TOLERANCES UNLESS OTHERWISE SPECIFIED:
mm	
	0 PLC ± 0.2
	1 PLC ± 0.1
	2 PLC ± 0.05
	3 PLC ± 0.01
	4 PLC ± -
	ANGLES ± 0.2°

MATERIAL	FINISH
Brass	Pre-tinplated

DWN	M.v.Amelsfoort	AMP Tyco Electronics Nederland B.V. *S-HERTOGENBOSCH, THE NETHERLANDS	
CHK	H.v.Delft		
APVD	-		
PRODUCT SPEC	108-19052		
APPLICATION SPEC	114-19051	NAME	Micro-MaTch COSI-CONTACT
WEIGHT	-	SIZE	A3
CUSTOMER DRAWING		CAGE CODE	00779
		DRAWING NO	C- 338096
		SCALE	10:1
		SHEET	1 OF 1
		REV	E