



SENSECAP

# pH Sensor (S-pH-01)

## User Guide

Version: V2.0

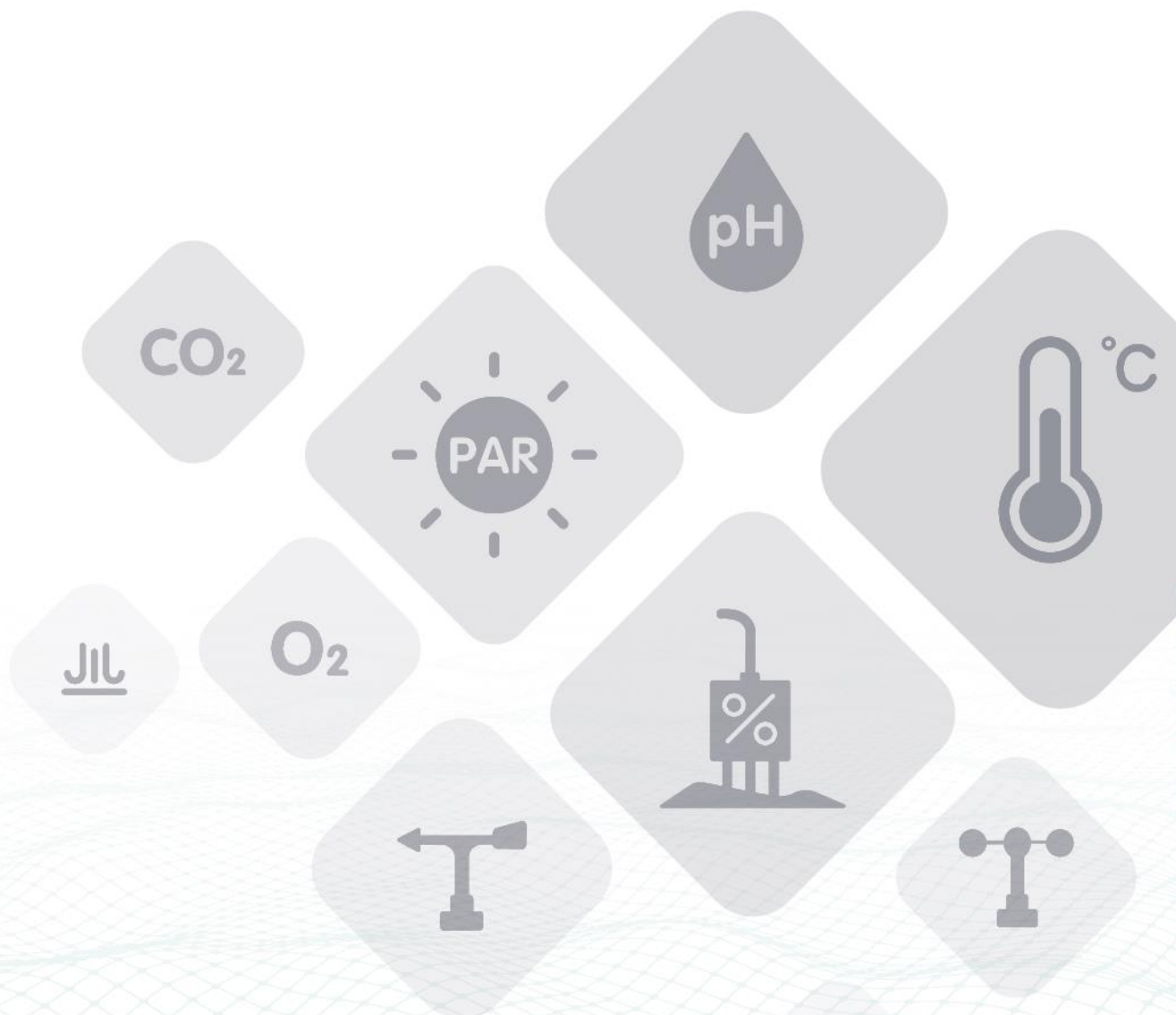

## Content

1. Introduction .....	3
2. Wiring diagrams .....	4
3. Dimension .....	5
4. Installation Maintenance and Calibration.....	6
5. Output Signal Conversion .....	7
6. RS485 Modbus Protocol .....	8
6.1 Modbus Protocol .....	8
6.2 Modbus Register .....	9
6.3 Modbus Register Detail Description .....	11
6.4 Modbus Function Code .....	14
6.4.1 Function Code 3 Protocol Example .....	14
6.4.2 Function Code 4 Protocol Example .....	15
6.4.3 Function Code 6 Protocol Example .....	16
6.4.4 Function Code 16 Protocol Example .....	17
7. Software Configuration Utility .....	19

# 1. Introduction

S-PH-01 transmitter measures the PH of solution or semi-solid substrate. The output signal can be RS485 and Analog Voltage. The sensor is applicable for industrial, water processing, sewerage system, irrigation, smart agriculture etc.

- Can be used for PH measurement
- Output Interface with RS485, Voltage
- High impedance and isolated electrode input
- High accuracy with excellent stability
- Reverse power protection and Built-in TVS/ESD protection

Specifications		
<b>Output Interface</b>	Analog Voltage 0-2V (Output resistance ~0ohm)	RS485 Modbus-RTU
<b>Power Supply</b>	3.9-30V/DC	3.9-30V/DC
<b>Power Consumption</b>	35mA@24V DC	35mA@24V DC
<b>Start-up time</b>	< 2 seconds	
<b>PH Measurement</b>	High impedance and isolated input; Range: 0-14PH, Resolution: 0.01PH, Accuracy: +/-0.1PH; Can be used for solution or semi-solid substrate	
<b>Temperature Measurement (Option)</b>	Range: -40~80°C, Resolution: 0.1°C, Accuracy: +/-0.5°C	
<b>IP Ratings</b>	Electrode: IP68; Transmitter: IP65	
<b>Operating Temperature</b>	-40~85°C	
<b>Installation</b>	Electrode: 3/4"NPT screw threads; Transmitter: Mounting hole	
<b>Cable Length</b>	Power and Signal Cable:2 meters or Customize; Electrode Cable: 5 meters	
<b>Dimension</b>	Electrode: Width*Diameter 160*30mm; 3/4"NPT screw threads Transmitter: 140mm*65mm*50mm	

## 2. Wiring diagrams

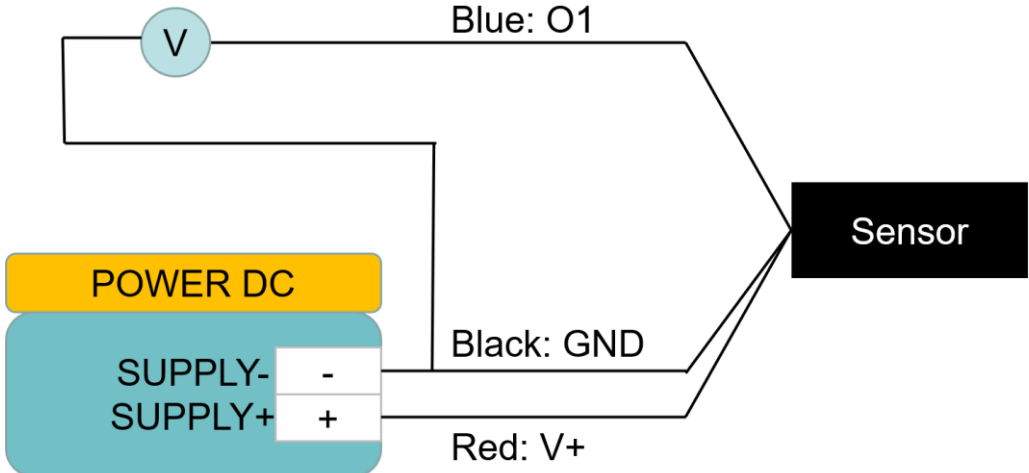
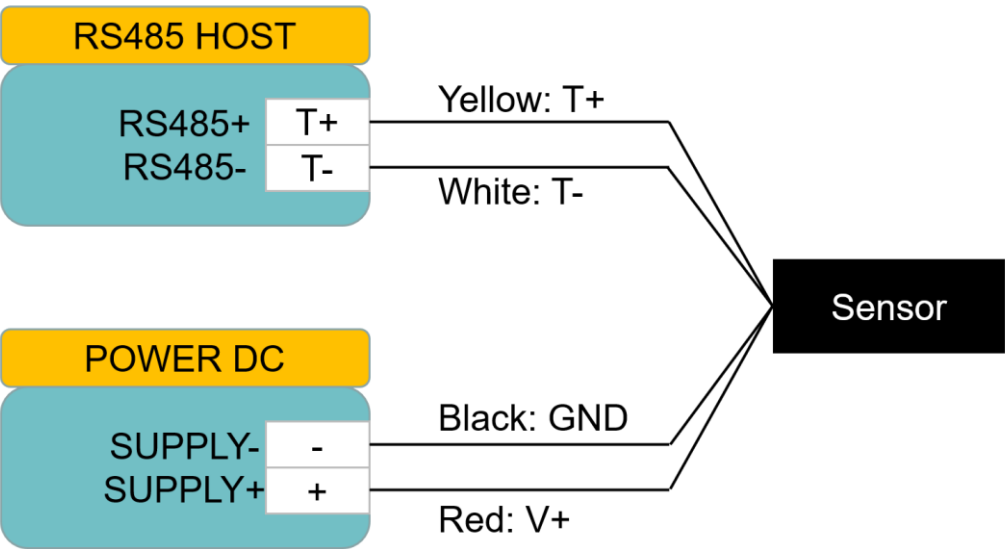
Type	Wiring diagram
<b>Analog Voltage Output</b>	<p data-bbox="363 387 654 499">                     Red (V+): Power Supply +                      Black (G): Power Supply -                      Blue (O1): Analog Output                 </p> 
<b>RS485 Modbus</b>	<p data-bbox="363 1050 654 1207">                     Red (V+): Power Supply +                      Black (G): Power Supply -                      Yellow (T+): RS485+/A/T+                      White (T-): RS485-/B/T-                 </p> 

### 3. Dimension

#### Electrode Dimension



#### Transmitter Dimension

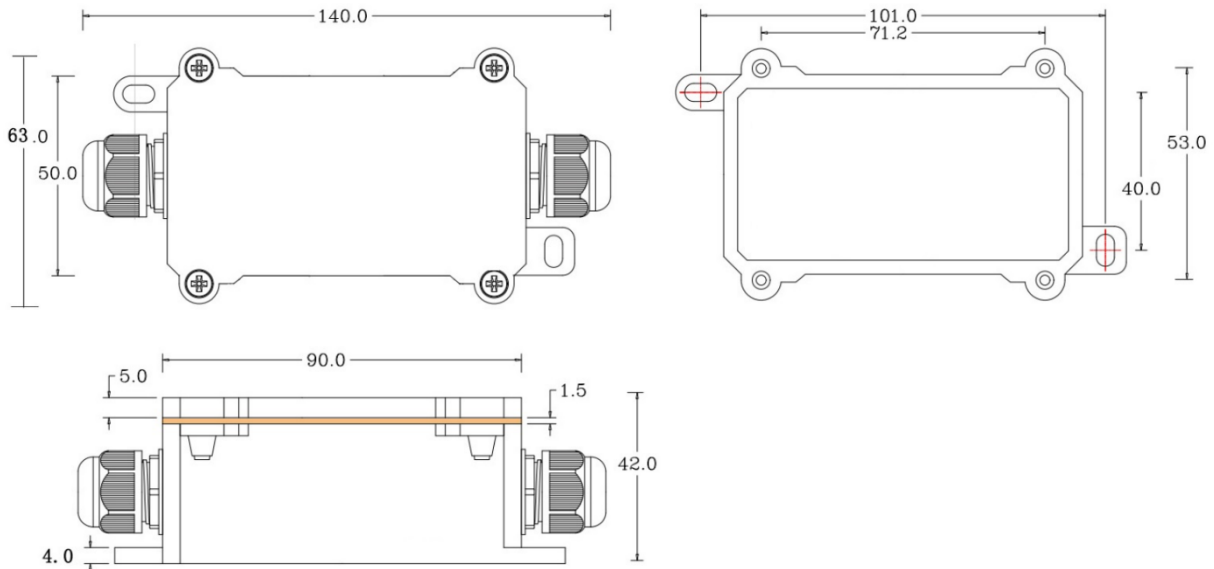

## 4. Installation Maintenance and Calibration

### 4.1 Installation

Installation locations of Electrodes will vary depending on the system design. The key is to monitor a good representative sample of the whole solution directly after introduction of chlorine. The installation location must allow for complete contact of the scrubber liquid with the probes. Some example installation locations for Electrodes include the following:

- Outlet of packed tower
- Outlet of recycle pump
- Pump bypass line
- Heat Exchanger bypass line

### 4.2 Maintenance

Under normal conditions, electrodes can last anywhere from several months to several years depending on the type of operation, rate of production, strength of product, and quality of the raw materials used in the process. Because each application is different, there is no average life expectancy.

Because the pH responsive glass bulb or flat surface is relatively thin, care should be taken so that the bulb does not become scratched or broken. It is also important that ORP measuring surfaces are not scratched or gouged. The suggestions in this sheet are intended to help avoid these problems. Coating of an electrode's measuring surface can lead to erroneous readings including shortened span and slow response times. The type of coating determines the type of cleaning technique. Soft Coatings can be removed by vigorous stirring, by use of a squirt bottle or, very carefully, by gently wiping with a soft, clean non-abrasive paper or cloth. Hard Coatings should be chemically removed. The chemical used to remove the coating should be the least harsh chemical that dissolves the coating in 1 or 2 minutes and does not attack the electrode's materials of construction. For example, a calcium carbonate coating might be removed with 5% HCl (muriatic acid). Oily or Organic Coatings are best removed with detergents or an appropriate solvent that does not attack the electrode's materials of construction. For example, isopropyl alcohol might be used but acetone should be avoided if the electrode's body is made of CPVC.

## 5. Output Signal Conversion

PH output conversion

Output Interface	Parameters Range	Conversion Formula
<b>Analog Voltage Output 0-2V</b>	PH range: 0-14PH	$PH = 7.00 * VOLTAGE$ . When $VOLTAGE = 1.0V$ , then $PH = 7.00 * 1.00 = 7$ .
<b>RS485 Modbus-RTU</b>	PH range: 0-14PH	$PH = (REGISTER\ VALUE) / 100$ . When $REGISTER\ VALUE = 7000$ , then $PH = 7000 / 100 = 7.00$ .
	Temperature range: -40-80°C	$TEMPERATURE = (REGISTER\ VALUE) / 100$ . When $REGISTER\ VALUE = 2013$ , then $TEMPERATURE = 2013 / 100 = 20.13^{\circ}C$ .

NOTE: The unit of VOLTAGE is (V)

## 6. RS485 Modbus Protocol

### 6.1 Modbus Protocol

Modbus Protocol is widely used to establish master-slave communication between intelligent devices or sensors. A MODBUS message sent from a master to a slave contains the address of the slave, the function code (e.g. 'read register' or 'write register'), the data, and a check sum (LRC or CRC).

The sensor is RS485 interface with Modbus protocol. The default serial communication settings is slave address 1, modbus rtu, 9600bps, 8 databits and 1 stop bit. All communication settings can be changed with modbus command, and take effective after re-power up the sensor.

Following modbus function code are supported by sensor.

Modbus Function Code 0x03 : used for reading holding register.

Modbus Function Code 0x04 : used for reading input register.

Modbus Function Code 0x06 : used for writing single holding register.

Modbus Function Code 0x10: used for writing multiple holding register.



## 6.2 Modbus Register

Parameters	Register Addr. (HEX/DEC)	Data Type	Modbus Function Code(DEC)	Range and Comments	Default Value
TEMPRATURE	0x0000 /0	INT16 RO	3/4	-4000-8000 for -40.00~80.00°C.	N/A
PH PHVALUE	0x0001 /1	UINT16 RO	3/4	0-1400 for 0.00-14.00	N/A
TEMPCOMPENSATEE N	0x0020 /32	UINT16 R/W	3/6/16	0: External Temperature sensor 1: Disabled 2:On board temperature sensor	1
PHCALIBRAWAD0 PH calibration point for PH=4.01	0x0030 /48	UINT16 R/W	3/6/16	-2000~2000 for -2000~2000; Write 0xFFFF to calibrate.	N/A
PHCALIBRAWAD1 PH calibration point for PH=7.00	0x0031 /49	UINT16 R/W	3/6/16	-2000~2000 for -2000~2000; Write 0xFFFF to calibrate.	N/A
PHCALIBRAWAD2 PH calibration point for PH=10.01	0x0032 /50	UINT16 R/W	3/6/16	-2000~2000 for -2000~2000; Write 0xFFFF to calibrate.	N/A
SLAVEADDRESS	0x0200 /512	UINT16 R/W	3/6/16	0-255	1 or 12
BAUDRATE	0x0201 /513	UINT16 R/W	3/6/16	0-6 0:1200bps 1:2400bps 2:4800bps 3:9600bps 4:19200bps 5:38400bps	3:9600bps
PROTOCOL	0x0202 /514	UINT16 R/W	3/6/16	0-1 0:Modbus RTU	0:Modbus RTU
PARITY	0x0203 /515	UINT16 R/W	3/6/16	0-2 0:None 1:Even 2:Odd	0:None Parity
DATABITS	0x0204 /516	UINT16	3/6/16	1	1:8 databits

		R/W		1:8 databits	
STOPBITS	0x0205 /517	UINT16 R/W	3/6/16	0-1 0:1 stopbit 1:2 stopbits	0:1 stopbit
RESPONSEDELAY	0x0206 /518	UINT16 R/W	3/6/16	0-255 for 0-2550 milliseconds	0
ACTIVEOUTPUTINTER VAL	0x0207 /519	UINT16 R/W	3/6/16	0-255 for 0-255 seconds.	0

NOTE: UINT16:16 bit unsigned integer, INT16:16bit signed integer

NOTE: RO: Register is Read Only, R/W: Register is Read/Write

NOTE: HEX is Hexadecimal (data with 0x/0X prefix), DEC is Decimal

## 6.3 Modbus Register Detail Description

TEMPERATURE		
Data Range	-4000-8000 For -40.00~80.00°C	Default: N/A
Power Down Save	N/A	

Note:Temperature value (Binary complement).

Example:When REGISTER = 0x0702 (HEX format), then VALUE=(0x07\*256+0x02)/100=17.94°C.When REGISTER=FF05H (HEX format),then VALUE=((0xFF\*256+0x05)-0xFFFF-0x01)/100 =(0xFF05-0xFFFF-0x01)/100=-2.51°C.

PH VALUE		
Data Range	0-1400 for 0-14.00PH	Default: N/A
Power Down Save	N/A	

Note: PH value

Example:When REGISTER = 0x02BC (HEX format), then VALUE=(0x02\*256+0xBC)/100=7.00PH

TEMPCOMPENSATEEN		
Data Range	0: External Temperature sensor 1: Disabled 2:On board temperature sensor	Default: 1
Power Down Save	YES	

Note: Temperature compensation

PHCALIBRAWAD0		
Data Range	-2000~2000	Default: N/A
Power Down Save	YES	

Note:PH calibration AD value for PH=4.01; Immerse the electrode into PH=4.01 solution and wait until the reading value being stable,then write 0xFFFF to this register to calibrate.

PHCALIBRAWAD1		
Data Range	-2000~2000	Default: N/A
Power Down Save	YES	

Note:PH calibration AD value for PH=7.00; Immerse the electrode into PH=7.00 solution and wait until the reading value being stable,then write 0xFFFF to this register to calibrate.

PHCALIBRAWAD2		
---------------	--	--

Data Range	-2000~2000	Default: N/A
Power Down Save	YES	

Note:PH calibration AD value for PH=10.01; Immerse the electrode into PH=10.01 solution and wait until the reading value being stable,then write 0xFFFF to this register to calibrate.

<b>SLAVEADDRESS --- Modbus Slave Address</b>		
Data Range	0-255	Default: 1 or 12
Power Down Save	YES	

Note: Please re-power on the sensor to take effective after set.

<b>BAUDRATE --- Serial Comm Baudrate</b>		
Data Range	<b>0-5</b> <b>0:</b> 1200bps <b>1:</b> 2400bps <b>2:</b> 4800bps <b>3:</b> 9600bps <b>4:</b> 19200bps <b>5:</b> 38400bps	Default: 3
Power Down Save	YES	

Note: Please re-power on the sensor to take effective after set.

<b>PROTOCOL --- Serial Comm Protocol</b>		
Data Range	0 0:Modbus RTU	Default: 0
Power Down Save	YES	

Note: Please re-power on the sensor to take effective after set.

<b>PARITY --- Serial Comm Parity</b>		
Data Range	0-2 0:NONE 1:EVEN 2:ODD	Default: 0
Power Down Save	YES	

Note: Please re-power on the sensor to take effective after set.

<b>DATABITS --- Serial Comm Databits</b>		
Data Range	1 1:8 databits	Default: 1
Power Down Save	YES	

Note: Please re-power on the sensor to take effective after set.

<b>STOPBITS --- Serial Comm Stopbits</b>		
Data Range	0-1 0:1 stopbit 1:2 stopbits	Default: 0
Power Down Save	YES	

Note: Please re-power on the sensor to take effective after set.

<b>RESPONSEDELAY --- Serial Comm Response Delay</b>		
Data Range	0-255 for 0-2550 milliseconds, 0 for disabled	Default: 0
Power Down Save	YES	

Note: Please re-power on the sensor to take effective after set.

Note: Sensor will delay a period before response to master request command.

Example: When set to 5 and receive a request from master device, then sensor will delay  $5 * 10\text{ms} = 50\text{ms}$ , then response to master.

<b>ACTIVEOUTPUTINTERVAL --- Serial Comm Active Output Interval time</b>		
Data Range	0-255 for 0-255 seconds, 0 for disabled	Default: 0
Power Down Save	YES	

Note: Please re-power on the sensor to take effective after set.

Note: Sensor will output the data actively without any master request command.

Note: Only ONE sensor should be on RS485 network, or there will be data collision and corrupt the data on line.

Note: Use key button to restore the serial comm parameters factory value to exit the active output mode.

Example: When set to 5 then sensor will output the data every 5 seconds without any master request command.

## 6.4 Modbus Function Code

For description below, data started with 0X/0x means that it's in HEX format.

### 6.4.1 Function Code 3 Protocol Example

**Master Request:AA 03 RRRR NNNN CCCC**

AA	1 byte	Slave Address,0-255
0x03	1 byte	Function Code 3
RRRR	2 byte	Starting Register Addr
NNNN	2 byte	Quantity of Register to read
CCCC	2 byte	CRC CHECKSUM

**Slave Response:AA 03 MM VV0 VV1 VV2 VV3... CCCC**

AA	1 byte	Slave Address,0-255
0x03	1 byte	Function Code 3
MM	1 byte	Register Data Byte Count
VV0,VV1	2 byte	Register Value (High8bits first)
VV2,VV3	2 byte	Register Value (High8bits first)
...	...	Register Value (High8bits first)
CCCC	2 byte	CRC CHECKSUM

**Example:Read register 0x0200-0x0201,that is slave address and baudrate.**

**Master Request:01 03 0200 0002 C5B3**

Slave Addr.	1 byte	0x01
Function Code	1 byte	0x03
Starting Register Addr.	2 byte	0x0200
Quantity of Register to read	2 byte	0x0002
Checksum	2 byte	0xC5B3

**Slave Response:01 03 04 00 01 00 03 EB F2**

Slave Addr.	1 byte	0x01
-------------	--------	------

Function Code	1 byte	0x03
Register Data Byte Count	1 byte	0x04
Register Value: Address	2 byte	0x00(HIGH 8 Bits) 0x01(LOW8 Bits)
Register Value: Baudrate	2 byte	0x00(HIGH 8 Bits) 0x03(LOW8 Bits)
Checksum	2 byte	0xEBF2

### 6.4.2 Function Code 4 Protocol Example

#### Master Request:AA 04 RRRR NNNN CCCC

AA	1 byte	Slave Address,0-255
0x04	1 byte	Function Code 4
RRRR	2 byte	Starting Register Addr
NNNN	2 byte	Quantity of Register to read
CCCC	2 byte	CRC CHECKSUM

#### Slave Response:AA 04 MM VV0 VV1 VV2 VV3... CCCC

AA	1 byte	Slave Address,0-255
0x04	1 byte	Function Code 4
MM	1 byte	Register Data Byte Count
VV0,VV1	2 byte	Register Value (High8bits first)
VV2,VV3	2 byte	Register Value (High8bits first)
...	...	Register Value (High8bits first)
CCCC	2 byte	CRC CHECKSUM

**Example:Read register 0x0000-0x0002,that is temperature, PH value.**

#### Master Request: 01 04 0000 0002 71CB

Slave Addr.	1 byte	0x01
Function Code	1 byte	0x04
Starting Register Addr.	2 byte	0x0000

Quantity of Register to read	2 byte	0x0002
Checksum	2 byte	0x71CB

**Slave Response: 01 04 04 08C3 029E 8910**

Slave Addr.	1 byte	0x01
Function Code	1 byte	0x04
Register Data Byte Count	1 byte	0x04
Register Value: Temperature	2 byte	0x08(HIGH 8 Bits)
		0xC3(LOW8 Bits)
Register Value: PH	2 byte	0x02(HIGH 8 Bits)
		0x9E(LOW8 Bits)
Checksum	2 byte	0x8910

Temperature =  $(0x08 * 256 + 0xC3) / 100 = 2243 / 100 = 22.43 \text{ } ^\circ\text{C}$

PH =  $(0x02 * 256 + 0x9E) / 100 = 670 / 100 = 6.70\text{PH}$

### 6.4.3 Function Code 6 Protocol Example

**Master Request: AA 06 RRRR VVVV CCCC**

AA	1 byte	Slave Address, 0-255
0x06	1 byte	Function Code 6
RRRR	2 byte	Register Addr (High8bits first)
VVVV	2 byte	Register Value (High8bits first)
CCCC	2 byte	CRC CHECKSUM

**Slave Response: AA 06 RRRR VVVV CCCC**

AA	1 byte	Slave Address, 0-255
0x06	1 byte	Function Code 6
RRRR	2 byte	Register Addr (High8bits first)
VVVV	2 byte	Register Value (High8bits first)
CCCC	2 byte	CRC CHECKSUM

**Example: Write Register 0x0020, that is set temperature compensation**



**Request: 01 06 0020 0000 8800**

Slave Addr.	1 byte	0x01
Function Code	1 byte	0x06
Register Addr.	2 byte	0x0020 (High8bits first)
Register Value	2 byte	0x0000 (High8bits first)
Checksum	2 byte	0x8800

**Response:01 06 0021 0001 1800**

Slave Addr.	1 byte	0x01
Function Code	1 byte	0x06
Register Addr.	2 byte	0x0020 (High8bits first)
Register Value	2 byte	0x0000 (High8bits first)
Checksum	2 byte	0x8800

### 6.4.4 Function Code 16 Protocol Example

**Master Request:AA 10 RRRR NNNN MM VVVV1 VVVV2 ...CCCC**

AA	1 byte	Slave Address,0-255
0x10	1 byte	Function Code 0x10
RRRR	2 byte	Starting Register Addr
NNNN	2 byte	Quantity of Register to write
MM	1 byte	Register Data Byte Count
VVVV1	2 byte	Register Value(High8bits first)
VVVV2	2 byte	Register Value(High8bits first)
...	...	Register Value(High8bits first)
CCCC	2 byte	CRC CHECKSUM

**Slave Response:AA 10 RRRR NNNN CCCC**

AA	1 byte	Slave Address,0-255
0x10	1 byte	Function Code 0x10
RRRR	2 byte	Starting Register Addr
NNNN	2 byte	Quantity of Register to write
CCCC	2 byte	CRC CHECKSUM

**Example:Write Register 0x0200-0x0201,that is set slave address to 1,and baudrate to 19200bp.**

**Master Request:01 10 0200 0002 04 0001 0004 BACC**

0x01	1 byte	Slave Addr.
0x10(HEX)	1 byte	Function Code 0x10
0x0200	2 byte	Starting Register Addr
0x0002	2 byte	Quantity of Register to write
0x04	1 byte	Register Data Byte Count
0x0001	2 byte	Register Value: Slave Address 1
0x0004	2 byte	Register Value: Baudrate 19200bps
0xBACC	2 byte	CRC CHECKSUM

**Salve Response:01 10 0200 0002 4070**

0x01	1 byte	Slave Addr.
0x10(HEX)	1 byte	Function Code 0x10
0x0200	2 byte	Starting Register Addr(High8bits first)
0x0002	2 byte	Quantity of Register to write(High8bits first)
0x4070	2 byte	CRC CHECKSUM

## 7. Software Configuration Utility

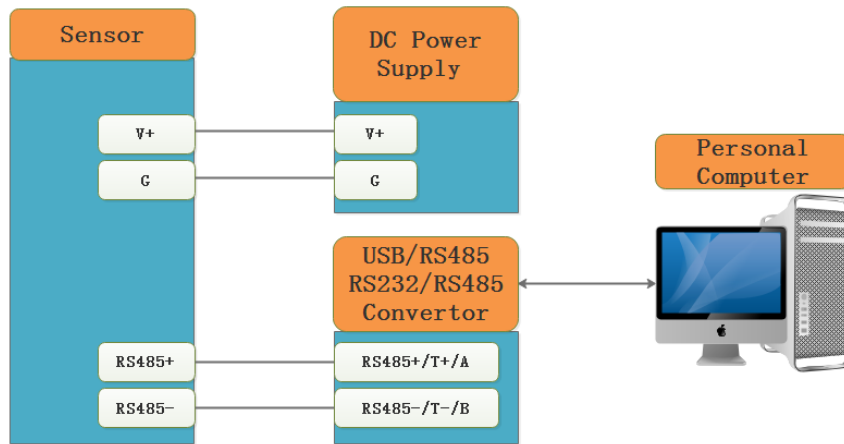

You can use software listed below to try reading/writing the register of sensor:

<https://github.com/ed-chemnitz/qmodbus/releases>

<http://qmodbus.sourceforge.net/>