

User's Manual

For

2LD545

Fully Digital Stepping Driver

Version 1.0

©2014 All Rights Reserved

Attention: Please read this manual carefully before using the driver!



MotionKing(China) Motor Industry Co., Ltd.

T: (86)519-8988 6261 F: (86)519-8515 1172

Web site: www.MotionKing.com E-Mail: sales@MotionKing.com

The content in this manual has been carefully prepared and is believed to be accurate, but no responsibility is assumed for inaccuracies.

MotionKing reserves the right to make changes without further notice to any products herein to improve reliability, function or design. MotionKing does not assume any liability arising out of the application or use of any product or circuit described herein; neither does it convey any license under its patent rights of others.

MotionKing's general policy does not recommend the use of its products in life support or aircraft applications wherein a failure or malfunction of the product may directly threaten life or injury. According to MotionKing's terms and conditions of sales, the user of MotionKing's products in life support or aircraft applications assumes all risks of such use and indemnifies MotionKing against all damages.

©2014 by MotionKing Motor Industry Co., Ltd.
All Rights Reserved

Table of Contents

1. Introduction, Features and Applications	1
Introduction	1
Features	1
Applications.....	1
2. Specifications	2
Electrical Specifications	2
Mechanical Specifications.....	2
Elimination of Heat	2
Operating Environment and other Specifications.....	3
3. Pin Assignment and Description	3
Connector P1 Configurations	3
Selecting Active Pulse Edge and Control Signal Mode.....	4
Connector P2 Configurations	4
4. Control Signal Connector (P1) Interface.....	4
5. Connecting the Motor.....	5
Connections to 4-lead Motors.....	5
Connections to 6-lead Motors.....	5
Half Coil Configurations	6
Full Coil Configurations.....	6
Connections to 8-lead Motors.....	6
Series Connections	6
Parallel Connections.....	7
6. Power Supply Selection.....	7
Regulated or Unregulated Power Supply	7
Multiple Drivers	8
Selecting Supply Voltage.....	8
7. Selecting Microstep Resolution and Driver Output Current	8
Microstep Resolution Selection.....	9
Current Settings.....	9

Dynamic current setting	10
Standstill current setting	10
8. Wiring Notes.....	10
9. Typical Connection.....	11
10. Sequence Chart of Control Signals.....	11
11. Protection Functions.....	12
Over-current Protection	12
Over-voltage Protection.....	12
Phase Error Protection.....	12
Protection Indications	12
12. Frequently Asked Questions.....	13
Problem Symptoms and Possible Causes	13

1. Introduction, Features and Applications

Introduction

The 2LD545 is a versatility fully digital stepping driver based on a DSP with advanced control algorithm. The 2LD545 is the next generation of digital stepping motor controls. It brings a unique level of system smoothness, providing optimum torque and nulls mid-range instability. Motor auto-identification and parameter auto-configuration technology offers optimum responses with different motors and easy-to-use. The driven motors can run with much smaller noise, lower heating, smoother movement than most of the drivers in the markets. Its unique features make the 2LD545 an ideal solution for applications that require low-speed smoothness.

Compared to the DM432, broader input voltage and output current ranges make the 2LD545 can drive much more motors than the DM432. What's more, owing to its higher performance DSP, driven motors can achieve much higher speed (above 3000RPM) than that of the DM432, offering servo-like performances.

Features

- Anti-Resonance, provides optimum torque and nulls mid-range instability
- Motor auto-identification and parameter auto-configuration technology, offers optimum responses with different motors
- Multi-Stepping allows a low resolution step input to produce a higher microstep output for smooth system performance
- Microstep resolutions programmable, from full-step to 102,400 steps/rev
- Supply voltage up to +50 VDC
- Output current programmable, from 1.0A to 4.5A
- Pulse input frequency up to 200 KHz
- TTL compatible and optically isolated input
- Automatic idle-current reduction
- Suitable for 2-phase and 4-phase motors
- Support PUL/DIR and CW/CCW modes
- Over-voltage, over-current, phase-error protections

Applications

Suitable for a wide range of stepping motors, from NEMA size 17 to 34. It can be used in various kinds of machines, such as laser cutters, laser markers, high precision X-Y tables, labeling machines, and so on. Its unique features make the 2LD545 an ideal solution for applications that require both low-speed smoothness and high speed performances.

2. Specifications

Electrical Specifications ($T_j = 25^\circ\text{C}/77^\circ\text{F}$)

Parameters	2LD545			
	Min	Typical	Max	Unit
Output current	1.0	-	4.5 (3.2 RMS)	A
Supply voltage	+20	+30~+40	+50	VDC
Logic signal current	7	10	16	mA
Pulse input frequency	0	-	200	kHz
Isolation resistance	500			MΩ

Mechanical Specifications (unit:mm, 1 inch = 25.4 mm)

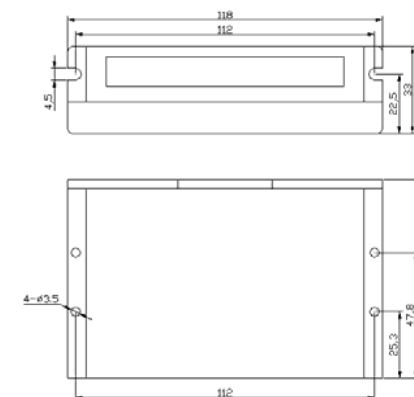

Figure 1: Mechanical specifications

Elimination of Heat

- Driver's reliable working temperature should be $<60^\circ\text{C}$ (140°F), and motor working temperature should be $<80^\circ\text{C}$ (176°F);
- It is recommended to use automatic idle-current mode, namely current automatically reduce to 60% when motor stops, so as to reduce driver heating and motor heating;
- It is recommended to mount the driver vertically to maximize heat sink area. Use forced cooling method to cool the system if necessary.

Operating Environment and other Specifications

Cooling	Natural Cooling or Forced cooling	
Operating Environment	Environment	Avoid dust, oil fog and corrosive gases
	Ambient Temperature	0°C — 50°C (32°F — 122°F)
	Humidity	40%RH — 90%RH
	Operating Temperature	70°C (158°F) Max
	Vibration	5.9m/s ² Max
Storage Temperature	-20°C — 65°C (-4°F — 149°F)	
Weight	Approx. 280g (10 oz)	

3. Pin Assignment and Description

The 2LD545 has two connectors, connector P1 for control signals connections, and connector P2 for power and motor connections. The following tables are brief descriptions of the two connectors. More detailed descriptions of the pins and related issues are presented in section 4, 5, 9.

Connector P1 Configurations

Pin Function	Details
PUL+	Pulse signal: In single pulse (pulse/direction) mode, this input represents pulse signal, each rising or falling edge active (software configurable); 4-5V when PUL-HIGH, 0-0.5V when PUL-LOW. In double pulse mode (pulse/pulse) , this input represents clockwise (CW) pulse, active both at high level and low level (software configurable). For reliable response, pulse width should be longer than 2.5μs. Series connect resistors for current-limiting when +12V or +24V used. The same as DIR and ENA signals.
PUL-	
DIR+	DIR signal: In single-pulse mode, this signal has low/high voltage levels, representing two directions of motor rotation; in double-pulse mode (software configurable), this signal is counter-clock (CCW) pulse, active both at high level and low level (software configurable). For reliable motion response, DIR signal should be ahead of PUL signal by 5μs at least. 4-5V when DIR-HIGH, 0-0.5V when DIR-LOW. Please note that rotation direction is also related to motor-driver wiring match. Exchanging the connection of two wires for a coil to the driver will reverse motion direction.
DIR-	
ENA+	Enable signal: This signal is used for enabling/disabling the driver. High level (NPN control signal, PNP and Differential control signals are on the contrary, namely Low level for enabling.) for enabling the driver and low level for disabling the driver. Usually left UNCONNECTED (ENABLED) .
ENA-	

Selecting Active Pulse Edge and Control Signal Mode

The 2LD545 supports PUL/DIR and CW/CCW modes and pulse actives at rising or falling edge. See more information about these settings in Section 13. Default setting is PUL/DIR mode and rising edge active (NPN, and PNP control signal is on the contrary).

Connector P2 Configurations

Pin Function	Details
+Vdc	Power supply, 20~50 VDC, Including voltage fluctuation and EMF voltage.
GND	Power Ground.
A+, A-	Motor Phase A
B+, B-	Motor Phase B

4. Control Signal Connector (P1) Interface

The 2LD545 can accept differential and single-ended inputs (including open-collector and PNP output). The 2LD545 has 3 optically isolated logic inputs which are located on connector P1 to accept line driver control signals. These inputs are isolated to minimize or eliminate electrical noises coupled onto the drive control signals. Recommend use line driver control signals to increase noise immunity of the driver in interference environments. In the following figures, connections to open-collector and PNP signals are illustrated.

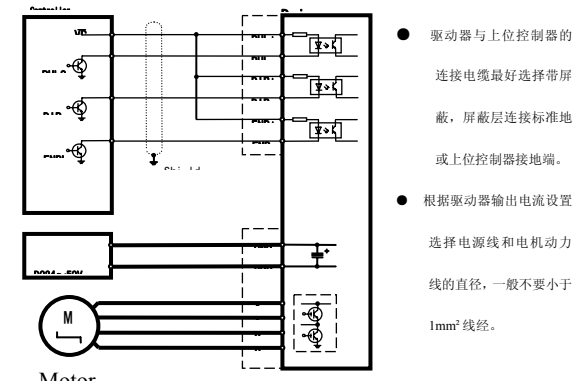

Figure 2: Connections to open-collector signal (common-anode)

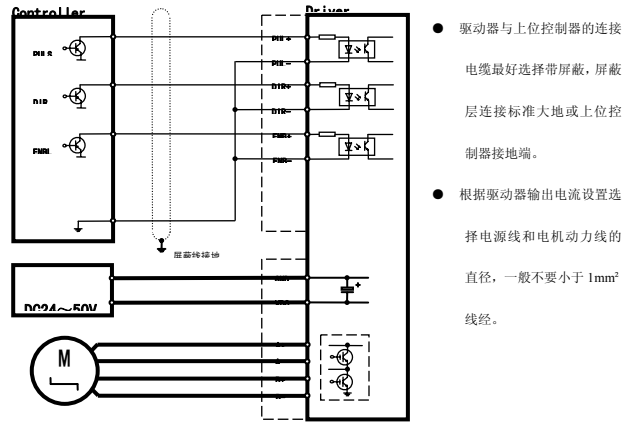

Figure 3: Connection to PNP signal (common-cathode)

5. Connecting the Motor

The 2LD545 can drive any 2-phase and 4-phase hybrid stepping motors.

Connections to 4-lead Motors

4 lead motors are the least flexible but easiest to wire. Speed and torque will depend on winding inductance. In setting the driver output current, multiply the specified phase current by 1.4 to determine the peak output current.

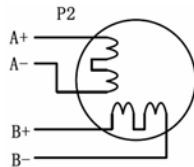

Figure 4: 4-lead Motor Connections

Connections to 6-lead Motors

Like 8 lead stepping motors, 6 lead motors have two configurations available for high speed or high torque operation. The higher speed configuration, or half coil, is so described because it uses one half of the motor's inductor windings. The higher torque configuration, or full coil, uses the full windings of the phases.

Half Coil Configurations

As previously stated, the half coil configuration uses 50% of the motor phase windings. This gives lower inductance, hence, lower torque output. Like the parallel connection of 8 lead motor, the torque output will be more stable at higher speeds. This configuration is also referred to as half chopper. In setting the driver output current multiply the specified per phase (or unipolar) current rating by 1.4 to determine the peak output current.

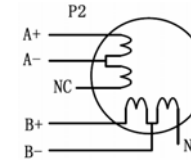

Figure 5: 6-lead motor half coil (higher speed) connections

Full Coil Configurations

The full coil configuration on a six lead motor should be used in applications where higher torque at lower speeds is desired. This configuration is also referred to as full copper. In full coil mode, the motors should be run at only 70% of their rated current to prevent over heating.

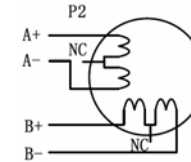

Figure 6: 6-lead motor full coil (higher torque) connections

Connections to 8-lead Motors

8 lead motors offer a high degree of flexibility to the system designer in that they may be connected in series or parallel, thus satisfying a wide range of applications.

Series Connections

A series motor configuration would typically be used in applications where a higher torque at lower speeds is required. Because this configuration has the most inductance, the performance will start to degrade at higher speeds. In series mode, the motors should also be run at only 70% of their rated current to prevent over heating.

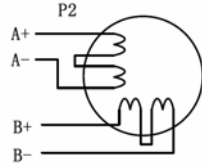

Figure 7: 8-lead motor series connections

Parallel Connections

An 8 lead motor in a parallel configuration offers a more stable, but lower torque at lower speeds. But because of the lower inductance, there will be higher torque at higher speeds. Multiply the per phase (or unipolar) current rating by 1.96, or the bipolar current rating by 1.4, to determine the peak output current.

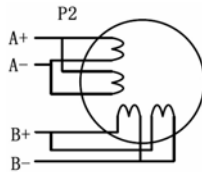

Figure 8: 8-lead motor parallel connections

NEVER disconnect or connect the motor while the power source is energized.

6. Power Supply Selection

The 2LD545 can match medium and small size stepping motors (from NEMA frame size 14 to 34) made by MotionKing or other motor manufactures around the world. To achieve good driving performances, it is important to select supply voltage and output current properly. Generally speaking, supply voltage determines the high speed performance of the motor, while output current determines the output torque of the driven motor (particularly at lower speed). Higher supply voltage will allow higher motor speed to be achieved, at the price of more noise and heating. If the motion speed requirement is low, it's better to use lower supply voltage to decrease noise, heating and improve reliability.

Regulated or Unregulated Power Supply

Both regulated and unregulated power supplies can be used to supply the driver. However, unregulated power supplies are preferred due to their ability to withstand current surge. If regulated power supplies (such as most switching supplies.) are indeed used, it is important to have large

current output rating to avoid problems like current clamp, for example using 4A supply for 3A motor-driver operation. On the other hand, if unregulated supply is used, one may use a power supply of lower current rating than that of motor (typically 50%~70% of motor current). The reason is that the driver draws current from the power supply capacitor of the unregulated supply only during the ON duration of the PWM cycle, but not during the OFF duration. Therefore, the average current withdrawn from power supply is considerably less than motor current. For example, two 3A motors can be well supplied by one power supply of 4A rating.

Multiple Drivers

It is recommended to have multiple drivers to share one power supply to reduce cost, if the supply has enough capacity. To avoid cross interference, **DO NOT** daisy-chain the power supply input pins of the drivers. Instead, please connect them to power supply separately.

Selecting Supply Voltage

The power MOSFETS inside the 2LD545 can actually operate within +20 ~ +50VDC, including power input fluctuation and back EMF voltage generated by motor coils during motor shaft deceleration. Higher supply voltage can increase motor torque at higher speeds, thus helpful for avoiding losing steps. However, higher voltage may cause bigger motor vibration at lower speed, and it may also cause over-voltage protection or even driver damage. Therefore, it is suggested to choose only sufficiently high supply voltage for intended applications, and it is suggested to use power supplies with theoretical output voltage of +20 ~ +46VDC, leaving room for power fluctuation and back-EMF.

7. Selecting Microstep Resolution and Driver Output Current

Microstep resolutions and output current are programmable, the former can be set from full-step to 102,400 steps/rev and the latter can be set from 0.5A to 5.6A. See more information about **Microstep and Output Current Setting** in Section 13.

However, when it's not in software configured mode, this driver uses an 8-bit DIP switch to set microstep resolution, and motor operating current, as shown below:

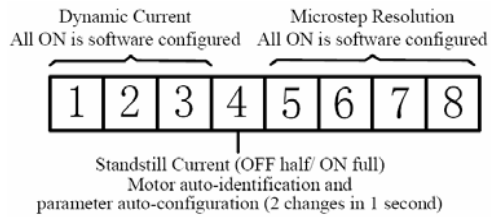

Microstep Resolution Selection

When it's not in software configured mode, microstep resolution is set by SW5, 6, 7, 8 of the DIP switch as shown in the following table:

SW5	SW6	SW7	SW8	Micro step	Pulse/rev	SW5	SW6	SW7	SW8	Micro step	Pulse/rev
ON	ON	ON	ON	1	400	ON	ON	ON	OFF	5	1000
OFF	ON	ON	ON	2	800	OFF	ON	ON	OFF	10	2000
ON	OFF	ON	ON	4	1600	ON	OFF	ON	OFF	20	4000
OFF	OFF	ON	ON	8	3200	OFF	OFF	ON	OFF	25	5000
ON	ON	OFF	ON	16	6400	ON	ON	OFF	OFF	40	8000
OFF	ON	OFF	ON	32	12800	OFF	ON	OFF	OFF	50	10000
ON	OFF	OFF	ON	64	25600	ON	OFF	OFF	OFF	100	20000
OFF	OFF	OFF	ON	128	51200	OFF	OFF	OFF	OFF	125	25000

Current Settings

For a given motor, higher driver current will make the motor to output more torque, but at the same time causes more heating in the motor and driver. Therefore, output current is generally set to be such that the motor will not overheat for long time operation. Since parallel and serial connections of motor coils will significantly change resulting inductance and resistance, it is therefore important to set driver output current depending on motor phase current, motor leads and connection methods. Phase current rating supplied by motor manufacturer is important in selecting driver current, however the selection also depends on leads and connections.

When it's not in software configured mode, the first three bits (SW1, 2, 3) of the DIP switch are used to set the dynamic current. Select a setting closest to your motor's required current.

Dynamic current setting

SW1	SW2	SW3	Peak	RMS	SW1	SW2	SW3	Peak	RMS
ON	ON	ON	1.0 A	0.71 A	ON	ON	OFF	3.0 A	2.14 A
OFF	ON	ON	1.5 A	1.07 A	OFF	ON	OFF	3.5 A	2.50 A
ON	OFF	ON	2.0 A	1.43 A	ON	OFF	OFF	4.0 A	2.86 A
OFF	OFF	ON	2.5 A	1.78 A	OFF	OFF	OFF	4.5 A	3.21 A

Notes: Due to motor inductance, the actual current in the coil may be smaller than the dynamic current setting, particularly under high speed condition.

Standstill current setting

SW4 is used for this purpose. OFF meaning that the standstill current is set to be half of the selected dynamic current, and ON meaning that standstill current is set to be the same as the selected dynamic current.

The current automatically reduced to 60% of the selected dynamic current one second after the last pulse. Theoretically, this will reduce motor heating to 36% (due to $P=I^2 \cdot R$) of the original value. If the application needs a different standstill current, please contact MotionKing.

8. Wiring Notes

- In order to improve anti-interference performance of the driver, it is recommended to use twisted pair shield cable.
- To prevent noise incurred in PUL/DIR signal, pulse/direction signal wires and motor wires should not be tied up together. It is better to separate them by at least 10 cm, otherwise the disturbing signals generated by motor will easily disturb pulse direction signals, causing motor position error, system instability and other failures.
- If a power supply serves several drivers, separately connecting the drivers is recommended instead of daisy-chaining.
- It is prohibited to pull and plug connector P2 while the driver is powered ON, because there is high current flowing through motor coils (even when motor is at standstill). Pulling or plugging connector P2 with power on will cause extremely high back-EMF voltage surge, which may damage the driver.

9. Typical Connection

A complete stepping system should include stepping motor, stepping driver, power supply and controller (pulse generator). A typical connection is shown as figure 9.

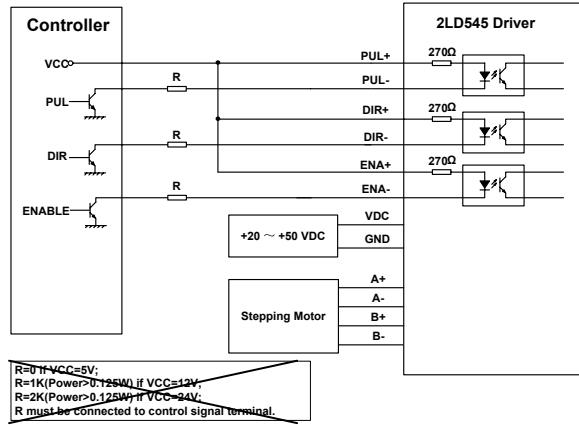

Figure 9: Typical connection

10. Sequence Chart of Control Signals

In order to avoid some fault operations and deviations, PUL, DIR and ENA should abide by some rules, shown as following diagram:

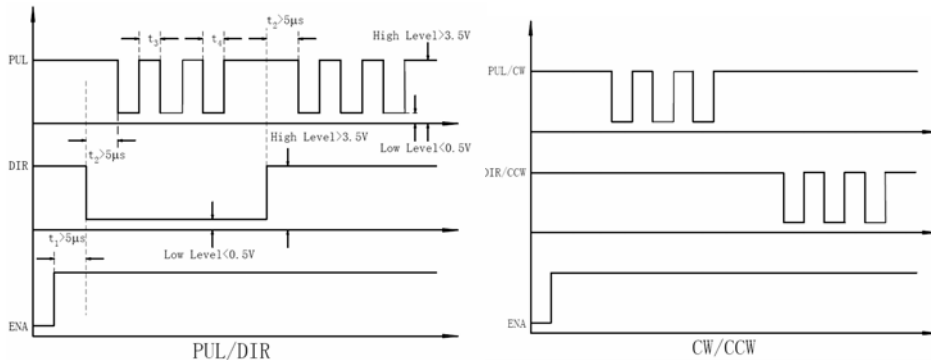

Figure 10: Sequence chart of control signals

Remark:

- a) t1: ENA must be ahead of DIR by at least 5µs. Usually, ENA+ and ENA- are NC (not connected). See “Connector P1 Configurations” for more information.

- b) t2: DIR must be ahead of PUL active edge by 5µs to ensure correct direction;
 c) t3: Pulse width not less than 2.5µs;
 d) t4: Low level width not less than 2.5µs.

11. Protection Functions

To improve reliability, the driver incorporates some built-in protection functions. The 2LD545 uses one RED LED to indicate what protection has been activated. The periodic time of RED is 3 s (seconds), and how many times the RED turns on indicates what protection has been activated. Because only one protection can be displayed by RED LED, so the driver will decide what error to display according to their priorities. See the following **Protection Indications** table for displaying priorities.

Over-current Protection

Over-current protection will be activated when continuous current exceeds 16A or in case of short circuit between motor coils or between motor coil and ground, and RED LED will turn on once within each periodic time (3 s).

Over-voltage Protection

When power supply voltage exceeds 52 ± 1 VDC, protection will be activated and RED LED will turn on twice within each periodic time (3 s).

Phase Error Protection

Motor power lines wrong & not connected will activate this protection. RED LED will turn on four times within each periodic time (3 s).

Attention: When above protections are active, the motor shaft will be free or the LED will turn red. Reset the driver by repowering it to make it function properly after removing above problems. Since there is no protection against power leads (+, -) reversal, it is critical to make sure that power supply leads correctly connected to driver. Otherwise, the driver will be damaged instantly.

Protection Indications

Priority	Time(s) of ON	Sequence wave of RED LED	Description
1 st	1		Over-current protection

2 nd	2		Over-voltage protection
3 rd	4		Phase error protection

12. Frequently Asked Questions

In the event that your driver doesn't operate properly, the first step is to identify whether the problem is electrical or mechanical in nature. The next step is to isolate the system component that is causing the problem. As part of this process you may have to disconnect the individual components that make up your system and verify that they operate independently. It is important to document each step in the troubleshooting process. You may need this documentation to refer back to at a later date, and these details will greatly assist our Technical Support staff in determining the problem should you need assistance.

Many of the problems that affect motion control systems can be traced to electrical noise, controller software errors, or mistake in wiring.

Problem Symptoms and Possible Causes

Symptoms	Possible Problems
Motor is not rotating	No power
	Microstep resolution setting is wrong
	DIP switch current setting is wrong
	Fault condition exists
	The driver is disabled
Motor rotates in the wrong direction	Motor phases may be connected in reverse
The driver in fault	DIP switch current setting is wrong
	Something wrong with motor coil
Erratic motor motion	Control signal is too weak
	Control signal is interfered
	Wrong motor connection
	Something wrong with motor coil
	Current setting is too small, losing steps

Motor stalls during acceleration	Current setting is too small
	Motor is undersized for the application
	Acceleration is set too high
Excessive motor and driver heating	Power supply voltage too low
	Inadequate heat sinking / cooling
	Automatic current reduction function not being utilized
	Current is set too high