

Electronic housing - EFG 45-LG/BS GY - 2757474

Please be informed that the data shown in this PDF Document is generated from our Online Catalog. Please find the complete data in the user's documentation. Our General Terms of Use for Downloads are valid (<http://phoenixcontact.com/download>)



Electronics housing, for insertion of two PCBs, without screw connection terminal blocks



Key Commercial Data

Packing unit	5 STK
Minimum order quantity	5 STK
GTIN	 4 017918 063566
GTIN	4017918063566
Weight per Piece (excluding packing)	148.000 g
Custom tariff number	85472000
Country of origin	Germany

Technical data

General

Housing type	Complete housing
Housing material	Polycarbonate
Color (RAL)	gray (7040)

Ambient conditions

Ambient temperature (operation)	-40 °C ... 125 °C
---------------------------------	-------------------

Dimensions

Length	118 mm
Constructional height	137.5 mm
Width	45 mm
Depth	118 mm

Technical data

Power dissipation without gap	9.5 W
-------------------------------	-------

Electronic housing - EFG 45-LG/BS GY - 2757474

Technical data

Technical data

Power dissipation with 20 mm gap	11.5 W
----------------------------------	--------

Standards and Regulations

Flammability rating according to UL 94	V0
--	----

Environmental Product Compliance

REACH SVHC	Lead 7439-92-1
China RoHS	Environmentally friendly use period: unlimited = EFUP-e
	No hazardous substances above threshold values

Drawings

Dimensional drawing

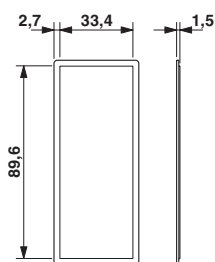

Side element (front and back)

Dimensional drawing

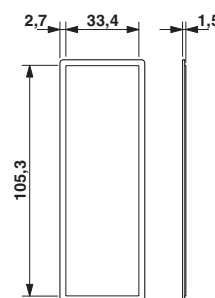

Cover element

Dimensional drawing

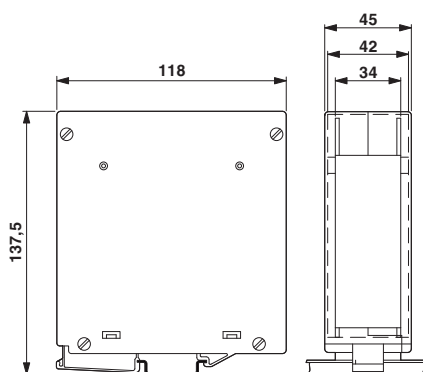

Dimensional drawing

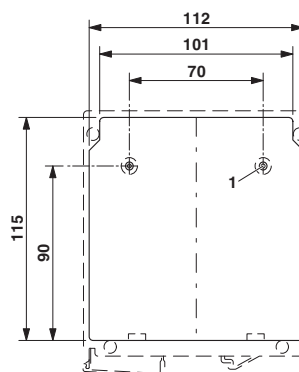

1 = Diameter 3.2 mm for M3

Classifications

eCl@ss

eCl@ss 4.0	27180401
eCl@ss 4.1	27180401
eCl@ss 5.0	27180506

Electronic housing - EFG 45-LG/BS GY - 2757474

Classifications

eCl@ss

eCl@ss 6.0	27180800
eCl@ss 7.0	27182702
eCl@ss 8.0	27182702
eCl@ss 9.0	27182702

ETIM

ETIM 2.0	EC001031
ETIM 3.0	EC001031
ETIM 4.0	EC001031
ETIM 5.0	EC001031
ETIM 6.0	EC001031

UNSPSC

UNSPSC 6.01	31261501
UNSPSC 7.0901	31261501
UNSPSC 11	31261501
UNSPSC 12.01	31261501
UNSPSC 13.2	31261501

Approvals

Approvals

Approvals

UL Recognized

Ex Approvals

Approval details

UL Recognized		http://database.ul.com/cgi-bin/XYV/template/LISEXT/1FRAME/index.htm	FILE E 240868
---------------	--	---	---------------

Accessories

Accessories

Printed circuit board terminal

Electronic housing - EFG 45-LG/BS GY - 2757474

Accessories

PCB terminal block - FRONT 2,5-H/SA 5 - 1700008



PCB terminal block, nominal current: 24 A, nom. voltage: 400 V, pitch: 5 mm, number of positions: 1, connection method: Front screw connection, mounting: Wave soldering, conductor/PCB connection direction: 0 °, color: green. The article can be aligned to create different nos. of positions!

Phoenix Contact 2018 © - all rights reserved
<http://www.phoenixcontact.com>