

PROPER USE GUIDELINES

Cumulative Trauma Disorders can result from the prolonged use of manually powered hand tools. AMP hand tools are intended for occasional use and low volume applications. AMP offers a wide selection of powered application equipment for extended-use, production operations.

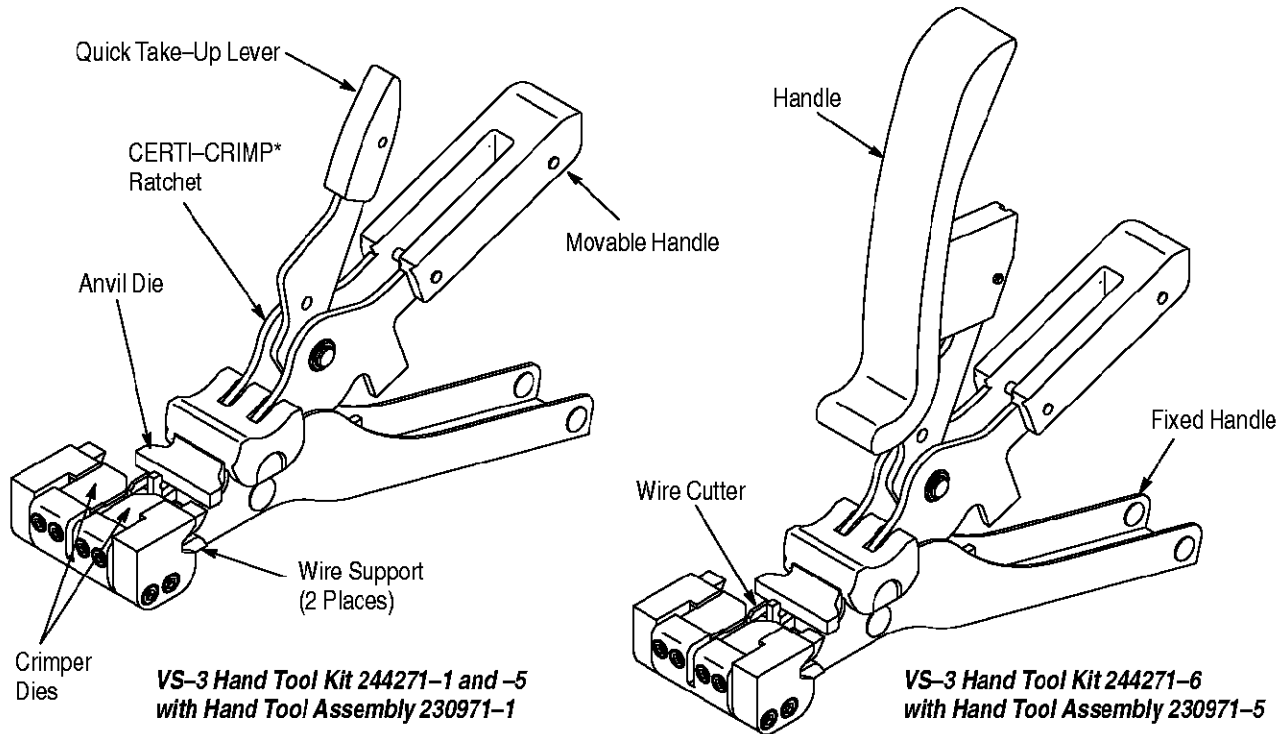

Figure 1

1. INTRODUCTION

AMP* VS-3 Hand Tool Kit 244271-1 includes a standard VS-3 hand tool assembly, crimp height gage, black nylon cord, repair tag, and a carrying case. Hand Tool Kit 244271-5 includes everything in the -1 kit plus a tool holder assembly. Hand Tool Kit 244271-6 includes everything in the -1 kit except the standard hand tool assembly is replaced with Hand Tool Assembly 230971-5. The hand tool is designed to join cable conductors (wires) using the AMP PICABOND* connectors (standard) listed in Figure 2. Read these instructions thoroughly before crimping any connectors.

The tool can be hand held or used in AMP Tool Holder 229755-1. Refer to AMP instruction sheet 408-7655 packaged with the tool holder for appropriate operating procedures.

NOTE Dimensions on this sheet are in metric units [with U.S. customary units in brackets]. Figures are not drawn to scale.

Reasons for reissue are provided in Section 11, REVISION SUMMARY.

2. DESCRIPTION (Figure 1)

The features of the hand tool and their functions are as follows:

Movable Die (Anvil) and two Fixed Dies (Crimpers)—crimp the connectors.

Wire Supports—position and hold the wires in the crimpers.

Wire Cutter—performs two functions. First, it locates the connector on the anvil, and second, it cuts excess wire during the crimp cycle.

Movable Handle (with quick take-up lever and CERTI-CRIMP ratchet)—pushes connector into crimping dies and ensures a highly uniform, finished connection every crimp cycle.

NOTE Once engaged, the ratchet will not release until the moving handle has been FULLY closed.

Fixed Handle—provides support during crimp cycle and, when applicable, can be held securely in tool holder.

Regular Connector

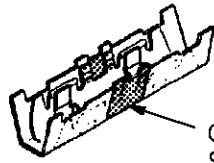

Color-Coded Stripe

Weather Resistant Connector

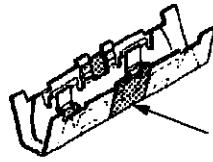

Color-Coded Stripe

Load Coil Connector

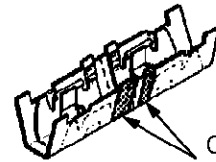

Color-Coded Stripes

WIRE SIZE RANGE (AWG)	CONNECTOR		
	DESCRIPTION	PART NUMBER	COLOR-CODED STRIPE
28-24■	Regular	61899-1	Orange
26-22■	Regular	60945-4	Green
	Weather Resistant	61226-2	Purple
	Regular Load Coil	552576-2	Green/Amber
	Breakaway Load Coil	552647-2	
	Weather Resistant Load Coil	552639-2	Purple/Amber
	Weather Resistant Breakaway Load Coil	552769-2	
24-19□	Regular	60947-3	Red
	Weather Resistant	61292-2	Yellow

- Use any one or two wire combination.
- Use only one wire size 19 AWG in combination with any other wire up to size 24 AWG per connector end.

Figure 2

3. CABLE PREPARATION

The recommended cable may include size 28 through 19 AWG copper conductors that are insulated with plastic (PIC), ribbon-paper, or pulp materials. Open and prepare the cable in the usual manner. There is no special procedure required when using the AMP VS-3 hand tool.

4. CONNECTOR SELECTION

Determine the size and combination of wires to be crimped. Then, refer to the chart in Figure 2 and select the applicable connector. Note that the PICABOND connectors (standard) have a color-coded stripe for easy identification.

5. WIRE PLACEMENT

The difference between splicing, bridging, and tapping applications is the placement of the wires in the wire supports. Determine the type of connection to be made, then refer to the applicable paragraph (5.1, 5.2, or 5.3) and insert the wires accordingly.

5.1. In-Line Splicing (Figure 3)

NOTE Always start with the cable units to the REAR of the cable opening.

1. Take a pair (tip and ring) of wires from one side of the cable opening and separate them far enough that one wire can be inserted into the wire support.

2. Lace the wire into the wire support ABOVE the pin and out between the crimpers. Make sure the wire has sufficient slack, then bottom it in the wire support.

3. Repeat steps one and two using a pair of wires from the other side of the cable opening. *Be sure to match tip to tip or ring to ring.*

4. Insert the connector into the tool, making sure the wire cutter enters the slots in the middle of the connector. Crimp the connector according to Section 6.

5.2. Bridging (Figure 4)

1. Lace the bridge wire(s) into the wire support(s) BELOW the pin(s) and out between the crimpers.

2. Take a pair (tip and ring) of wires from one side of the cable opening and separate them far enough that one wire can be inserted into the wire support.

3. Lace the wire into the wire support ABOVE the pin and out between the crimpers.

4. Repeat Steps 2 and 3 using a pair of wires from the other side of the cable opening.

5. Make sure all wires have sufficient slack, then bottom them in the wire supports. Insert the connector into the tool, making sure the wire cutter enters the slots in the middle of the connector. Crimp the connector according to Section 6.

NOTE When butt splicing, insert one wire above the pin and one wire below the pin on the same side of the tool.

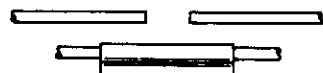
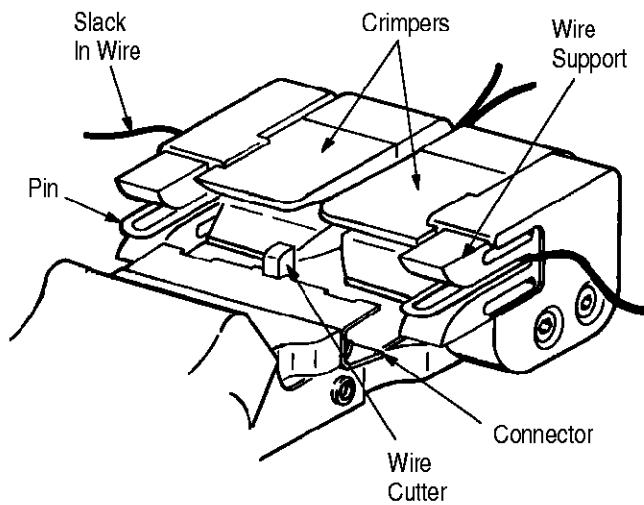

In-Line Splice

Figure 3

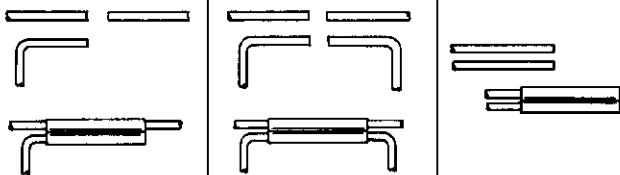
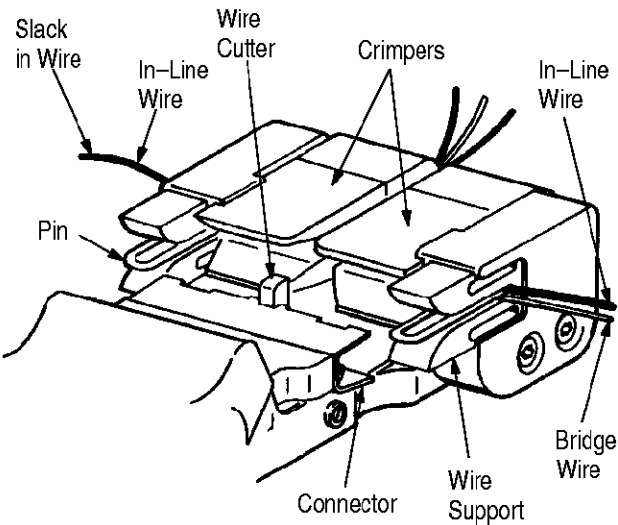

Single Bridge

Double Bridge

Butt Splice

Figure 4

5.3. Tapping (Figure 5)

The tapping connection is accomplished without cutting and interrupting service of the in-line circuit.

1. Lace the tap wire(s) into the wire support(s) **BELOW** the pin(s) and out between the crimpers.
2. Place the in-line wire into the connector. Insert the connector and in-line wire into the tool, making sure the wire cutter enters the slots in the middle of the connector. Position the in-line wire in the notch of the wire cutter, then lace it into the wire supports **ABOVE** the pins.
3. Make sure all wires have sufficient slack, then bottom them in the wire supports. Crimp the connector according to Section 6.

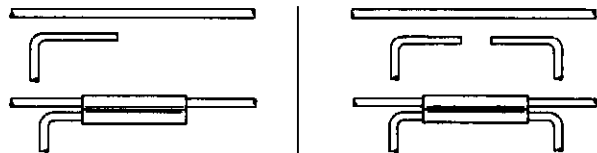
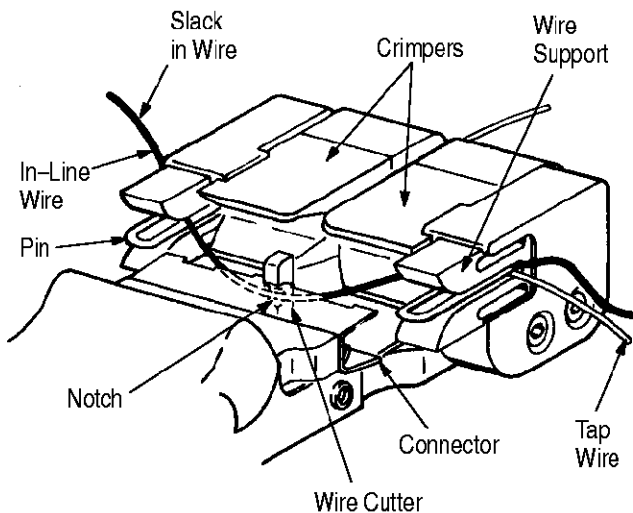

Single Half-Tap

Double Half-Tap

Figure 5

6. CRIMPING PROCEDURE

After placing the wires and the connector in the tool, crimp the connector as follows:

CAUTION

There must be sufficient slack in the wires, and the tool must be held steady during the crimping procedure. Otherwise, the wires could pull out of the connector during the crimp cycle.

1. To hold the tool steady, grasp the front portion of the fixed handle with one hand and use the other hand to close the quick take-up lever and moving handle. See Figure 6.

Cycling Tool

Figure 6

2. Squeeze the tool handles together until the CERTI-CRIMP ratchet releases. Then, allow the handles to open freely and fully.

3. Remove the crimped connector from the tool.

7. SPLICE BUILD-UP

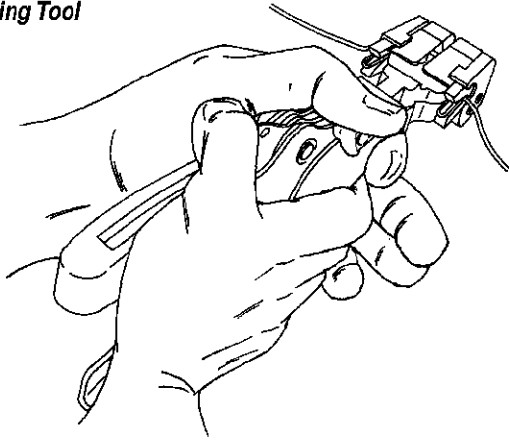
During the splicing, you should arrange groups of finished connectors along the splice opening in order to build a uniform, compact splice. To do this, move the tool along the splice opening about 31.75 mm [1.25 in.] after crimping every 25 to 50 pairs, or as local practice dictates. Alternate the direction in which the tool is moved, first to one side of center, then to the other.

8. CRIMP INSPECTION

Make the following inspections on the first—and again on the last—connection made during a shift, or as local practice dictates.

8.1. Gaging Crimped Connectors (Figure 7)

Use the crimp height gage (supplied with the tool) immediately after crimping the connection, and check the connector for the following.

1. Select the proper gage end by matching the color dot on the gage with the color strip on the connector.
2. Place the connector into the gage so the seam in the connector aligns with the double rib on the gage. Position the connector so that one end is flush with the side of the gage.
3. Hold the free end of the connector and slide the gage off using only very slight force. *The gage must slide off easily.* If it does, repeat the test for the other end of the connector.

4. If either end of the connector sticks in the gage, the connection is improperly crimped. Make a few sample crimps and gage them. If they do not engage properly, return the tool for repair. In either case, go back and re-crimp any improperly crimped connections.

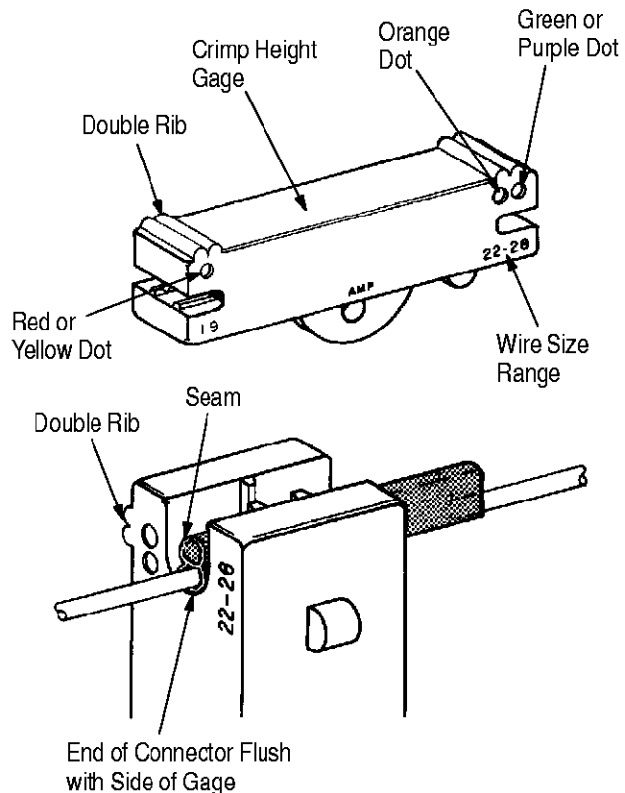

Figure 7

8.2. Visual Inspection (Figure 8)

1. Check for wire protruding from the center of the connector. If you find any, replace the connection. If this problem occurs frequently, return the tool for adjustment.
2. Make certain there are no wires missing from the connector. If there is, the tool probably moved during crimping and the connector must be replaced.
3. Check for a metal leg protruding from the center of the connector. This is caused by improper location of the connector in the tool. If you find any, replace the connections. Be especially careful to insert the connector in the tool so that the slot in the connector engages the wire cutter, and that the notch in the wire cutter, does NOT interfere with the connector. See Figures 3, 4, and 5.
4. If you are tapping or bridging, make sure the end of the connector with two conductors contains one conductor on each side of the seam.

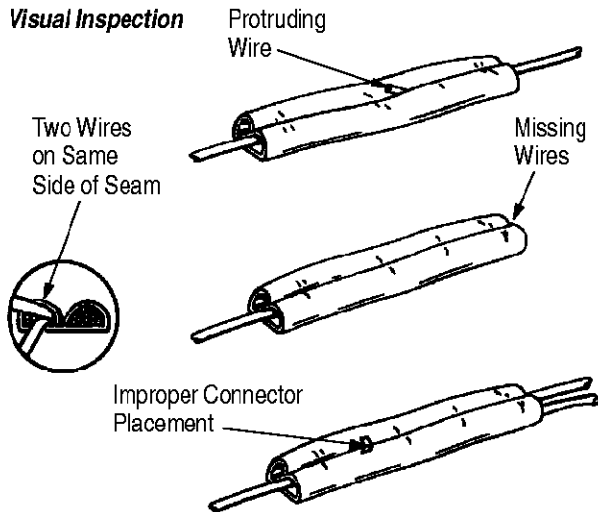

Figure 8

If both conductors are on the same side, replace the connection. Be very careful to place the conductors in the wire support correctly. If the condition persists, return the tool to your supervisor.

5. Check the plastic wire support brackets. If they are damaged, or if the pins in the supports are bent or have a rough surface, replace the supports. Use Wire Support Replacement Kit 229188-1 and follow the instructions in the kit.

9. MAINTENANCE AND INSPECTION

9.1. Inspection

The tools are inspected before shipment, and should be inspected immediately upon arrival at your facility to be sure tools have not been damaged in transit. A record of scheduled inspections should remain with each tool and/or be supplied to the personnel responsible for the tool. Though recommendations call for at least one inspection a month, the frequency should be based on:

- Care, amount of use, and handling of tool.
- Degree of operator training and skill.
- Ambient working conditions (abnormal amounts of dust, dirt, and temperature changes will necessitate more frequent inspections).
- Your established company standards.

9.2. General Cleaning

Clean and lubricate the tool at the beginning of each shift, or as local practice dictates. Use a telephone company-approved solvent cleaner or equivalent, and a commercially available lubricant, such as WD-40[■]. Also available is AMP Cleaning Kit 229333-1 which consists of a bristle brush for general purpose cleaning, a tube cleaner for cleaning the crimping dies, and a tube brush for cleaning inside the tool.

9.3. Clearing Jammed Tool

If tool becomes jammed due to a misplaced connector, complete the cycle and replace the damaged connector. If you are sure the jam is due to a hard metallic object lodged in the crimpers, return the tool to your supervisor.

10. REPLACEMENT AND REPAIR

Replacement parts are listed in Figure 9. Parts other than those listed in Figure 9 should be replaced by AMP to ensure quality and reliability of the tool. Order replacement parts through your AMP representative, or call 1-800-526-5142, or send a facsimile of your purchase order to 1-717-986-7605, or write to:

CUSTOMER SERVICE (38-35)
AMP INCORPORATED
PO BOX 3608
HARRISBURG, PA 17105-3608

For tool repair service, please contact an AMP representative at 1-800-526-5136.

11. REVISION SUMMARY

Since the previous release of this sheet, the following changes were made:

Per EC 0990-1238-99:

- Added VS-3 Hand Tool Kit 244271-6
- Updated art in Figures 1 and 9 to add Tool Kit 244271-6
- Updated Section 1, INTRODUCTION
- Changed tool repair address information in Section 10, REPLACEMENT AND REPAIR
- Updated replacement parts list in Figure 9
- Changed document title to add Hand Tool Kit 244271-6

■ Trademark of WD-40 Company, San Diego, CA

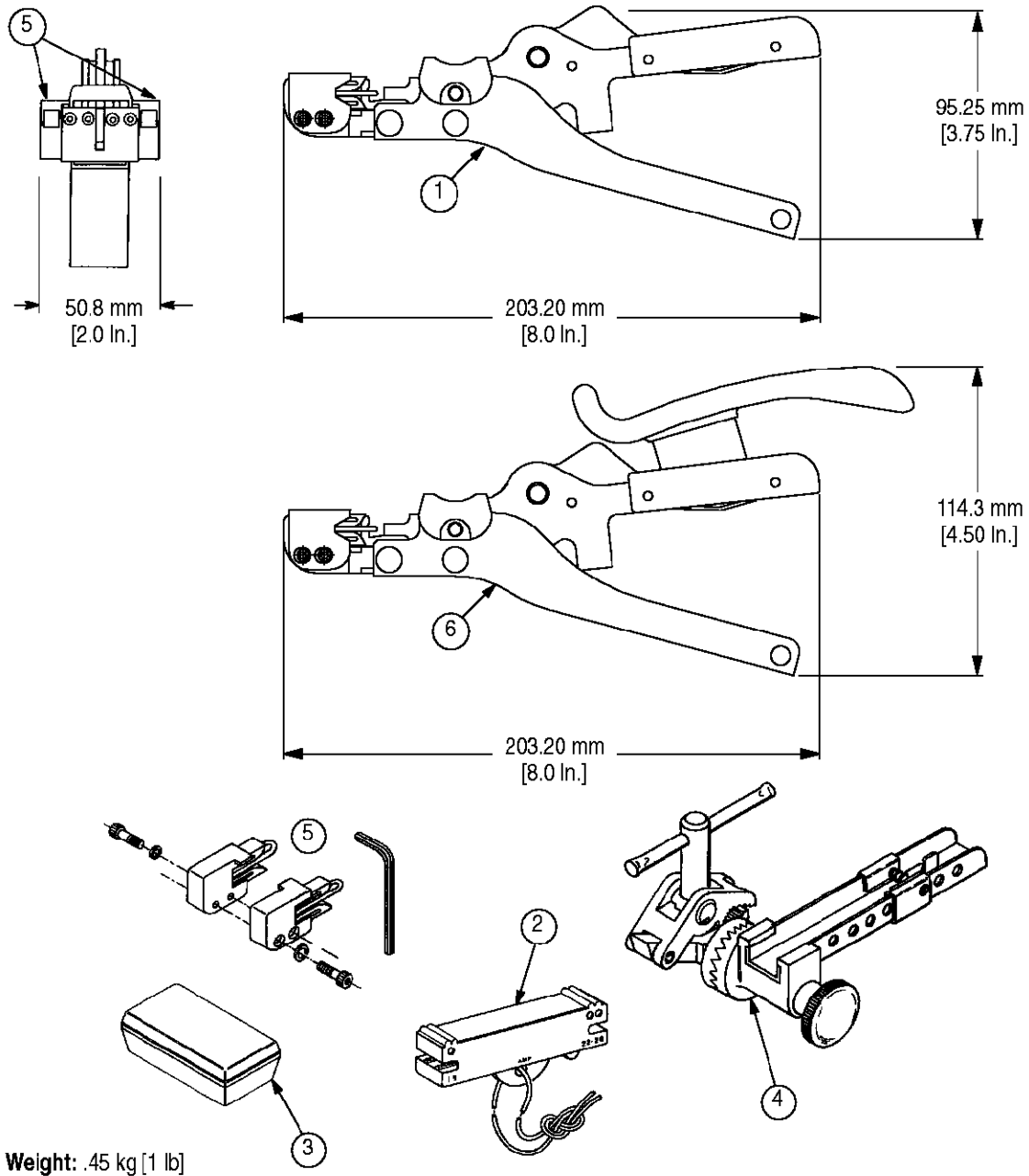

REPLACEMENT PARTS

ITEM	PART NUMBER	DESCRIPTION	QUANTITY PER HAND TOOL KIT		
			244271-1	244271-5	244271-6
1	230971-1	Hand Tool Assembly	1	1	—
2	229230-1	Crimp Height Gage Assembly	1	1	1
3	91334-1	Carrying Case	1	1	1
4	229755-1	Tool Holder Assembly	—	1	—
5	229188-1	Wire Support Replacement Kit	<i>Not Included with Kit (Reference Only)</i>		
6	230971-5	Hand Tool Assembly	—	—	1

Figure 9