

Display Elektronik GmbH

DATA SHEET

TFT MODULE

**DEM 240320J TMH-PW-N
(A-TOUCH)**

2,4" TFT + TP

Product Specification

Ver.: 3

04.01.2014

Revision History

Revision	Date	Detail	Remarks
0	24.10.2013	Initial Release	-
1	05.11.2013	Modify Interface Modify Block Diagram and Power Supply Modify Interface Pins Definition Modify AC Characteristics Modify Outline Drawing	P4 P10 P11-P12 P14-P17 P31
2	11.11.2013	Modify Module Parameter Modify Block Diagram and Power Supply Modify Interface Pins Definition Modify AC Characteristics Modify Outline Drawing	P4 P10 P11,P12 P14,P15 P31
3	04.01.2014	Add Weight Add Current Modify Touch Screen Panel Specification Modify Chromacity Transmissive Modify Outline Drawing	P5 P5 P6 P7 P31

Table of Contents

No.	Item	Page
1.	General Description	4
2.	Module Parameter	4
3.	Absolute Maximum Ratings	4
4.	DC Characteristics	5
5.	Backlight Characteristic	5
5.1.	Backlight Characteristics.....	5
5.2.	Backlighting circuit	5
6.	Touch Screen Panel Specifications.....	6
7.	Optical Characteristics	7
7.1.	Optical Characteristics	7
7.2.	Definition of Response Time	7
7.3.	Definition of Contrast Ratio	8
7.4.	Definition of Viewing Angles.....	8
7.5.	Definition of Color Appearance	9
7.6.	Definition of Surface Luminance, Uniformity and Transmittance.....	9
8.	Block Diagram and Power Supply	10
9.	Interface Pins Definition	11
10.	AC Characteristics	13
10.1.	Reset timing	13
10.2.	Display Parallel 16/8-bit Interface Timing Characteristics (8080-II system)	14
10.3.	Display Serial Interface Timing Characteristics (3-line SPI system).....	16
10.4.	Display Serial Interface Timing Characteristics (4-line SPI system).....	17
11.	Command Table	18
12.	Quality Assurance	23
12.1.	Purpose	23
12.2.	Standard for Quality Test.....	23
12.3.	Nonconforming Analysis & Disposition	23
12.4.	Agreement Items.....	23
12.5.	Standard of the Product Visual Inspection	24
12.6.	Inspection Specification	24
12.7.	Classification of Defects.....	29
12.8.	Identification/marketing criteria	29
12.9.	Packing	29
13.	Reliability Specification	30
14.	Packaging	30
15.	Outline Drawing	31

1. General Description

The specification is a transmissive type color active matrix liquid crystal display (LCD) which uses amorphous thin film transistor (TFT) as switching devices. This product is composed of a TFT-LCD panel, driver IC's, a touch panel and a backlight unit.

2. Module Parameter

Features	Details	Unit
Display Size (Diagonal)	2.4"	-
LCD Type	TN TFT	-
Display Mode	Transmissive / Normally white	-
Resolution	240 RGB x320	Pixels
View Direction	6 O'clock	Best Image
Gray Scale Inversion Direction	12 O'clock	-
Module Outline	42.72 (H) x 60.26 (V) x 3.9MAX (T) (Note1)	mm
Active Area	36.72(H) x 48.96(V)	mm
Pixel Size	153(H) x 153(V)	um
Pixel Arrangement	Stripe	-
Display Colors	262K	-
Interface	8080 MCU 8/16-Bit-Parallel Interface and 3/4-Wire Data Serial Interface	-
With Touch Panel	4-Wire-Resistive Touch-Panel integrated	-
Driver IC	ILI9341V	-
Operating Temperature	-20~70	°C
Storage Temperature	-30~80	°C
Weight	15	g

Note 1: Exclusive hooks, posts, FFC/FPC tail etc.

3. Absolute Maximum Ratings

V_{SS}=0V, Ta=25°C

Item	Symbol	Min.	Max.	Unit
Supply Voltage	VCC	-0.3	4.6	V
	VCI	-0.3	4.6	V
Storage Temperature	T _{STG}	-30	+80	°C
Operating Temperature	T _{OP}	-20	+70	°C

Note 1: If Ta below 50°C, the maximal humidity is 90%RH, if Ta over 50°C, absolute humidity should be less than 60%RH.

Note 2: The response time will be extremely slow when the operating temperature is around -10°C, and the back ground will become darker at high temperature operating.

4. DC Characteristics

Item	Symbol	Min.	Typ.	Max.	Unit	
Supply Voltage	VCC	2.5	2.8	3.3	V	
	VCI	1.65	2.8	3.3	V	
Logic Low Input Voltage	V _{IL}	GND	-	0.3*VCI	V	
Logic High Input Voltage	V _{IH}	0.7*VCI	-	VCI	V	
Logic Low Output Voltage	V _{OL}	GND	-	0.2*VCI	V	
Logic High Output Voltage	V _{OH}	0.8*VCI	-	VCI	V	
Current Consumption All Black	Logic	I _{CC+} I _{IN}	-	10	20	mA
	Analog					

5. Backlight Characteristic

5.1. Backlight Characteristics

Item	Symbol	Condition	Min	Typ	Max	Unit
Forward Voltage	V _F	Ta=25 °C, I _F =15mA/LED	2.9	3.2	3.3	V
Forward Current	I _F	Ta=25 °C, V _F =3.2V/LED	-	60	-	mA
Power Dissipation	P _D		-	192	-	mW
LED Life Time(25 °C)	-	-	(50,000)	-	-	hr
Uniformity	Avg		-	80	-	%
Drive Method	Constant Current					
LED Configuration	4 White LEDs in parallel					

Note: LED life time defined as follows: The final brightness is at 50% of original brightness.

The environmental conducted under ambient air flow, at Ta=25±2 °C, 60%RH±5%.

5.2. Backlighting Circuit

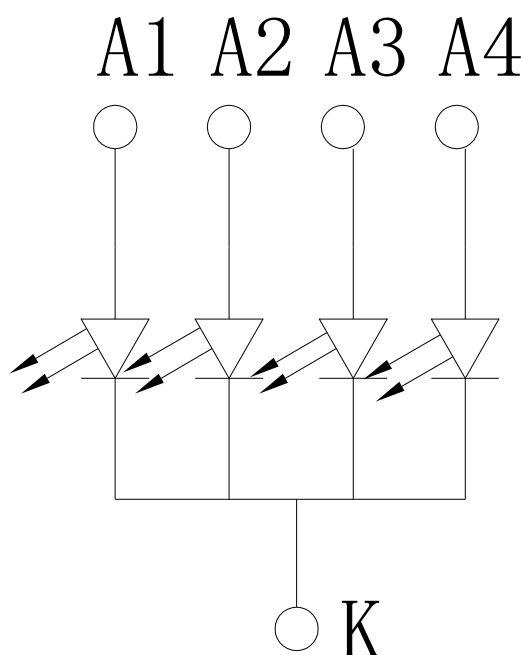

6. Touch Screen Panel Specifications**6.1 Electrical Characteristics**

Item	Min.	Typ.	Max.	Unit	Note
Linearity	(-1.5)	-	(1.5)	%	Analog X and Y directions
Terminal Resistance	(100)	-	(550)	Ω	X (Film side)
	(300)	-	(900)	Ω	Y (Glass side)
Insulation Resistance	(20)	-	-	M Ω	DC \leq 10V
Voltage	-	(5)	(10)	V	DC
Chattering	-	-	(10)	ms	

Caution (1): Touch the panel with your finger or stylus only to assure normal operation.

Any sharp edged or hard objects are prohibited.

6.2 Mechanical & Reliability Characteristics

Item	Min.	Typ.	Max.	Unit	Note
Activation Force	20	-	100	g	(1)
Durability-Surface Scratching	Write (100,000)	-	-	characters	(2)
Durability-Surface Pitting	(1,000,000)	-	-	touches	(3)
Surface Hardness	(3)	-	-	H	

Note (1) Touch Input: R8.0mm silicone Finger

Note (2) Measurement for Surface area - Scratch 100,000 times straight line on the Film with a stylus change every 20,000times

- Force: 150-250gf
- Speed: 60mm/sec
- Stylus: R0.8 silicone Finger

Note (3) Pit 1,000,000 times on the Film with a R3.75 silicon rubber.

- Force: Force: 2.45N
- Speed: 3times/sec

7. Optical Characteristics

7.1. Optical Characteristics

Ta=25°C, VCC=2.8V, TN LC+ Polarizer

	Item	Symbol	Condition	Specification			Unit	
				Min.	Typ.	Max.		
Backlight On (Transmissive Mode)	Luminance on TFT ($I_f=15\text{mA/LED}$)	Lv	Normally viewing angle $\theta_x = \phi_y = 0^\circ$	160	200	-	cd/m ²	
	Contrast ratio(See 7.3)	CR		400	500	-		
	Response Time (See 7.2)	TR+TF		-	20	30	ms	
	Chromaticity Transmissive (See 7.5)	Red	XR	Center CR≥10	0.575	0.625	0.675	
			YR		0.274	0.324	0.374	
		Green	XG		0.268	0.318	0.368	
			YG		0.540	0.590	0.640	
		Blue	XB		0.093	0.143	0.193	
			YB		0.052	0.102	0.152	
	White	XW	0.258	0.308	0.358			
YW		0.298	0.348	0.398				
Viewing Angle (See 7.4)	Horizontal	θ_{x+}	Center CR≥10	60	70	-	Deg.	
		θ_{x-}		60	70	-		
	Vertical	ϕ_{y+}		60	70	-		
		ϕ_{y-}		50	60	-		
NTSC Ratio(Gamut)				-	60	-	%	

7.2. Definition of Response Time

7.2.1. Normally Black Type (Negative)

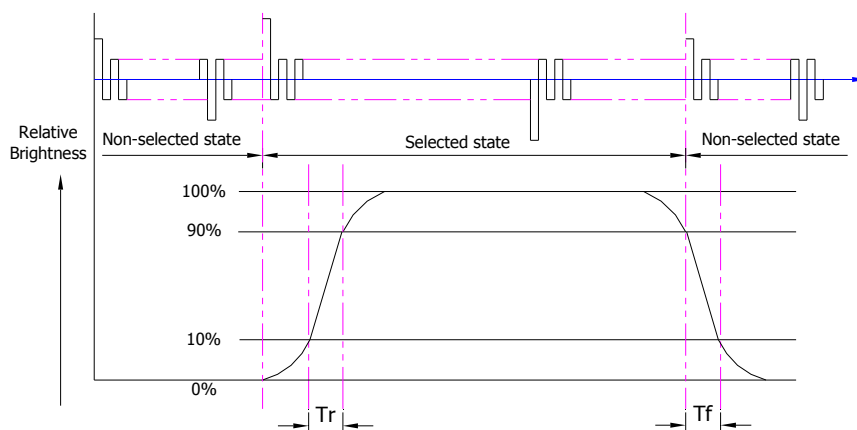

Tr is the time it takes to change form non-selected stage with relative luminance 10% to selected state with relative luminance 90%;

Tf is the time it takes to change from selected state with relative luminance 90% to non-selected state with relative luminance 10%.

Note : Measuring machine: LCD-5100

7.2.2. Normally White Type (Positive)

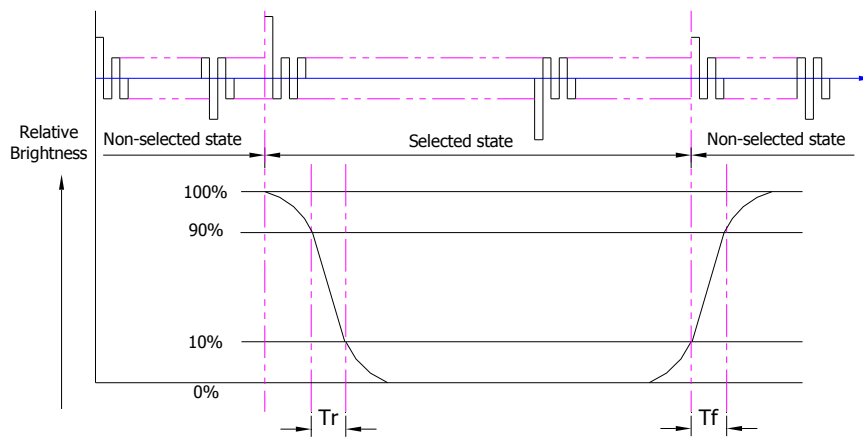

Tr is the time it takes to change from non-selected state with relative luminance 90% to selected state with relative luminance 10%;

Tf is the time it takes to change from selected state with relative luminance 10% to non-selected state with relative luminance 90%;

Note: Measuring machine: LCD-5100 or EQUI

7.3. Definition of Contrast Ratio

Contrast is measured perpendicular to display surface in reflective and transmissive mode. The measurement condition is:

Measuring Equipment	Eldim or Equivalent
Measuring Point Diameter	3mm//1mm
Measuring Point Location	Active Area centre point
Test pattern	A: All Pixels white
	B: All Pixel black
Contrast setting	Maximum

Definitions: CR (Contrast) = Luminance of White Pixel / Luminance of Black Pixel

7.4. Definition of Viewing Angles

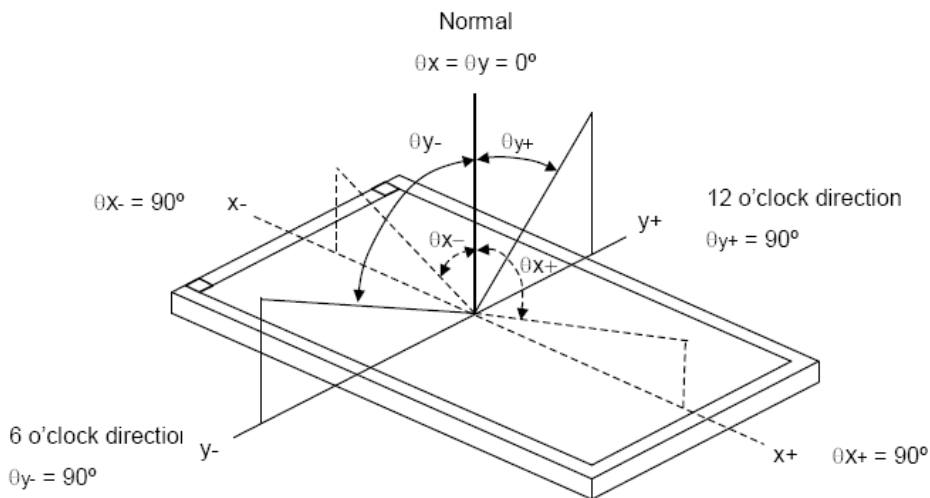

Measuring machine: LCD-5100 or EQUI

7.5. Definition of Color Appearance

R,G,B and W are defined by (x, y) on the IE chromaticity diagram

NTSC=area of RGB triangle/area of NTSC triangleX100%

Measuring picture: Red, Green, Blue and White (Measuring machine: BM-7)

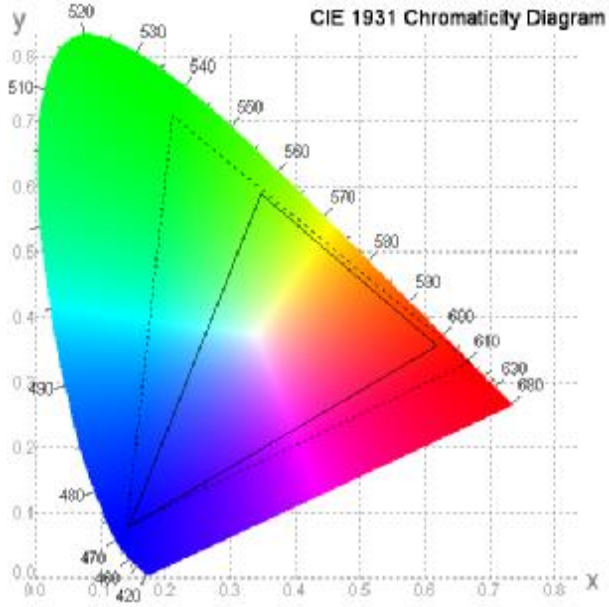

7.6. Definition of Surface Luminance, Uniformity and Transmittance

Using the transmissive mode measurement approach, measure the white screen luminance of the display panel and backlight.

7.6.1. Surface Luminance: $L_v = \text{average} (L_{P1}:L_{P9})$

7.6.2. Uniformity = $\text{Minimal} (L_{P1}:L_{P9}) / \text{Maximal} (L_{P1}:L_{P9}) * 100\%$

7.6.3. Transmittance = $L_v \text{ on LCD} / L_v \text{ on Backlight} * 100\%$

Note: Measuring machine: BM-7

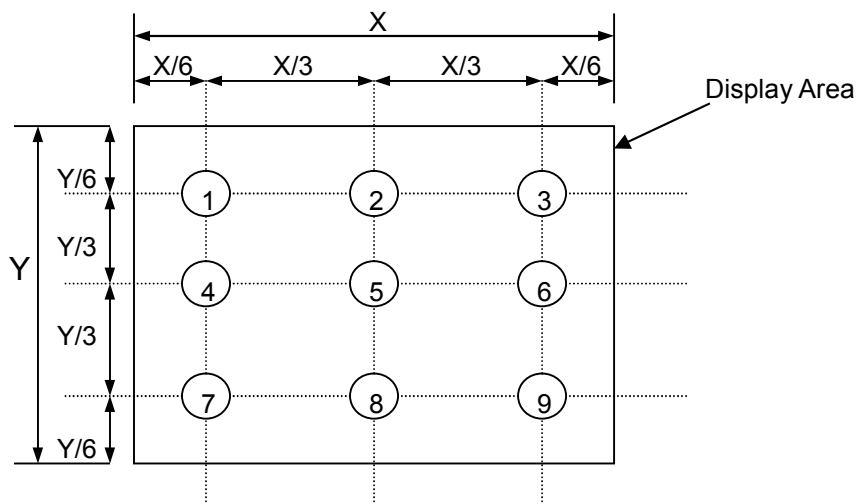

8. Block Diagram and Power Supply

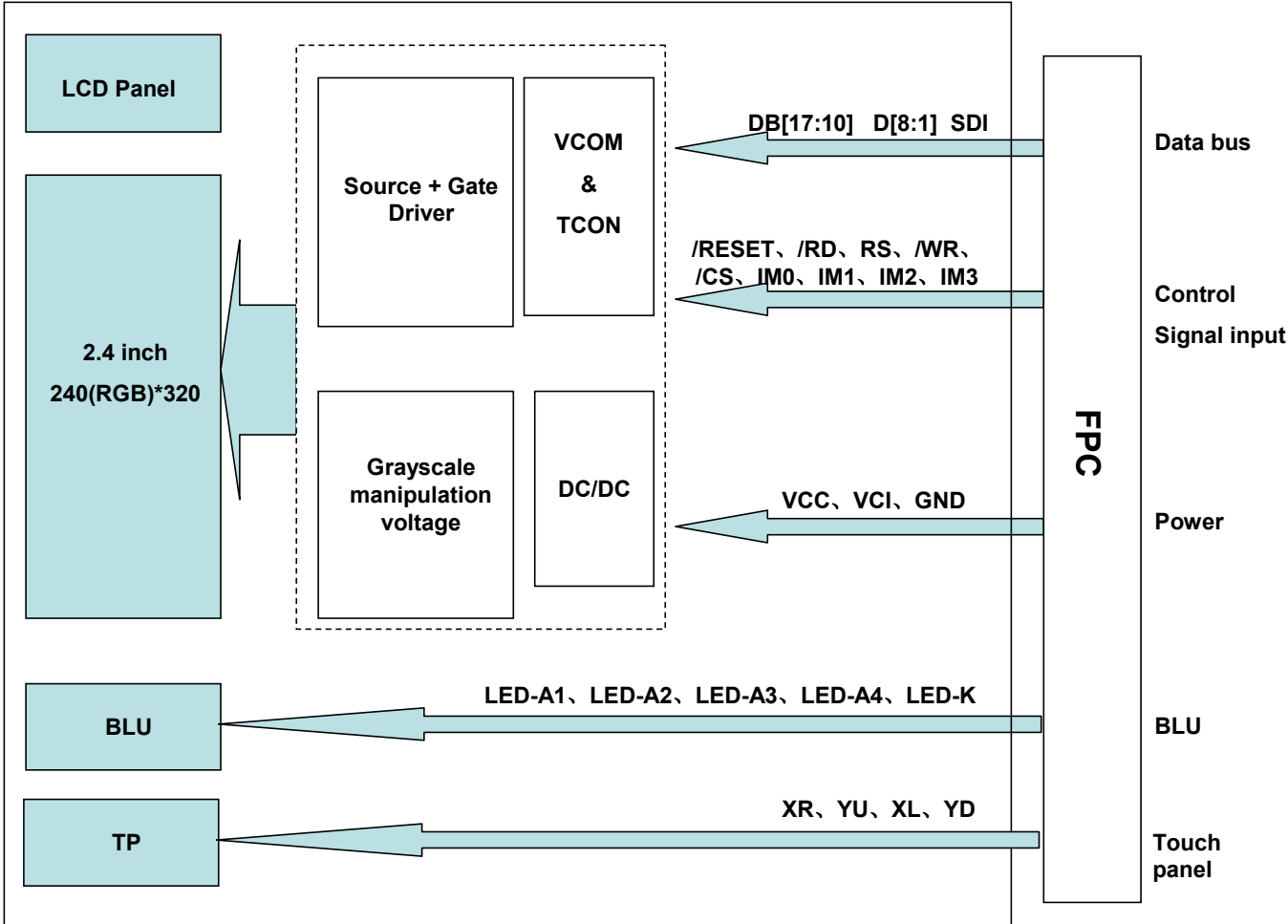

9. Interface Pins Definition

No.	Symbol	Function	Remark																																					
1	DB10	Data bus.																																						
2	DB11	Data bus.																																						
3	DB12	Data bus.																																						
4	DB13	Data bus.																																						
5	GND	Ground.																																						
6	VCC	Power supply: +2.8V.																																						
7	/CS	L: Chip Selected; H: Chip Unselected.																																						
8	RS	L: Command; H: Display data.																																						
9	/WR	Write signal.																																						
10	/RD	Read signal.																																						
11	IM0	Select the MCU interface mode <table border="1"> <thead> <tr> <th rowspan="2">IM3</th> <th rowspan="2">IM2</th> <th rowspan="2">IM1</th> <th rowspan="2">IM0</th> <th rowspan="2">MCU Interface Mode</th> <th colspan="2">DB Pin in use</th> </tr> <tr> <th>Register /Content</th> <th>GRAM</th> </tr> </thead> <tbody> <tr> <td>1</td> <td>0</td> <td>0</td> <td>0</td> <td>80 MCU 16-bit bus Interface II</td> <td>D[8:1]</td> <td>D[17:10] D[8:1]</td> </tr> <tr> <td>1</td> <td>0</td> <td>0</td> <td>1</td> <td>80 MCU 8-bit bus Interface II</td> <td>D[17:10]</td> <td>D[17:10]</td> </tr> <tr> <td>1</td> <td>1</td> <td>0</td> <td>1</td> <td>3-wire 9-bit data serial interface II</td> <td colspan="2">SDI:In SDO:OUT</td> </tr> <tr> <td>1</td> <td>1</td> <td>1</td> <td>0</td> <td>4-wire 8-bit data serial interface II</td> <td colspan="2">SDI:In SDO:OUT</td> </tr> </tbody> </table>	IM3	IM2	IM1	IM0	MCU Interface Mode	DB Pin in use		Register /Content	GRAM	1	0	0	0	80 MCU 16-bit bus Interface II	D[8:1]	D[17:10] D[8:1]	1	0	0	1	80 MCU 8-bit bus Interface II	D[17:10]	D[17:10]	1	1	0	1	3-wire 9-bit data serial interface II	SDI:In SDO:OUT		1	1	1	0	4-wire 8-bit data serial interface II	SDI:In SDO:OUT		
IM3	IM2							IM1	IM0	MCU Interface Mode	DB Pin in use																													
			Register /Content	GRAM																																				
1	0		0	0	80 MCU 16-bit bus Interface II	D[8:1]	D[17:10] D[8:1]																																	
1	0		0	1	80 MCU 8-bit bus Interface II	D[17:10]	D[17:10]																																	
1	1	0	1	3-wire 9-bit data serial interface II	SDI:In SDO:OUT																																			
1	1	1	0	4-wire 8-bit data serial interface II	SDI:In SDO:OUT																																			
12	IM3																																							
13	IM2																																							
14	SDI	SPI interface input pin.																																						
15	SDO	SPI interface output pin.																																						
16	YU	Touch panel terminal.																																						
17	XL	Touch panel terminal.																																						
18	YD	Touch panel terminal.																																						
19	XR	Touch panel terminal.																																						
20	LED-K	LED Cathode.																																						
21	LED-A1	LED Anode.																																						
22	LED-A2	LED Anode.																																						
23	LED-A3	LED Anode.																																						
24	LED-A4	LED Anode.																																						
25	DB14	Data bus.																																						
26	DB1	Data bus.																																						
27	DB2	Data bus.																																						
28	DB3	Data bus.																																						
29	DB4	Data bus.																																						
30	DB5	Data bus.																																						
31	DB6	Data bus.																																						

32	DB7	Data bus.	
33	DB8	Data bus.	
34	/RESET	L: Initialization is executed.	
35	VCI	A Power supply for step-up circuit and power supply circuit.	
36	VCC	Power supply:+2.8V.	
37	IM1	Select the MCU interface mode with IM0, IM3, IM2.	
38	DB15	Data bus.	
39	DB16	Data bus.	
40	DB17	Data bus.	

10. AC Characteristics

10.1.Reset timing

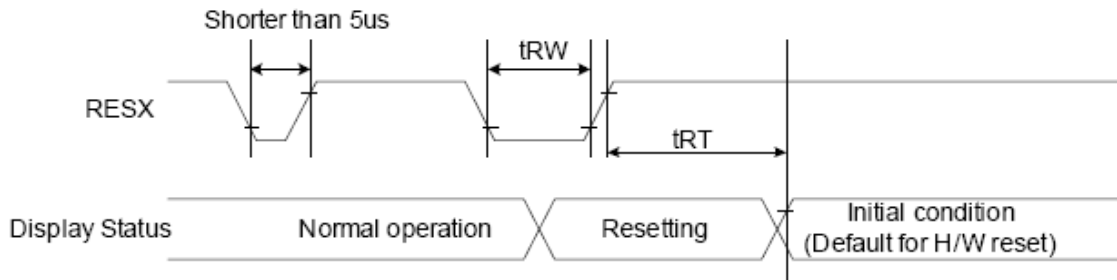

Signal	Symbol	Parameter	Min	Max	Unit
RESX	tRW	Reset pulse duration	10		uS
	tRT	Reset cancel		5 (note 1,5)	mS
				120 (note 1,6,7)	mS

Note 1: The reset cancel includes also required time for loading ID bytes, VCOM setting and other settings from NV memory to registers. This loading is done every time when there is HW reset cancel time (tRT) within 5 ms after a rising edge of RESX.

Note 2: Spike due to an electrostatic discharge on RESX line does not cause irregular system reset according to the table below: -

RESX Pulse	Action
Shorter than 5us	Reset Rejected
Longer than 10us	Reset
Between 5us and 10us	Reset starts

Note 3: During the Resetting period, the display will be blanked (The display is entering blanking sequence, which maximum time is 120 ms, when Reset Starts in Sleep Out –mode. The display remains the blank state in Sleep In -mode.) And then return to Default condition for Hardware Reset.

Note 4: Spike Rejection also applies during a valid reset pulse as shown below:

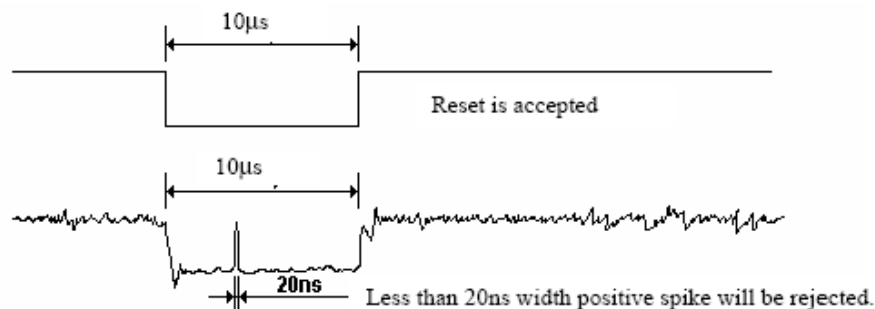

Note 5: When Reset applied during Sleep In Mode.

Note 6: When Reset applied during Sleep Out Mode.

Note 7: It is necessary to wait 5msec after releasing RESX before sending commands. Also Sleep Out command cannot be sent for 120msec.

CSX timings :

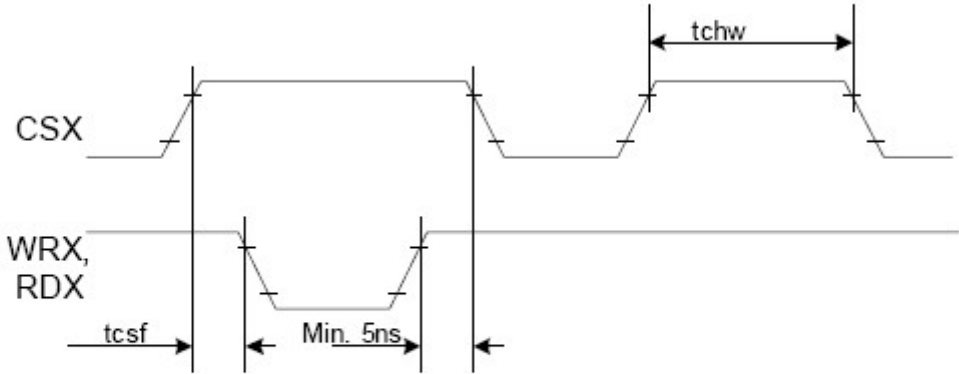

Note: Logic high and low levels are specified as 30% and 70% of VDDI for Input signals.

Write to read or read to write timings:

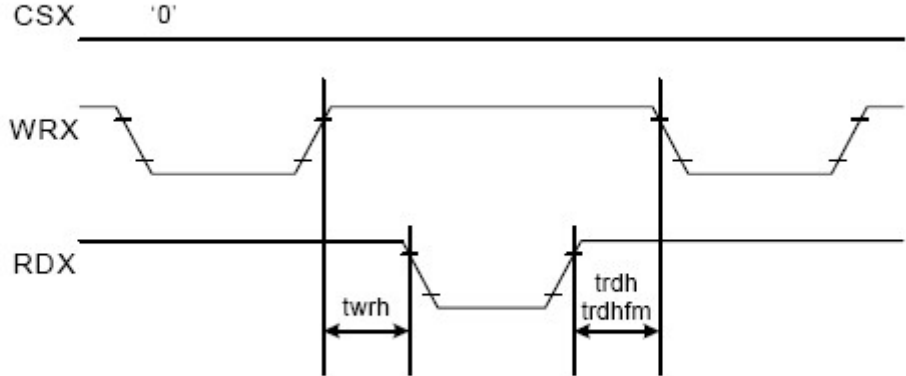

Note: Logic high and low levels are specified as 30% and 70% of VDDI for Input signals.

10.3. Display Serial Interface Timing Characteristics (3-line SPI system)

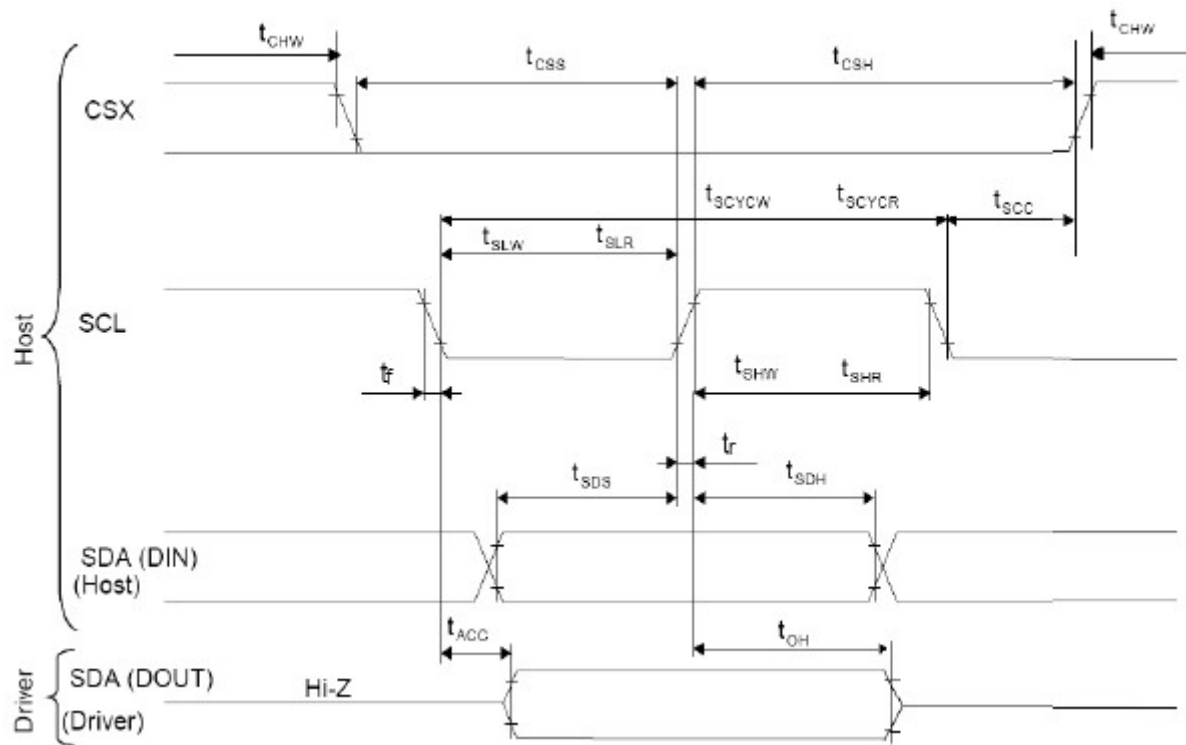

Signal	Symbol	Parameter	min	max	Unit	Description
SCL	tscycw	Serial Clock Cycle (Write)	100	-	ns	
	tshw	SCL "H" Pulse Width (Write)	40	-	ns	
	tslw	SCL "L" Pulse Width (Write)	40	-	ns	
	tscycr	Serial Clock Cycle (Read)	150	-	ns	
	tshr	SCL "H" Pulse Width (Read)	60	-	ns	
	tslr	SCL "L" Pulse Width (Read)	60	-	ns	
SDA / SDI (Input)	tsds	Data setup time (Write)	30	-	ns	
	tsdh	Data hold time (Write)	30	-	ns	
SDA / SDO (Output)	tacc	Access time (Read)	10	-	ns	
	toh	Output disable time (Read)	10	50	ns	
CSX	tsc	SCL-CSX	20	-	ns	
	tch	CSX "H" Pulse Width	40	-	ns	
	tc	CSX-SCL Time	60	-	ns	
	ts		65	-	ns	

Note: $T_a = 25\text{ }^\circ\text{C}$, $V_{DDI}=1.65\text{V to }3.3\text{V}$, $V_{CI}=2.5\text{V to }3.3\text{V}$, $AGND=V_{SS}=0\text{V}$

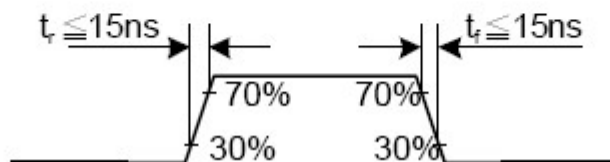

10.4. Display Serial Interface Timing Characteristics (4-line SPI system)

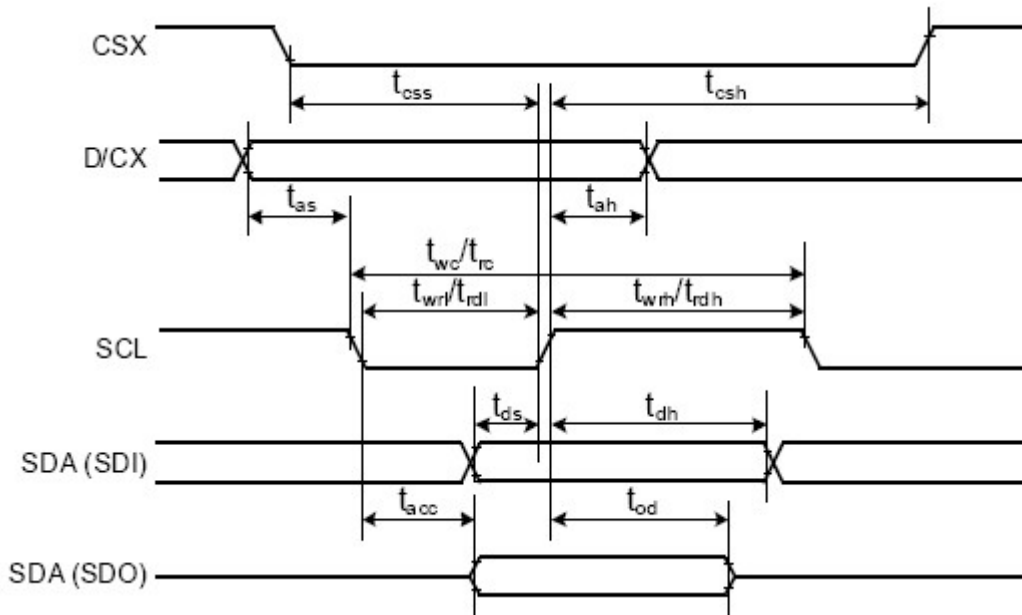

Signal	Symbol	Parameter	min	max	Unit	Description
CSX	tcss	Chip select time (Write)	40	-	ns	
	tcsh	Chip select hold time (Read)	40	-	ns	
SCL	twc	Serial clock cycle (Write)	100	-	ns	
	twrh	SCL "H" pulse width (Write)	40	-	ns	
	twrl	SCL "L" pulse width (Write)	40	-	ns	
	trc	Serial clock cycle (Read)	150	-	ns	
	trdh	SCL "H" pulse width (Read)	60	-	ns	
	trdl	SCL "L" pulse width (Read)	60	-	ns	
D/CX	tas	D/CX setup time	10	-		
	tah	D/CX hold time (Write / Read)	10	-		
SDA / SDI (Input)	tds	Data setup time (Write)	30	-	ns	
	tdh	Data hold time (Write)	30	-	ns	
SDA / SDO (Output)	tacc	Access time (Read)	10	-	ns	For maximum CL=30pF
	tod	Output disable time (Read)	10	50	ns	For minimum CL=8pF

Note: $T_a = 25\text{ }^\circ\text{C}$, $V_{DDI}=1.65\text{V to }3.3\text{V}$, $V_{CI}=2.5\text{V to }3.3\text{V}$, $AGND=VSS=0\text{V}$

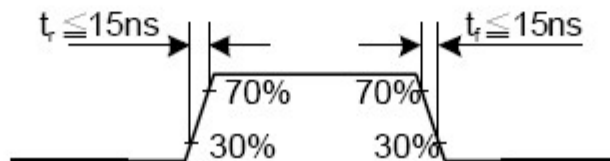

11. Command Table

Regulative Command Set													
Command Function	D/CX	RDX	WRX	D17-8	D7	D6	D5	D4	D3	D2	D1	D0	Hex
No Operation	0	1	↑	XX	0	0	0	0	0	0	0	0	00h
Software Reset	0	1	↑	XX	0	0	0	0	0	0	0	1	01h
Read Display Identification Information	0	1	↑	XX	0	0	0	0	0	1	0	0	04h
	1	↑	↑	XX	X	X	X	X	X	X	X	X	XX
	1	↑	↑	XX	ID1 [7:0]							XX	
	1	↑	↑	XX	ID2 [7:0]							XX	
	1	↑	↑	XX	ID3 [7:0]							XX	
Read Display Status	0	1	↑	XX	0	0	0	0	1	0	0	1	00h
	1	↑	↑	XX	X	X	X	X	X	X	X	X	XX
	1	↑	↑	XX	D [31:25]							X	00
	1	↑	↑	XX	X	D [22:20]			D [19:18]			61	
	1	↑	↑	XX	X	X	X	X	X	D [10:8]			00
	1	↑	↑	XX	D [7:5]			X	X	X	X	X	00
Read Display Power Mode	0	1	↑	XX	0	0	0	0	1	0	1	0	0Ah
	1	↑	↑	XX	X	X	X	X	X	X	X	X	XX
	1	↑	↑	XX	D [7:2]						0	0	08
Read Display MADCTL	0	1	↑	XX	0	0	0	0	1	0	1	1	0Bh
	1	↑	↑	XX	X	X	X	X	X	X	X	X	XX
	1	↑	↑	XX	D [7:2]						0	0	00
Read Display Pixel Format	0	1	↑	XX	0	0	0	0	1	1	0	0	0Ch
	1	↑	↑	XX	X	X	X	X	X	X	X	X	XX
	1	↑	↑	XX	RIM	DPI [2:0]		X	DDI [2:0]				06
Read Display Image Format	0	1	↑	XX	0	0	0	0	1	1	0	1	0Dh
	1	↑	↑	XX	X	X	X	X	X	X	X	X	XX
	1	↑	↑	XX	X	X	X	X	X	D [2:0]			00
Read Display Signal Mode	0	1	↑	XX	0	0	0	0	1	1	1	0	0Eh
	1	↑	↑	XX	X	X	X	X	X	X	X	X	XX
	1	↑	↑	XX	D [7:2]						0	0	00
Read Display Self Diagnostic Result	0	1	↑	XX	0	0	0	0	1	1	1	1	0Fh
	1	↑	↑	XX	X	X	X	X	X	X	X	X	XX
	1	↑	↑	XX	D [7:8]							X	X
Enter Sleep Mode	0	1	↑	XX	0	0	0	1	0	0	0	0	10h
Sleep OUT	0	1	↑	XX	0	0	0	1	0	0	0	1	11h
Partial Mode ON	0	1	↑	XX	0	0	0	1	0	0	1	0	12h
Normal Display Mode ON	0	1	↑	XX	0	0	0	1	0	0	1	1	13h
Display Inversion OFF	0	1	↑	XX	0	0	1	0	0	0	0	0	20h
Display Inversion ON	0	1	↑	XX	0	0	1	0	0	0	0	1	21h
Gamma Set	0	1	↑	XX	0	0	1	0	0	1	1	0	28h
	1	↑	↑	XX	GC [7:0]							01	
Display OFF	0	1	↑	XX	0	0	1	0	1	0	0	0	28h
Display ON	0	1	↑	XX	0	0	1	0	1	0	0	1	29h
Column Address Sel	0	1	↑	XX	0	0	1	0	1	0	1	0	2Ah
	1	↑	↑	XX	SC [15:8]							XX	
	1	↑	↑	XX	SC [7:0]							XX	
	1	↑	↑	XX	FC [15:8]							XX	
	1	↑	↑	XX	LC [7:0]							XX	
Page Address Set	0	1	↑	XX	0	0	1	0	1	0	1	1	2Bh
	1	↑	↑	XX	SP [15:8]							XX	
	1	↑	↑	XX	SP [7:0]							XX	
	1	↑	↑	XX	FP [15:8]							XX	
1	↑	↑	XX	CP [7:0]							XX		

Memory Write	0	1	↑	XX	0	0	1	0	1	1	0	0	2Ch		
	1	1	↑		D [17:0]								XX		
Color SET	0	1	↑	XX	0	0	1	0	1	1	0	1	20h		
	1	↑	1	XX									R00 [5:0]	XX	
	1	↑	1	XX									Rnn [5:0]	XX	
	1	↑	1	XX									R31 [5:0]	XX	
	1	↑	1	XX									G00 [5:0]	XX	
	1	↑	1	XX									Gnn [5:0]	XX	
	1	↑	1	XX									G64 [5:0]	XX	
	1	↑	1	XX									B00 [5:0]	XX	
	1	↑	1	XX									Bnn [5:0]	XX	
	1	↑	1	XX									B31 [5:0]	XX	
Memory Read	0	1	↑	XX	0	0	1	0	1	1	1	0	2Hh		
	1	↑	1	XX	X	X	X	X	X	X	X	X	XX		
	1	↑	1		D [17:0]								XX		
Partial Area	0	1	↑	XX	0	0	1	1	0	0	0	0	30h		
	1	1	↑	XX									SR [15:8]	00	
	1	1	↑	XX									SR [7:0]	00	
	1	1	↑	XX									LR [15:8]	01	
	1	1	↑	XX									LR [7:0]	3F	
Vertical Scrolling Definition	0	1	↑	XX	0	0	1	1	0	0	1	1	33h		
	1	1	↑	XX									TFA [15:8]	00	
	1	1	↑	XX									TFA [7:0]	00	
	1	1	↑	XX									VSA [15:8]	01	
	1	1	↑	XX									VSA [7:0]	40	
	1	1	↑	XX									BFA [15:8]	00	
1	1	↑	XX									BFA [7:0]	00		
Tearing Effect Line OFF	0	1	↑	XX	0	0	1	1	0	1	0	0	34h		
Tearing Effect Line ON	0	1	↑	XX	0	0	1	1	0	1	0	1	35h		
	1	1	↑	XX	X	X	X	X	X	X	X	M	00		
Memory Access Control	0	1	↑	XX	0	0	1	1	0	1	1	0	36h		
	1	1	↑	XX	MY	MX	MV	ML	BCR	MH	X	X	00		
Vertical Scrolling Start Address	0	1	↑	XX	0	0	1	1	0	1	1	1	37h		
	1	1	↑	XX									VSP [15:8]	00	
	1	1	↑	XX									VSP [7:0]	00	
Idle Mode OFF	0	1	↑	XX	0	0	1	1	1	0	0	0	38h		
Idle Mode ON	0	1	↑	XX	0	0	1	1	1	0	0	1	39h		
Pixel Format Set	0	1	↑	XX	0	0	1	1	1	0	1	0	3Ah		
	1	1	↑	XX	X								DP1 [2:0]	X	DP0 [2:0]
Write Memory Continue	0	1	↑	XX	0	0	1	1	1	1	0	0	3Ch		
	1	1	↑		D [17:0]								XX		
Read Memory Continue	0	1	↑	XX	0	0	1	1	1	1	1	0	3Eh		
	1	↑	1	XX	X	X	X	X	X	X	X	X	XX		
	1	↑	1		D [17:0]								XX		
Set Tear Scanline	0	1	↑	XX	0	1	0	0	0	1	0	0	40h		
	1	1	↑	XX	X	X	X	X	X	X	X	STS [0]	00		
	1	1	↑	XX									STS [7:0]	00	
Get Scanline	0	1	↑	XX	0	1	0	0	0	1	0	1	45h		
	1	↑	1	XX	X	X	X	X	X	X	X	X	XX		
	1	↑	1	XX	X	X	X	X	X	X		GTS [9:0]	00		
	1	↑	1	XX									GTS [7:0]	00	
Write Display Brightness	0	1	↑	XX	0	1	0	1	0	0	0	1	51h		
	1	1	↑	XX									DBV [7:0]	00	

Read Display Brightness	0	1	↑	XX	0	1	0	1	0	0	1	0	52h
	1	↑	1	XX	X	X	X	X	X	X	X	X	XX
	1	↑	1	XX	DBV [7:0]								00
Write CTRL Display	0	1	↑	XX	0	1	0	1	0	0	1	1	53h
	1	↑	1	XX	X	X	BCTRL	X	DD	BL	X	X	00
	1	↑	1	XX	X	X	BCTRL	X	DD	BL	X	X	00
Read CTRL Display	0	1	↑	XX	0	1	0	1	0	1	0	0	54h
	1	↑	1	XX	X	X	X	X	X	X	X	X	XX
	1	↑	1	XX	X	X	BCTRL	X	DD	BL	X	X	00
Write Content Adaptive Brightness Control	0	1	↑	XX	0	1	0	1	0	1	0	1	55h
	1	↑	1	XX	X	X	X	X	X	X	C [1:0]		00
	1	↑	1	XX	X	X	X	X	X	X	X	X	XX
Read Content Adaptive Brightness Control	0	1	↑	XX	0	1	0	1	0	1	1	0	56h
	1	↑	1	XX	X	X	X	X	X	X	X	X	XX
	1	↑	1	XX	X	X	X	X	X	X	C [1:0]		00
Write CABC Minimum Brightness	0	1	↑	XX	0	1	0	1	1	1	1	0	5Eh
	1	↑	1	XX	CMB [7:0]								00
	1	↑	1	XX	X	X	X	X	X	X	X	X	XX
Read CABC Minimum Brightness	0	1	↑	XX	0	1	0	1	0	1	1	1	5Th
	1	↑	1	XX	X	X	X	X	X	X	X	X	XX
	1	↑	1	XX	CMB [7:0]								00
Read ID1	0	1	↑	XX	1	1	0	1	1	0	1	0	DAh
	1	↑	1	XX	X	X	X	X	X	X	X	X	XX
	1	↑	1	XX	Module's Manufacture [7:0]								XX
Read ID2	0	1	↑	XX	1	1	0	1	1	0	1	1	DBh
	1	↑	1	XX	X	X	X	X	X	X	X	X	XX
	1	↑	1	XX	LCD Module / Driver Version [7:0]								XX
Read ID3	0	1	↑	XX	1	1	0	1	1	1	0	0	DCh
	1	↑	1	XX	X	X	X	X	X	X	X	X	XX
	1	↑	1	XX	LCD Module / Driver ID [7:0]								XX

Extended Command Set													
Command Function	D/CX	RDX	WRX	D17-8	D7	D6	D5	D4	D3	D2	D1	D0	Hex
RGB Interface Signal Control	0	1	↑	XX	1	0	1	1	0	0	0	0	60h
	1	↑	1	XX	Bypass Mode	RCM [1:0]		X	VSP/L	HSPL	DPL	EPL	40
Frame Control (In Normal Mode)	0	1	↑	XX	1	0	1	1	0	0	0	1	61h
	1	↑	1	XX	X	X	X	X	X	X	DIVA [1:0]		00
	1	↑	1	XX	X	X	X	RTNA [4:0]				1B	
Frame Control (In Idle Mode)	0	1	↑	XX	1	0	1	1	0	0	1	0	62h
	1	↑	1	XX	X	X	X	X	X	X	DIVB [1:0]		00
	1	↑	1	XX	X	X	X	RTNB [4:0]				1B	
Frame Control (In Partial Mode)	0	1	↑	XX	1	0	1	1	0	0	1	1	63h
	1	↑	1	XX	X	X	X	X	X	X	DIVC [1:0]		00
	1	↑	1	XX	X	X	X	RINC [4:0]				1B	
Display Inversion Control	0	1	↑	XX	1	0	1	1	0	1	0	0	64h
	1	↑	1	XX	X	X	X	X	X	NLA	NLB	NLC	02
Blanking Porch Control	0	1	↑	XX	1	0	1	1	0	1	0	1	65h
	1	↑	1	XX	0	VBI* [6:0]							02
	1	↑	1	XX	0	VBI* [6:0]							02
	1	↑	1	XX	0	0	0	HBI* [4:0]				0A	
1	↑	1	XX	0	0	0	HBI* [4:0]				14		

Display Function Control	0	1	↑	XX	1	0	1	1	0	1	1	0	B6h	
	1	1	↑	XX	X	X	X	X	PIG [1:0]		PI [1:0]		0A	
	1	1	↑	XX	REV	GS	SS	SM	ISC [3:0]				62	
	1	1	↑	XX	X	X	NL [5:0]						27	
	1	1	↑	XX	X	X	PCDIV [5:0]						XX	
Entry Mode Set	0	1	↑	XX	1	0	1	1	0	1	1	1	07h	
	1	1	↑	XX	X	X	X	X	DSTB	CON	DTE	GAS	07	
Backlight Control 1	0	1	↑	XX	1	0	1	1	1	0	0	0	08h	
	1	1	↑	XX	X	X	X	X	X	X	X	X	XX	
	1	1	↑	XX	X	X	X	X	III_UI [3:0]				04	
Backlight Control 2	0	1	↑	XX	1	0	1	1	1	0	0	1	B9h	
	1	1	↑	XX	X	X	X	X	X	X	X	X	XX	
	1	1	↑	XX	TH_MV [3:0]				TH_ST [3:0]				68	
Backlight Control 3	0	1	↑	XX	1	0	1	1	1	0	1	0	0Ah	
	1	1	↑	XX	X	X	X	X	X	X	X	X	XX	
	1	1	↑	XX	X	X	X	X	DIII_UI [3:0]				04	
Backlight Control 4	0	1	↑	XX	1	0	1	1	1	0	1	1	BBh	
	1	1	↑	XX	X	X	X	X	X	X	X	X	XX	
	1	1	↑	XX	DTH_MV [3:0]				DTH_ST [3:0]				C9	
Backlight Control 5	0	1	↑	XX	1	0	1	1	1	1	0	0	BCb	
	1	1	↑	XX	X	X	X	X	X	X	X	X	XX	
	1	1	↑	XX	DIM2 [3:0]				X	DIM1 [2:0]			44	
Backlight Control 7	0	1	↑	XX	1	0	1	1	1	1	1	0	BFb	
	1	1	↑	XX	PWM_DIV [2:0]						UF			
	0	1	↑	XX	1	0	1	1	1	1	1	1	BFb	
Backlight Control 8	1	1	↑	XX	X	X	X	X	X	LEDONR	LEDONPOL	LEDPWMOP	00	
	0	1	↑	XX	1	1	0	0	0	0	0	0	00h	
Power Control 1	1	1	↑	XX	X	X	VRI [5:0]						26	
	0	1	↑	XX	1	1	0	0	0	0	0	1	01h	
Power Control 2	1	1	↑	XX	X	X	X	X	X	U1 [2:0]			00	
	0	1	↑	XX	1	1	0	0	0	1	0	1	05h	
VCOM Control 1	1	1	↑	XX	X	VM1 [6:0]						31		
	1	1	↑	XX	X	VM [6:0]						3C		
	0	1	↑	XX	1	1	0	0	0	1	1	1	07h	
VCOM Control 2	1	1	↑	XX	nVM	VMΓ [6:0]						C0		
	0	1	↑	XX	1	1	0	1	0	0	0	0	D0h	
NV Memory Write	1	1	↑	XX	X	X	X	X	X	PGM_ADR [2:0]			00	
	1	1	↑	XX	PGM_DATA [7:0]							XX		
	0	1	↑	XX	1	1	0	1	0	0	0	1	D1h	
NV Memory Protection Key	1	1	↑	XX	KEY [23:16]								55	
	1	1	↑	XX	KEY [15:8]								AA	
	1	1	↑	XX	KEY [7:0]								66	
NV Memory Status Read	0	1	↑	XX	1	1	0	1	0	0	1	0	D2h	
	1	↑	1	XX	X	X	X	X	X	X	X	X	XX	
	1	↑	1	XX	X	ID2_CNT [2:0]			X	ID1_CNT [2:0]			XX	
	1	↑	1	XX	BUSY	VMF_CNT [2:0]		X	ID3_CNT [2:0]			XX		

Read ID	0	-	1	XX	1	1	0	1	0	0	1	1	D3h	
	1	-	1	XX	X	X	X	X	X	X	X	X	XX	
	1	-	1	XX	0	0	0	0	0	0	0	0	00	
	1	-	1	XX	1	0	0	1	0	0	1	1	93	
	1	-	1	XX	0	1	0	0	0	0	0	1	11	
Positive Gamma Correction	0	1	↑	XX	1	1	1	0	0	0	0	0	E0h	
	1	1	↑	XX	X	X	X	X	VP0 [3:0]				08	
	1	1	↑	XX	X	X	VP1 [5:0]						0F	
	1	1	↑	XX	X	X	VP2 [5:0]						12	
	1	1	↑	XX	X	X	X	X	VP4 [3:0]				05	
	1	1	↑	XX	X	X	VP6 [4:0]						03	
	1	1	↑	XX	X	X	X	X	VP13 [3:0]				09	
	1	1	↑	XX	X	VP20 [6:0]						47		
	1	1	↑	XX	VP36 [3:0]			VP27 [3:0]					86	
	1	1	↑	XX	X	VP43 [6:0]						2R		
	1	1	↑	XX	X	X	X	X	VP50 [3:0]				0B	
	1	1	↑	XX	X	X	VP57 [4:0]						01	
	1	1	↑	XX	X	X	X	X	VP59 [3:0]				00	
	1	1	↑	XX	X	X	VP61 [5:0]						00	
	1	1	↑	XX	X	X	VP62 [5:0]						00	
	1	1	↑	XX	X	X	X	X	VP63 [3:0]				00	
	Negative Gamma Correction	0	1	↑	XX	1	1	1	0	0	0	0	1	E11i
1		1	↑	XX	X	X	X	X	VN0 [3:0]				00	
1		1	↑	XX	X	X	VN1 [5:0]						1A	
1		1	↑	XX	X	X	VN2 [5:0]						20	
1		1	↑	XX	X	X	X	X	VN4 [3:0]				07	
1		1	↑	XX	X	X	VN6 [4:0]						0F	
1		1	↑	XX	X	X	X	X	VN13 [3:0]				05	
1		1	↑	XX	X	VN20 [6:0]						3A		
1		1	↑	XX	VN36 [3:0]			VN27 [3:0]					9A	
1		1	↑	XX	X	VN43 [6:0]						40		
1		1	↑	XX	X	X	X	X	VN50 [3:0]				04	
1		1	↑	XX	X	X	VN57 [4:0]						16	
1		1	↑	XX	X	X	X	X	VN59 [3:0]				07	
1		1	↑	XX	X	X	VN61 [5:0]						3F	
1	1	↑	XX	X	X	VN62 [5:0]						3F		
1	1	↑	XX	X	X	X	X	VN63 [3:0]				0F		
Digital Gamma Control 1	0	1	↑	XX	1	1	1	0	0	0	1	0	E2h	
1 st Parameter	1	1	↑	XX	RCA0 [3:0]						RCA0 [3:0]			XX
-	1	1	↑	XX	RCAx [3:0]						RCAx [3:0]			XX
16 th Parameter	1	1	↑	XX	RCA15 [3:0]						RCA15 [3:0]			XX
Digital Gamma Control 2	0	1	↑	XX	1	1	1	0	0	0	1	1	E3h	
1 st Parameter	1	1	↑	XX	RFA0 [3:0]						RFA0 [3:0]			XX
-	1	1	↑	XX	RFAx [3:0]						RFAx [3:0]			XX
64 th Parameter	1	1	↑	XX	RFA63 [3:0]						RFA63 [3:0]			XX
Interface Control	0	1	↑	XX	1	1	1	1	0	1	1	0	F6h	
	1	1	↑	XX	mv_por	mx_por	mv_por	X	ncs_por	X	X	wfmodr	01	
	1	1	↑	XX	X	X	LPH [1:0]		X	X	MDI [1:0]		00	
	1	1	↑	XX	X	X	FNMAN	X	DM [1:0]	RM	RIM	00		

Note 1: Undefined commands are treated as NOP (00h) command.

Note 2: B0 to D9 and DE to FF are for factory use of display supplier. USER can decide if these commands are available or they are treated as NOP (00h) commands before shipping to USER. Default value is NOP (00h).

Note 3: Commands 10h, 12h, 13h, 26h, 28h, 29h, 30h, 36h (Bit B4 only), 38h and 39h are updated during V-SYNC when ILI9340C is in Sleep OUT mode to avoid abnormal visual effects. During Sleep IN mode, these commands are updated immediately. Read status (09h), Read display power mode (0Ah), Read display MADCTL (0Bh), Read display pixel format (0Ch), Read display image mode (0Dh), Read display signal mode (0Eh) and Read display self diagnostic result (0Fh) of these commands are updated immediately both in Sleep IN mode and Sleep OUT mode.

12. Quality Assurance

12.1. Purpose

This standard for Quality Assurance assures the quality of LCD module products supplied to customer.

12.2. Standard for Quality Test

12.2.1 Sampling Plan:

ANSI / ASQC Z1.4-1993.

Single sampling, normal inspection.

12.2.2 Sampling Criteria:

Visual inspection: AQL 1.5%

Electrical functional: AQL 0.65%.

12.2.3 Reliability Test:

Detailed requirement refer to Reliability Test Specification.

12.3. Nonconforming Analysis & Disposition

12.3.1 Nonconforming analysis:

12.3.1.1 Customer should provide overall information of non-conforming sample for their complaints.

12.3.1.2 After receipt of detailed information from customer, the analysis of nonconforming parts usually should be finished in one week.

12.3.1.3 If cannot finish the analysis on time, customer will be notified with the progress status.

12.3.2 Disposition of nonconforming:

12.3.2.1 Non-conforming product over PPM level will be replaced.

12.3.2.2 The cause of non-conformance will be analyzed. Corrective action will be discussed and implemented.

12.4. Agreement Items

Shall negotiate with customer if the following situation occurs:

12.4.1 There is any discrepancy in standard of quality assurance.

12.4.2 Additional requirement to be added in product specification.

12.4.3 Any other special problem.

12.5. Standard of the Product Visual Inspection

12.5.1 Appearance inspection:

12.5.1.1 The inspection must be under illumination about 1000 – 1500 lx, and the distance of view must be at 30cm ± 2cm.

12.5.1.2 The viewing angle should be 45° from the vertical line without reflection light or follows customer's viewing angle specifications.

12.5.1.3 Definition of area: A Zone: Active Area, B Zone: Viewing Area,

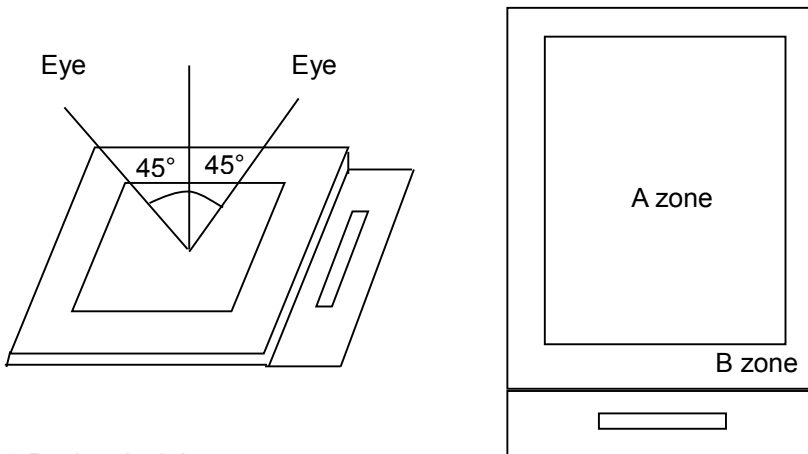

12.5.2 Basic principle:

12.5.2.1 A set of sample to indicate the limit of acceptable quality level must be discussed by both us and customer when there is any dispute happened.

12.5.2.2 New item must be added on time when it is necessary.

12.6. Inspection Specification

No.	Item	Criteria (Unit: mm)																
01	Black / White spot Foreign material (Round type) Pinholes Stain Particles inside cell. (Minor defect)	<p>$\phi = (a + b) / 2$</p>																
		<table border="1"> <thead> <tr> <th>Size</th> <th>Area</th> <th>Acc. Qty</th> </tr> </thead> <tbody> <tr> <td>$\phi \leq 0.10$</td> <td></td> <td>Ignore</td> </tr> <tr> <td>$0.10 < \phi \leq 0.15$</td> <td></td> <td>2</td> </tr> <tr> <td>$0.15 < \phi \leq 0.25$</td> <td></td> <td>1</td> </tr> <tr> <td>$0.25 < \phi$</td> <td></td> <td>0</td> </tr> <tr> <td>Total</td> <td></td> <td>2 no include $\phi \leq 0.10$</td> </tr> </tbody> </table>	Size	Area	Acc. Qty	$\phi \leq 0.10$		Ignore	$0.10 < \phi \leq 0.15$		2	$0.15 < \phi \leq 0.25$		1	$0.25 < \phi$		0	Total
Size	Area	Acc. Qty																
$\phi \leq 0.10$		Ignore																
$0.10 < \phi \leq 0.15$		2																
$0.15 < \phi \leq 0.25$		1																
$0.25 < \phi$		0																
Total		2 no include $\phi \leq 0.10$																
Distance between 2 defects should more than 3mm apart.																		

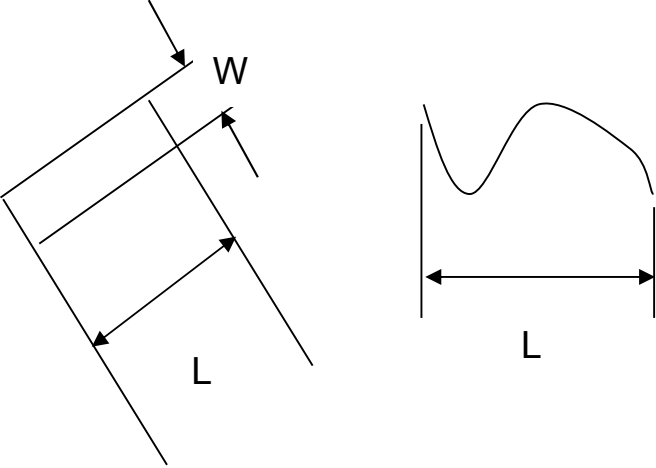
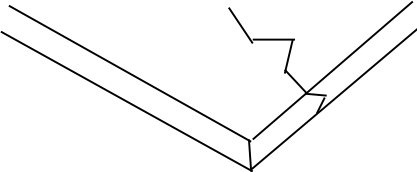
<p>02</p>	<p>Black and White line Scratch Foreign material (Line type) (Minor defect)</p>	 <table border="1" data-bbox="614 804 1240 1113"> <thead> <tr> <th>Length</th> <th>Width</th> <th>Acc. Qty</th> </tr> </thead> <tbody> <tr> <td>/</td> <td>$W \leq 0.03$</td> <td>Ignore</td> </tr> <tr> <td>$L \leq 2.5$</td> <td>$0.03 < W \leq 0.05$</td> <td>3</td> </tr> <tr> <td>$L \leq 2.5$</td> <td>$0.05 < W \leq 0.10$</td> <td>2</td> </tr> <tr> <td>/</td> <td>$0.1 < W$</td> <td>0</td> </tr> <tr> <td colspan="2">Total</td> <td>3</td> </tr> </tbody> </table> <p>Distance between 2 defects should more than 3mm apart. Scratches not viewable through the back of the display are acceptable.</p>	Length	Width	Acc. Qty	/	$W \leq 0.03$	Ignore	$L \leq 2.5$	$0.03 < W \leq 0.05$	3	$L \leq 2.5$	$0.05 < W \leq 0.10$	2	/	$0.1 < W$	0	Total		3
Length	Width	Acc. Qty																		
/	$W \leq 0.03$	Ignore																		
$L \leq 2.5$	$0.03 < W \leq 0.05$	3																		
$L \leq 2.5$	$0.05 < W \leq 0.10$	2																		
/	$0.1 < W$	0																		
Total		3																		
<p>03</p>	<p>Glass Crack (Minor defect)</p>	 <p>Crack is potential to enlarge, any type is not allowed.</p>																		

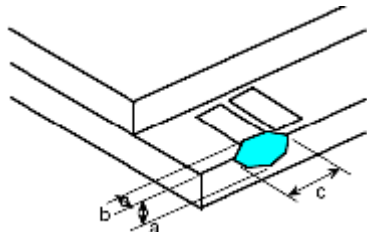
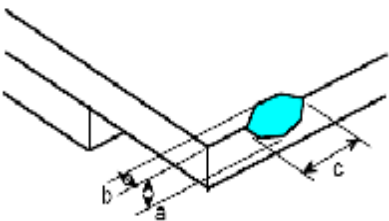
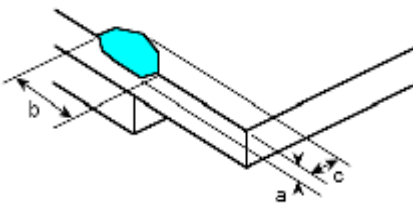
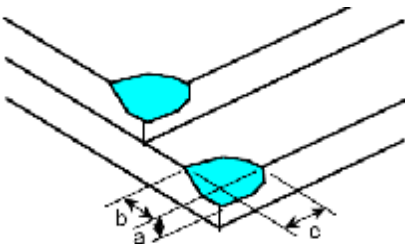
<p>04</p>	<p>Glass Chipping Pad Area: (Minor defect)</p> 	<table border="1"> <thead> <tr> <th>Length and Width</th> <th>Acc. Qty</th> </tr> </thead> <tbody> <tr> <td>$c > 3.0, b < 1.0$</td> <td>1</td> </tr> <tr> <td>$c < 3.0, b < 1.0$</td> <td>3</td> </tr> <tr> <td colspan="2" style="text-align: center;">$a < \text{Glass Thickness}$</td> </tr> </tbody> </table>	Length and Width	Acc. Qty	$c > 3.0, b < 1.0$	1	$c < 3.0, b < 1.0$	3	$a < \text{Glass Thickness}$			
Length and Width	Acc. Qty											
$c > 3.0, b < 1.0$	1											
$c < 3.0, b < 1.0$	3											
$a < \text{Glass Thickness}$												
<p>05</p>	<p>Glass Chipping Rear of Pad Area: (Minor defect)</p> 	<table border="1"> <thead> <tr> <th>Length and Width</th> <th>Acc. Qty</th> </tr> </thead> <tbody> <tr> <td>$c > 3.0, b < 1.0$</td> <td>1</td> </tr> <tr> <td>$c < 3.0, b < 1.0$</td> <td>2</td> </tr> <tr> <td>$c < 3.0, b < 0.5$</td> <td>4</td> </tr> <tr> <td colspan="2" style="text-align: center;">$a < \text{Glass Thickness}$</td> </tr> </tbody> </table>	Length and Width	Acc. Qty	$c > 3.0, b < 1.0$	1	$c < 3.0, b < 1.0$	2	$c < 3.0, b < 0.5$	4	$a < \text{Glass Thickness}$	
Length and Width	Acc. Qty											
$c > 3.0, b < 1.0$	1											
$c < 3.0, b < 1.0$	2											
$c < 3.0, b < 0.5$	4											
$a < \text{Glass Thickness}$												
<p>06</p>	<p>Glass Chipping Except Pad Area: (Minor defect)</p> 	<table border="1"> <thead> <tr> <th>Length and Width</th> <th>Acc. Qty</th> </tr> </thead> <tbody> <tr> <td>$c > 3.0, b < 1.0$</td> <td>1</td> </tr> <tr> <td>$c < 3.0, b < 1.0$</td> <td>2</td> </tr> <tr> <td>$c < 3.0, b < 0.5$</td> <td>4</td> </tr> <tr> <td colspan="2" style="text-align: center;">$a < \text{Glass Thickness}$</td> </tr> </tbody> </table>	Length and Width	Acc. Qty	$c > 3.0, b < 1.0$	1	$c < 3.0, b < 1.0$	2	$c < 3.0, b < 0.5$	4	$a < \text{Glass Thickness}$	
Length and Width	Acc. Qty											
$c > 3.0, b < 1.0$	1											
$c < 3.0, b < 1.0$	2											
$c < 3.0, b < 0.5$	4											
$a < \text{Glass Thickness}$												
<p>07</p>	<p>Glass Corner Chipping: (Minor defect)</p> 	<table border="1"> <thead> <tr> <th>Length and Width</th> <th>Acc. Qty</th> </tr> </thead> <tbody> <tr> <td>$c < 3.0, b < 3.0$</td> <td>Ignore</td> </tr> <tr> <td colspan="2" style="text-align: center;">$a < \text{Glass Thickness}$</td> </tr> </tbody> </table>	Length and Width	Acc. Qty	$c < 3.0, b < 3.0$	Ignore	$a < \text{Glass Thickness}$					
Length and Width	Acc. Qty											
$c < 3.0, b < 3.0$	Ignore											
$a < \text{Glass Thickness}$												

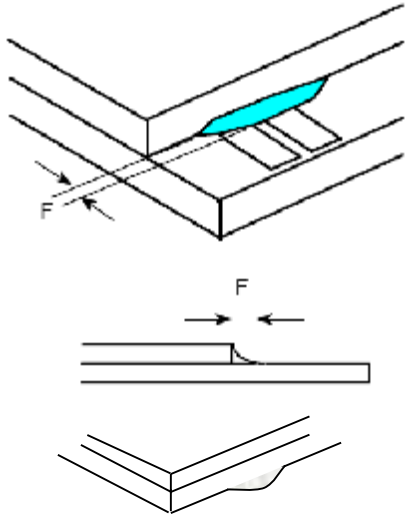
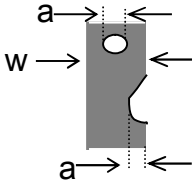
<p>08</p>	<p>Glass Burr: (Minor defect)</p> 	<table border="1" data-bbox="866 264 1339 351"> <tr> <th>Length</th> <th>Acc. Qty</th> </tr> <tr> <td>$F < 1.0$</td> <td>Ignore</td> </tr> </table> <p>Glass burr don't affect assemble and module dimension.</p>	Length	Acc. Qty	$F < 1.0$	Ignore				
Length	Acc. Qty									
$F < 1.0$	Ignore									
<p>09</p>	<p>FPC Defect: (Minor defect)</p> 	<p>9.1 Dent, pinhole width $a < w/3$. (w: circuitry width.) 9.2 Open circuit is unacceptable. 9.3 No oxidation, contamination and distortion.</p>								
<p>10</p>	<p>Bubble on Polarizer (Minor defect)</p>	<table border="1" data-bbox="743 1379 1214 1552"> <tr> <th>Diameter</th> <th>Acc. Qty</th> </tr> <tr> <td>$\varphi \leq 0.20$</td> <td>Ignore</td> </tr> <tr> <td>$0.20 < \varphi \leq 0.30$</td> <td>4</td> </tr> <tr> <td>$0.30 < \varphi$</td> <td>None</td> </tr> </table>	Diameter	Acc. Qty	$\varphi \leq 0.20$	Ignore	$0.20 < \varphi \leq 0.30$	4	$0.30 < \varphi$	None
Diameter	Acc. Qty									
$\varphi \leq 0.20$	Ignore									
$0.20 < \varphi \leq 0.30$	4									
$0.30 < \varphi$	None									
<p>11</p>	<p>Dent on Polarizer (Minor defect)</p>	<table border="1" data-bbox="743 1621 1214 1794"> <tr> <th>Diameter</th> <th>Acc. Qty</th> </tr> <tr> <td>$\varphi \leq 0.20$</td> <td>Ignore</td> </tr> <tr> <td>$0.20 < \varphi \leq 0.30$</td> <td>4</td> </tr> <tr> <td>$0.30 < \varphi$</td> <td>None</td> </tr> </table>	Diameter	Acc. Qty	$\varphi \leq 0.20$	Ignore	$0.20 < \varphi \leq 0.30$	4	$0.30 < \varphi$	None
Diameter	Acc. Qty									
$\varphi \leq 0.20$	Ignore									
$0.20 < \varphi \leq 0.30$	4									
$0.30 < \varphi$	None									
<p>12</p>	<p>Bezel</p>	<p>12.1 No rust, distortion on the Bezel. 12.2 No visible fingerprints, stains or other contamination.</p>								

13	Touch Panel	<p>D: Diameter W: width L: length</p> <p>13.1 Spot: $D < 0.25$ is acceptable $0.25 \leq D \leq 0.4$</p> <p>2dots are acceptable and the distance between defects should more than 10 mm.</p> <p>$D > 0.4$ is unacceptable</p> <p>13.2 Dent: $D > 0.40$ is unacceptable</p> <p>13.3 Scratch: $W \leq 0.03$, $L \leq 10$ is acceptable, $0.03 < W \leq 0.10$, $L \leq 10$ is acceptable</p> <p>Distance between 2 defects should more than 10 mm. $W > 0.10$ is unacceptable.</p>
14	PCB	<p>14.1 No distortion or contamination on PCB terminals.</p> <p>14.2 All components on PCB must same as documented on the BOM/component layout.</p> <p>14.3 Follow IPC-A-600F.</p>
15	Soldering	Follow IPC-A-610C standard
16	Electrical Defect (Major defect)	<p>The below defects must be rejected.</p> <p>16.1 Missing vertical / horizontal segment,</p> <p>16.2 Abnormal Display.</p> <p>16.3 No function or no display.</p> <p>16.4 Current exceeds product specifications.</p> <p>16.5 LCD viewing angle defect.</p> <p>16.6 No Backlight.</p> <p>16.7 Dark Backlight.</p> <p>16.8 Touch Panel no function.</p> <p>16.9 Dark Dot –one Allowed.</p> <p>16.10 Bright Dot – one Allowed.</p> <p>Remark:</p> <p>1. A pixel defect is acceptable if one color is none functional and causes a bright dot. The display may have one case where one color is out and cause a dark dot.</p> <p>2. Bright dot caused by scratch and foreign object accords to item 1.</p>

Remark: LCD Panel Broken shall be rejected. Defect out of LCD viewing area is acceptable.

12.7. Classification of Defects

12.7.1 Visual defects (Except no / wrong label) are treated as minor defect and electrical defect is major.

12.7.2 Two minor defects are equal to one major in lot sampling inspection.

12.8. Identification/marketing criteria

Any unit with illegible / wrong /double or no marking/ label shall be rejected.

12.9. Packing

12.9.1 There should be no damage of the outside carton box, each packaging box should have one identical label.

12.9.2 Modules inside package box should have compliant mark.

12.9.3 All direct package materials shall offer ESD protection

13. Reliability Specification

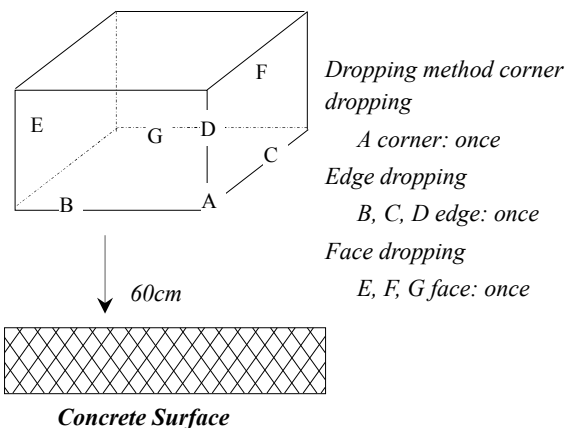
No	Item	Condition	Quantity
1	High Temperature Operating	70°C, 96Hrs	5
2	Low Temperature Operating	-20°C, 96Hrs	5
3	High Humidity	50°C, 90%RH, 96Hrs	5
4	High Temperature Storage	80°C, 96Hrs	5
5	Low Temperature Storage	-30°C, 96Hrs	5
6	Thermal shock	-20°C, 30min~70°C, 30min, 10 cycles.	5
7	Packing vibration	Frequency range: 10Hz~55Hz Amplitude of vibration: 1.5mm Sweep time: 12min X, Y, Z 2 hours for each direction.	5
8	Electrical Static Discharge	Air: ±4KV 150pF/330Ω 5 times	5
		Contact: ±2KV 150pF/330Ω 5 times	
9	Drop Test	<p>To be measured after dropping from 60cm high on the concrete surface in packing state.</p>  <p><i>Dropping method corner dropping</i> <i>A corner: once</i> <i>Edge dropping</i> <i>B, C, D edge: once</i> <i>Face dropping</i> <i>E, F, G face: once</i></p> <p>Concrete Surface</p>	5

Note1. No deflection cosmetic and operational function allowable.

Note2. Total current Consumption should be below double of initial value

14. Packaging

t.b.d.

15. Outline Drawing

