

THIS DRAWING IS UNPUBLISHED. RELEASED FOR PUBLICATION 20
 © COPYRIGHT 20 BY - ALL RIGHTS RESERVED.

LOC	DIST	REVISIONS					
ES	00	P	LTR	DESCRIPTION	DATE	DWN	APVD
		B3		REVISED PER ECR-15-013268	10SEP2015	NK	GJ

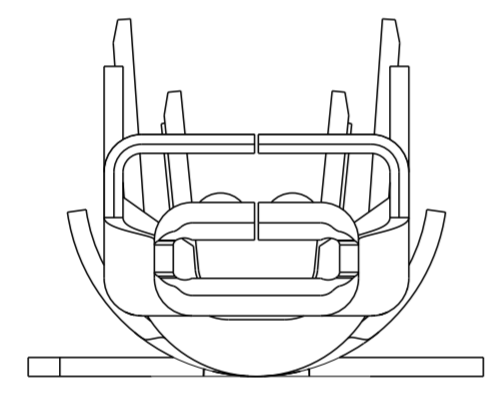

SCALE 10:1

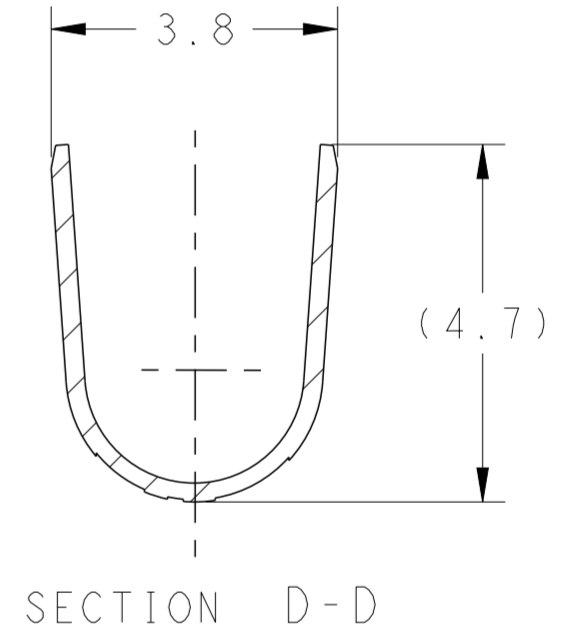
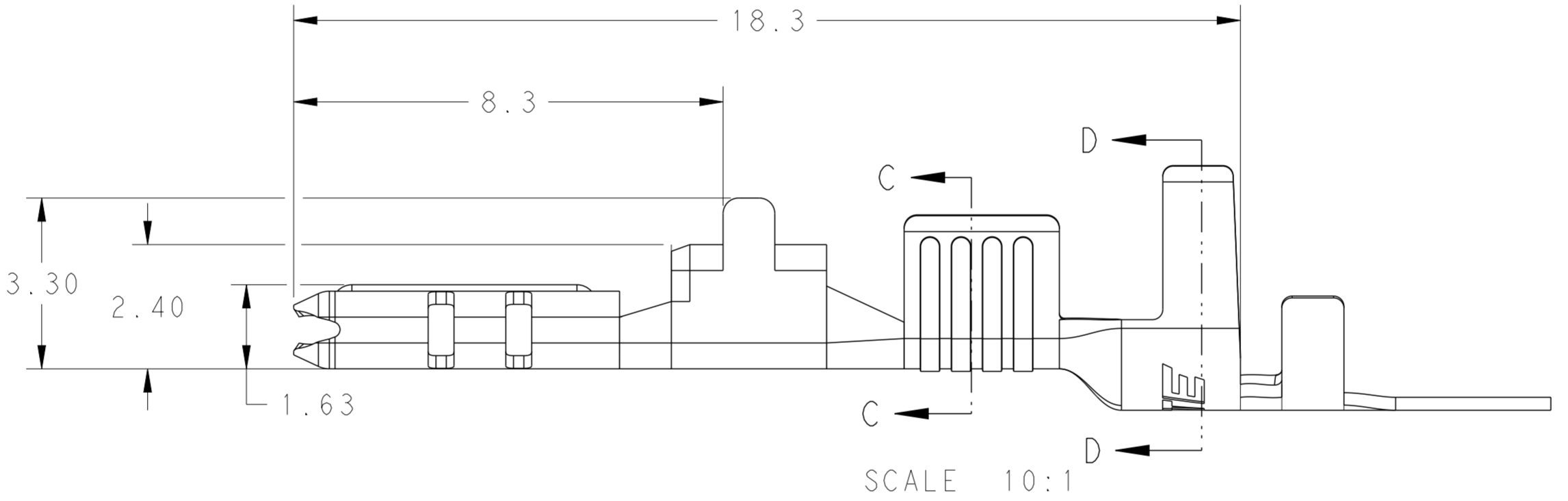
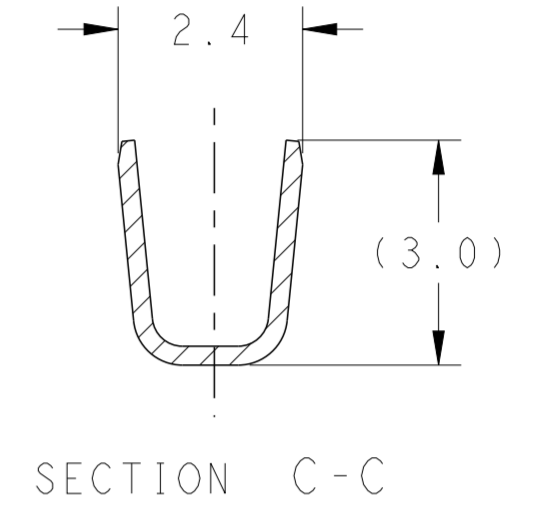
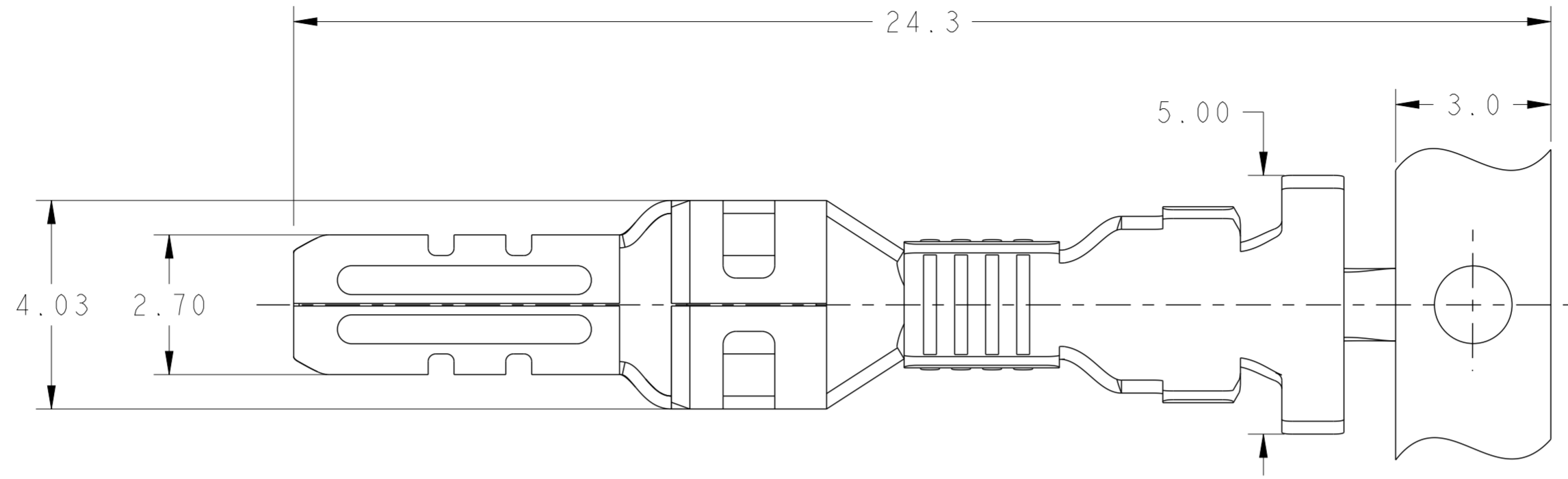
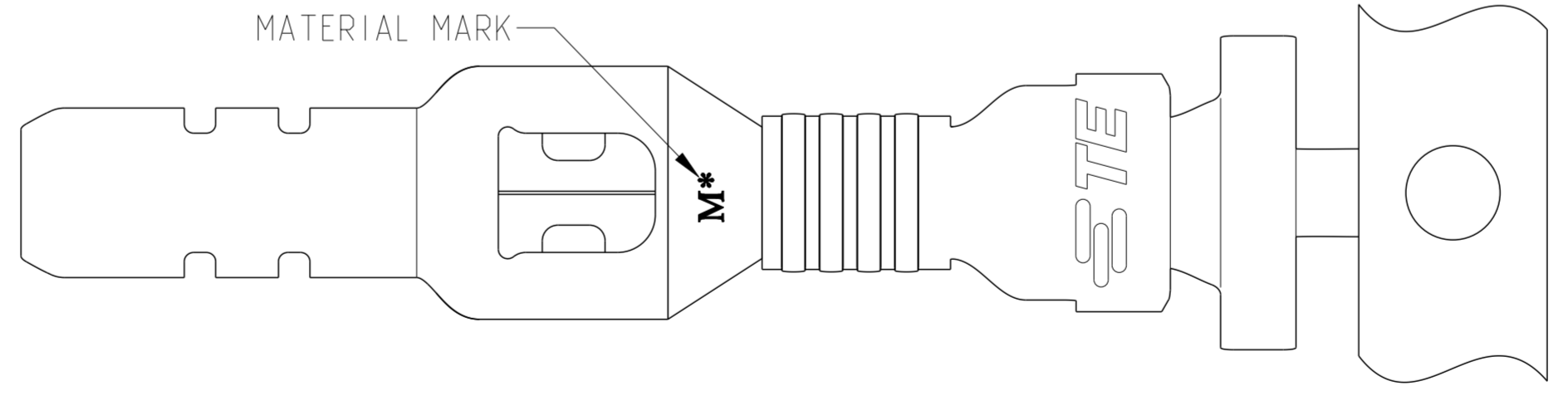

- 1 APPLICABLE WIRE RANGE: 16~20AWG COPPER STRANDED OR 2x22 AWG COPPER STRANDED . FOR A #20 AWG WIRE THE RECOMMENDED MINIMUM CROSS-SECTIONAL AREA IS 0.65mm² (1300 CMA).
- 2 FOR #20 AWG WIRE WITH AN AREA/CMA SMALLER THAN INDICATED ABOVE, TAB 1971786-() IS RECOMMENDED.
- 3 APPLICABLE INSULATION DIAMETER: 2.40~3.30mm. 2.00~3.30 mm (2.0 mm MAX FOR 2x22 AWG) WHEN OVERLAP INSULATION APPLICATOR USED.
- 4 APPLICABLE MATED CAP HOUSING P/N:
 -1971771-/*-1971774-*/*-1971874-*
 -1971772-/*-1971775-*/*-1971875-*
 -2232263-/*-2232264-*/*-2232356-*
 -2232358-/*-2232359-*/*-2232360-*

5 This product has not completed validation testing.

COPPER ALLOY	HIGH(150°C)	M0	1971784-2
BRASS	STANDARD(105°C)	M8	1971784-1
MATERIAL	TEMP. RATING	MATERIAL MARK	PART NO

THIS DRAWING IS A CONTROLLED DOCUMENT.		DWN TOMMY WU 11JUL2011	STE TE Connectivity	
DIMENSIONS: mm		CHK HAPYE WU 11JUL2011		
TOLERANCES UNLESS OTHERWISE SPECIFIED:		APVD YUHONG MAO 11JUL2011	NAME	
0 PLC ±		PRODUCT SPEC	TAB CONTACT POWER TRIPLE LOCK	
1 PLC ±0.5		APPLICATION SPEC	-	
2 PLC ±0.30		108-106118	SIZE	CAGE CODE
3 PLC ±		114-106118	A2	00779
4 PLC ±		WEIGHT	DRAWING NO	RESTRICTED TO
ANGLES ±		-	G-1971784	-
FINISH		Customer Drawing	SCALE	SHEET 1 OF 1
SEE TABLE		PRE-TIN		REV B3