

Type 2 surge arrester - VAL-EV-T2 280/3+1



1180144

<https://www.phoenixcontact.com/gb/products/1180144>

Please be informed that the data shown in this PDF document is generated from our Online Catalog. Please find the complete data in the user documentation. Our General Terms of Use for Downloads are valid.



CHARX protect: pluggable surge protective device, in accordance with Type 2 / Class II, for 3-phase power supply networks with separate N and PE (5-conductor system: L1, L2, L3, N, PE). Specifically designed for use in e-mobility.

Your advantages

- Uninterrupted continuation of the charging process with a protected power supply
- Additional protection for the connected electric vehicle
- High system availability, thanks to a high-performance protective circuit
- Easy insulation measurement and simple replacement during servicing with consistently pluggable protective devices
- No mismatching of plugs, thanks to mechanical coding

Commercial Data

Item number	1180144
Packing unit	1 pc
Minimum order quantity	1 pc
Note	Made to Order (non-returnable)
Sales Key	CL1321
Product Key	CL1321
GTIN	4063151215521
Weight per Piece (including packing)	406.4 g
Weight per Piece (excluding packing)	386.115 g
Customs tariff number	85363030
Country of origin	DE

Type 2 surge arrester - VAL-EV-T2 280/3+1

1180144

<https://www.phoenixcontact.com/gb/products/1180144>

Technical Data

Product properties

IEC test classification	II
	T2
EN type	T2
IEC power supply system	TN-S
	TT
Type	DIN rail module, two-section, divisible
Product type	Arrester combination
Number of positions	4
Surge protection fault message	optical

Insulation characteristics

Overvoltage category	III
Pollution degree	2

Electrical properties

Nominal frequency f_N	50 Hz (60 Hz)
-------------------------	---------------

Connection data

Connection method	Screw connection
Screw thread	M5
Tightening torque	3 Nm (1.5 mm ² ... 16 mm ²)
	4.5 Nm (25 mm ² ... 35 mm ²)
Stripping length	16 mm
Conductor cross section flexible	1.5 mm ² ... 25 mm ²
Conductor cross section solid	1.5 mm ² ... 35 mm ²
Conductor cross section AWG	15 ... 2
Connection method	Fork-type cable lug
Conductor cross section flexible	1.5 mm ² ... 16 mm ²

Dimensions

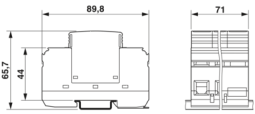
Dimensional drawing	
Width	71 mm
Height	89.8 mm
Depth	65.7 mm (incl. DIN rail 7.5 mm)
Horizontal pitch	4 Div.

Material specifications

Type 2 surge arrester - VAL-EV-T2 280/3+1



1180144

<https://www.phoenixcontact.com/gb/products/1180144>

Color	light grey RAL 7035
Flammability rating according to UL 94	V-0
CTI value of material	600
Insulating material	PA 6.6/PBT
Material group	I
Housing material	PA 6.6
	PBT

Mechanical properties

Mechanical data

Open side panel	No
-----------------	----

Protective circuit

Mode of protection	L-N
	L-PE
	N-PE
Direction of action	3L-N & N-PE
Nominal voltage U_N	240/415 V AC (TN-S)
	240/415 V AC (TT)
Nominal frequency f_N	50 Hz (60 Hz)
Maximum continuous operating voltage U_C (L-N)	280 V AC
Maximum continuous operating voltage U_C (L-PE)	280 V AC
Maximum continuous operating voltage U_C (N-PE)	260 V AC
Rated load current I_L	80 A
Residual current I_{PE}	$\leq 5 \mu\text{A}$
Standby power consumption P_C	$\leq 450 \text{ mVA}$
Nominal discharge current I_n (8/20) μs	20 kA
Maximum discharge current I_{max} (8/20) μs	40 kA
Follow current interrupt rating I_{fi} (N-PE)	100 A
Short-circuit current rating I_{SCCR}	25 kA
Voltage protection level U_p (L-N)	$\leq 1.5 \text{ kV}$
Voltage protection level U_p (L-PE)	$\leq 1.9 \text{ kV}$
Voltage protection level U_p (N-PE)	$\leq 1.5 \text{ kV}$
Residual voltage U_{res} (L-N)	$\leq 1.5 \text{ kV}$ (at I_n)
	$\leq 1.3 \text{ kV}$ (at 10 kA)
	$\leq 1.2 \text{ kV}$ (at 5 kA)
	$\leq 1.1 \text{ kV}$ (at 3 kA)
Residual voltage U_{res} (L-PE)	$\leq 1.9 \text{ kV}$ (at I_n)
	$\leq 1.5 \text{ kV}$ (at 10 kA)
	$\leq 1.3 \text{ kV}$ (at 5 kA)
	$\leq 1.2 \text{ kV}$ (at 3 kA)
Residual voltage U_{res} (N-PE)	$\leq 0.4 \text{ kV}$ (at I_n)
	$\leq 0.25 \text{ kV}$ (at 10 kA)
	$\leq 0.15 \text{ kV}$ (at 5 kA)

Type 2 surge arrester - VAL-EV-T2 280/3+1



1180144

<https://www.phoenixcontact.com/gb/products/1180144>

	≤ 0.1 kV (at 3 kA)
TOV behavior at U_T (L-N)	415 V AC (5 s / withstand mode)
	440 V AC (120 min / safe failure mode)
TOV behavior at U_T (N-PE)	1200 V AC (200 ms / withstand mode)
Response time t_A (L-N)	≤ 25 ns
Response time t_A (L-PE)	≤ 100 ns
Response time t_A (N-PE)	≤ 100 ns
Max. backup fuse with V-type through wiring	80 A (gG)
Max. backup fuse with branch wiring	125 A (gG)

Environmental and real-life conditions

Ambient conditions

Degree of protection	IP20 (only when all terminal points are used)
Ambient temperature (operation)	-40 °C ... 80 °C
Ambient temperature (storage/transport)	-40 °C ... 80 °C
Altitude	≤ 2000 m (amsl (above mean sea level))
Permissible humidity (operation)	5 % ... 95 %
Shock (operation)	25g (Half-sine / 11 ms / 3x ±X, ±Y, ±Z)
Vibration (operation)	5g (10 ... 500 Hz / 2.5 h / X, Y, Z)

Standards and regulations

Standards/specifications	IEC 61643-11
Standards/specifications	EN 61643-11

Mounting

Mounting type	DIN rail: 35 mm
---------------	-----------------

Type 2 surge arrester - VAL-EV-T2 280/3+1

1180144

<https://www.phoenixcontact.com/gb/products/1180144>

Drawings

Circuit diagram

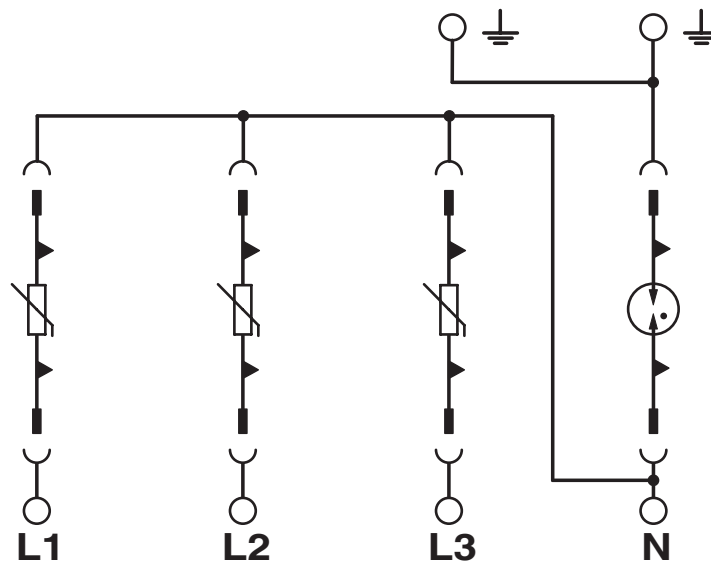

Dimensional drawing

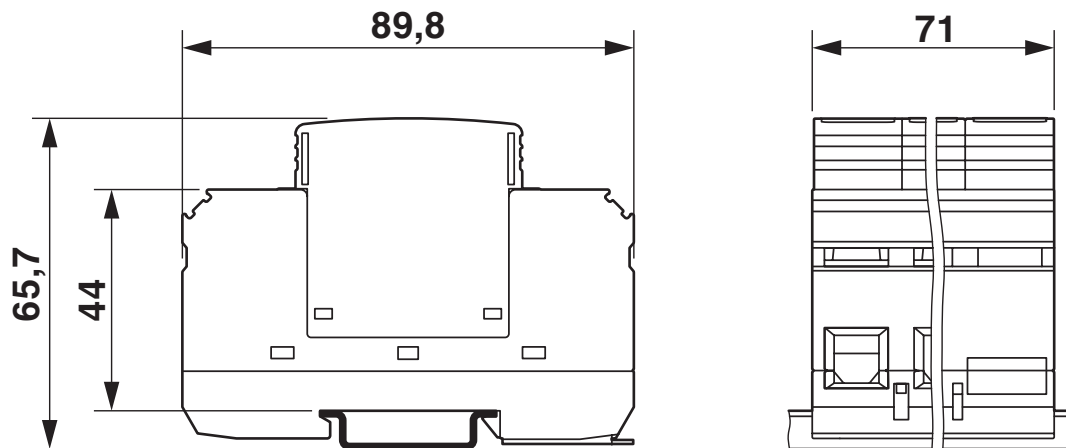

Type 2 surge arrester - VAL-EV-T2 280/3+1



1180144

<https://www.phoenixcontact.com/gb/products/1180144>

Approvals



KEMA-KEUR
Approval ID: 71-113416

Type 2 surge arrester - VAL-EV-T2 280/3+1



1180144

<https://www.phoenixcontact.com/gb/products/1180144>

Classifications

ECLASS

ECLASS-9.0	27130802
ECLASS-10.0.1	27130802
ECLASS-11.0	27130802

ETIM

ETIM 8.0	EC000381
----------	----------

UNSPSC

UNSPSC 21.0	39121600
-------------	----------

Type 2 surge arrester - VAL-EV-T2 280/3+1



1180144

<https://www.phoenixcontact.com/gb/products/1180144>

Environmental Product Compliance

China RoHS	Environmentally friendly use period: unlimited = EFUP-e
	No hazardous substances above threshold values

Type 2 surge arrester - VAL-EV-T2 280/3+1

1180144

<https://www.phoenixcontact.com/gb/products/1180144>

Accessories

Zack marker strip

Zack marker strip - ZBN 18:UNBEDRUCKT - 2809128

<https://www.phoenixcontact.com/gb/products/2809128>



Zack marker strip, Strip, white, unlabeled, can be labeled with: CMS-P1-PLOTTER, PLOTMARK, mounting type: snapped, for terminal block width: 18 mm, lettering field size: 18 x 5 mm, Number of individual labels: 5

Marker for terminal blocks

Marker for terminal blocks - ZBN 18,LGS:ERDE - 2749589

<https://www.phoenixcontact.com/gb/products/2749589>



Marker for terminal blocks, Strip, white, labeled, horizontal: Grounding symbol, mounting type: snapped, for terminal block width: 18 mm, lettering field size: 18 x 5 mm, Number of individual labels: 5

Type 2 surge arrester - VAL-EV-T2 280/3+1

1180144

<https://www.phoenixcontact.com/gb/products/1180144>

Marker for terminal blocks

Marker for terminal blocks - ZBN 18,LGS:L1-N,ERDE - 2749576

<https://www.phoenixcontact.com/gb/products/2749576>

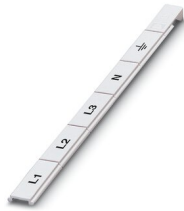

Marker for terminal blocks, Strip, white, labeled, horizontal: L1, L2, L3, N, GND, mounting type: snapped, for terminal block width: 18 mm, lettering field size: 18 x 5 mm, Number of individual labels: 5

Marker pen

Marker pen - B-STIFT - 1051993

<https://www.phoenixcontact.com/gb/products/1051993>



Marker pen, for manual labeling of unprinted Zack strips, smear-proof and waterproof, line thickness 0.5 mm

Type 2 surge arrester - VAL-EV-T2 280/3+1

1180144

<https://www.phoenixcontact.com/gb/products/1180144>

Feed-through terminal block

Feed-through terminal block - DK-BIC-35 - 2749880

<https://www.phoenixcontact.com/gb/products/2749880>



Feed-through terminal block for VAL and FLT applications

Wiring bridge

Wiring bridge - MPB 18/4- 8 - 2809283

<https://www.phoenixcontact.com/gb/products/2809283>



Wiring bridge for modules with connecting pitch 17.5 mm, 4-phase, 8-pos.

Type 2 surge arrester - VAL-EV-T2 280/3+1

1180144

<https://www.phoenixcontact.com/gb/products/1180144>

Type 2 surge protection plug

Type 2 surge protection plug - VAL-EV 280-P - 1180142

<https://www.phoenixcontact.com/gb/products/1180142>



CHARX protect: replacement plug for surge protective devices from the VALVETRAB EV-T2 product range for the L-N path.

Type 2 surge protection plug

Type 2 surge protection plug - F-EV 12-P - 1180140

<https://www.phoenixcontact.com/gb/products/1180140>



CHARX protect: replacement plug for surge protective devices from the VALVETRAB EV-T2 product range for the N-PE path.

Phoenix Contact 2022 © - all rights reserved
<https://www.phoenixcontact.com>

PHOENIX CONTACT Ltd
Halesfield 13, Telford
Shropshire, TF7 4PG
01952 681700
info@phoenixcontact.co.uk