



Raychem

TE Internal #: 096673-000

Heat Shrink Boots, 180 °, Size 202, Lipped, 4, 10, Adhesive Pre-Coat, -55 – 135 °C [-67 – 275 °F], Occasional Fluid Exposure, /86 Precoat

[View on TE.com >](#)

Wire Protection & Management > Heat Shrink Molded Shapes > Heat Shrink Boots > Low Profile Heat Shrink Boots: Poly Molded, Lipped, Straight

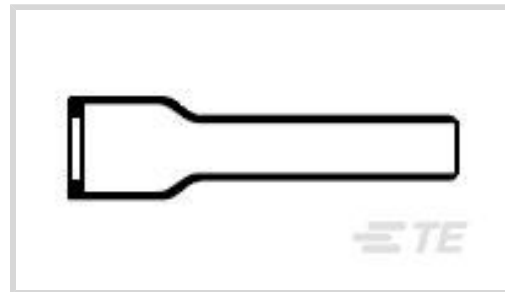

Molded Part Angle: 180 °

Molded Part Shape Code: 202

Lipped: Yes

Material Code: 4

Heat Shrink Boot Material Systems Code: 10

[All Low Profile Heat Shrink Boots: Poly Molded, Lipped, Straight \(223\)](#)

## Features

### Product Type Features

Molded Part Angle	180 °
-------------------	-------

### Configuration Features

Lipped	Yes
--------	-----

### Body Features

Material Code	4
Heat Shrink Boot Material Systems Code	10
Adhesive Pre-Coat	Yes
Material	Polyolefin Flexible Modified

### Dimensions

Wire/Cable Outside Diameter	.3 in, .31 in, .35 in, .39 in, .43 in, .433 in, .47 in, .55 in, 10 mm, 11 mm, 12 mm, 14 mm, 8 mm, 9 mm
Cable Diameter Range	7.4 – 16 mm[7.4 – 17 in]

### Usage Conditions

Operating Temperature Range	-55 – 135 °C[-67 – 275 °F]
-----------------------------	----------------------------

### Operation/Application

Power Cable Accessory	No
-----------------------	----



### Industry Standards

Approved Standards	SAE AS I 81765/1, Type II, UL 224, File E85381
Government Qualified	No

### Other

Molded Part Shape Code	202
Fluid & Chemical Resistance	Occasional Fluid Exposure
Adhesive Options	/86 Precoat
Adhesive Type	High Performance Pre-Coat Adhesive

### Product Compliance

[For compliance documentation, visit the product page on TE.com>](#)

EU RoHS Directive 2011/65/EU	Compliant
EU ELV Directive 2000/53/EC	Compliant
China RoHS 2 Directive MIIT Order No 32, 2016	No Restricted Materials Above Threshold
EU REACH Regulation (EC) No. 1907/2006	Current ECHA Candidate List: JAN 2022 (223) Candidate List Declared Against: JAN 2022 (223) Does not contain REACH SVHC
Halogen Content	Not Low Halogen - contains Br or Cl > 900 ppm.
Solder Process Capability	Not applicable for solder process capability

#### Product Compliance Disclaimer

This information is provided based on reasonable inquiry of our suppliers and represents our current actual knowledge based on the information they provided. This information is subject to change. The part numbers that TE has identified as EU RoHS compliant have a maximum concentration of 0.1% by weight in homogenous materials for lead, hexavalent chromium, mercury, PBB, PBDE, DBP, BBP, DEHP, DIBP, and 0.01% for cadmium, or qualify for an exemption to these limits as defined in the Annexes of Directive 2011/65/EU (RoHS2). Finished electrical and electronic equipment products will be CE marked as required by Directive 2011/65/EU. Components may not be CE marked. Additionally, the part numbers that TE has identified as EU ELV compliant have a maximum concentration of 0.1% by weight in homogenous materials for lead, hexavalent chromium, and mercury, and 0.01% for cadmium, or qualify for an exemption to these limits as defined in the Annexes of Directive 2000/53/EC (ELV). Regarding the REACH Regulation, the information TE provides on SVHC in articles for this part number is based on the latest European Chemicals Agency (ECHA) 'Guidance on requirements for substances in articles' posted at this URL: <https://echa.europa.eu/guidance-documents/guidance-on-reach>

### Compatible Parts



TE Part # CJ2087-000  
HL2010E-KIT-120V

### Customers Also Bought

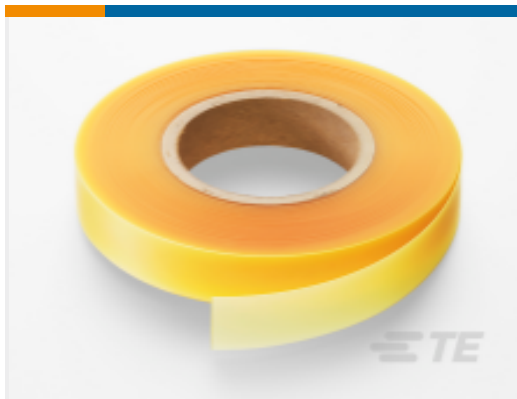

TE Part #890113-000  
S1048-TAPE-1X100-FT

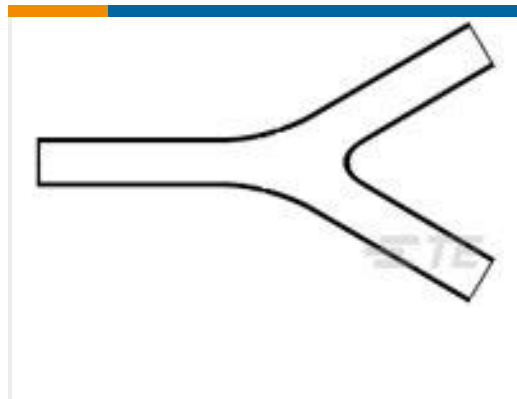

TE Part #462389-000  
381A302-51/164-0



TE Part #758621-000  
55A4121-22-9/96-9CS2275



TE Part #644807-000  
55A1121-22-9/96-9CS2275

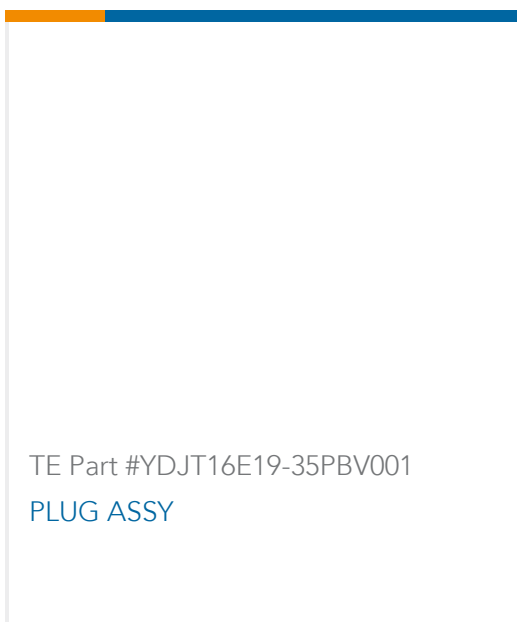

TE Part #YDJT16E19-35PBV001  
PLUG ASSY



TE Part #558823N001  
202D211-4/86-0-CS8240

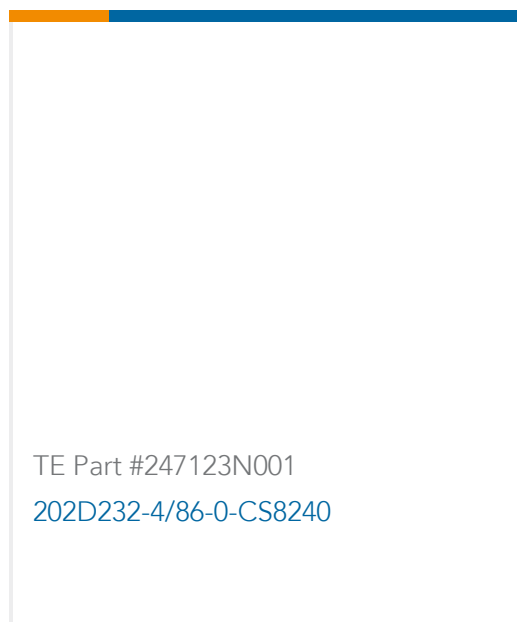

TE Part #247123N001  
202D232-4/86-0-CS8240

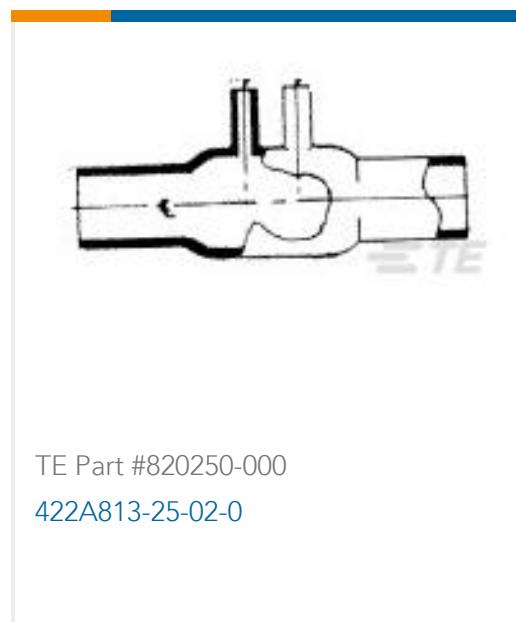

TE Part #820250-000  
422A813-25-02-0

### Documents

#### Product Drawings

[202D221-4/86-0](#)

English

#### Datasheets & Catalog Pages

[1654025\\_Sec4\\_-4](#)

English

#### Raychem Molded Parts Visual Guide

English

#### Product Specifications

[Product Specification](#)

English

#### Product Environmental Compliance

[Safety Datasheet](#)

[Safety Datasheet](#)

English



[Safety Datasheet](#)

French

[Safety Datasheet](#)

German

[Safety Datasheet](#)

[Safety Datasheet](#)

[Safety Datasheet](#)

[Safety Datasheet](#)

[Safety Datasheet](#)

[Safety Datasheet](#)

English

[Safety Datasheet](#)

French

[Safety Datasheet](#)

German

[Safety Datasheet](#)

[Safety Datasheet](#)

[Safety Datasheet](#)

[Safety Datasheet](#)

[Safety Datasheet](#)

English