

panel cutting

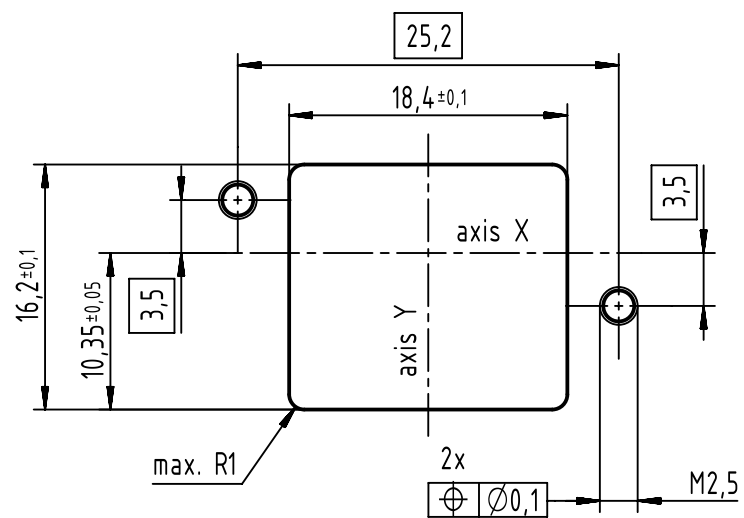

connector pitch on panel:  
axis X = 27mm and axis Y = 21mm 2

panel thickness = max. 5.5mm

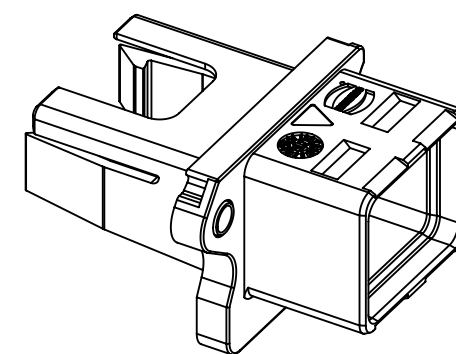
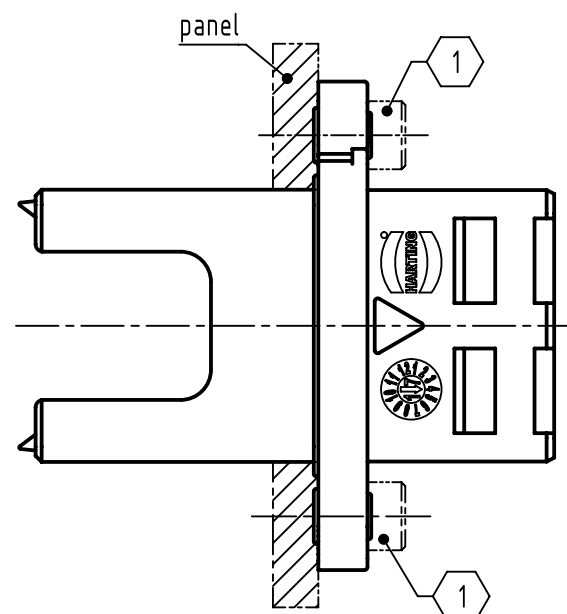

2 connector pitch with coding clip 0945840002X Y = 23mm

1 2x M2.5; screws acc. to ISO 4762;  
please order separately; bolting torque 0.3Nm - 0.5Nm

	All Dimensions in mm Original Size DIN A3		Scale 2:1	Free size tol.		Ref.	
	All rights reserved Department EC PD - DE		Created by ELLERMANN	Inspected by ZWAHR	Standardisation KOHLER	Date 2018-05-30	State Final Release
HARTING Electronics GmbH D-32339 Espelkamp		Title HARTING PushPull V4 Compact Housing Power				Doc-Key / ECM-Nr. 100626924/UGD/003/C 500000135700	
		Type TB	Number 09455450042			Rev. C	Page 1/1