

084 series

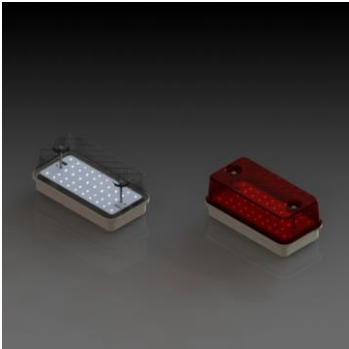

features



- LED Bulkhead Unit
- Available in a range of colours and voltages
- Featuring a metal base with polycarbonate lens
- Recommended for use as commercial and construction site security lighting, and retail indication lighting
- Rail approved version available
- Outstanding reliability and optical performance

Part Number	Colour	Voltage Vac/dc	Current DC (mA)	Luminous Intensity (mcd)	Wave Length (nm)	Operating Temp. (°C)	Storage Temp. (°C)	De-rating Graphs
084-501-22	Red	24	220	640	640	-40 - +100	-40 - +100	BB
084-521-22	Amber	24	220	690	600	-40 - +110	-40 - +110	AB
084-532-22	Green	24	220	870	520	-40 - +110	-40 - +110	AB
084-501-75	Red	110	40	640	640	-40 - +100	-40 - +100	BB
084-521-75	Amber	110	40	690	600	-40 - +110	-40 - +110	AB
084-532-75	Green	110	40	870	520	-40 - +110	-40 - +110	AB
084-997-75	White	110	40	1500	* See pg.2	-40 - +110	-40 - +110	AB
084-501-76	Red	230 Vac	20	640	640	-40 - +100	-40 - +100	BB
084-521-76	Amber	230 Vac	20	690	600	-40 - +110	-40 - +110	AB
084-532-76	Green	230 Vac	20	870	520	-40 - +110	-40 - +110	AB
084-930-76	Blue	230 Vac	20	310	460	-40 - +110	-40 - +110	AB
084-997-76	White	230 Vac	20	1500	* See pg.2	-40 - +110	-40 - +110	AB

specifications

Ordering information and typical characteristics (Ta = 25°C)

- ^ = Voltage for 20mA product is Vf at 20mA, not Vopr
- Products must be de-rated according to the de-rating information. Each de-graph refers to specific LEDs. Please refer to graphs on page 2.
 - Luminous intensity is measured at 20mA on a discrete LED unless otherwise stated.

© marl international limited technical documentation has been designed by marl international limited for the intention of providing information, which must not be copied or released to a third party without prior written consent from marl international limited. the information provided does not constitute part of any order or contract and should not be regarded as a representation relating to either products or service. no responsibility can be assumed for inaccuracies or printing errors. marl international limited reserve the right to alter without notice the specification or any conditions of supply for product or service.



rating

led bulkhead unit

084 series

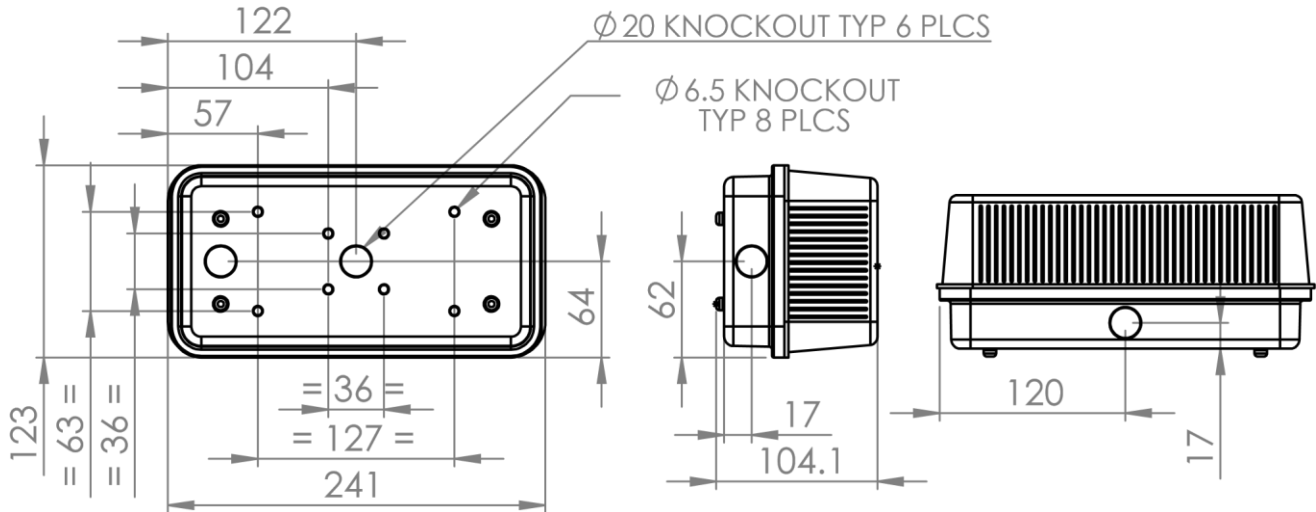

Dimensions in mm (typical)
Not to scale

Series	Max. Power Dissipation (mW)			
084	5000			
063	*Typical emission colour W ite			
x	0.280	0.264	0.283	0.296
y	0.248	0.267	0.305	0.276

Intensities (Iv) and colour shades of white (x,y co-ordinates) may vary between leds within a batch

de-rating information

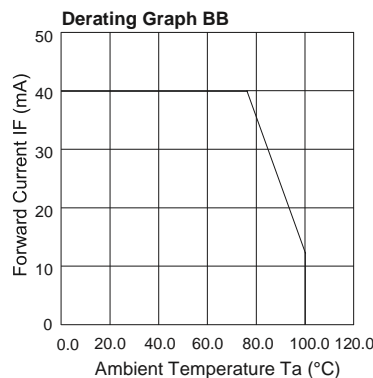
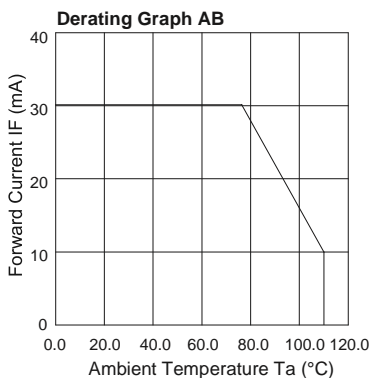

Part numbers also available in the 084 series:

© marl international limited technical documentation has been designed by marl international limited for the intention of providing information, which must not be copied or released to a third party without prior written consent from marl international limited. the information provided does not constitute part of any order or contract and should not be regarded as a representation relating to either products or service. no responsibility can be assumed for inaccuracies or printing errors. marl international limited reserve the right to alter without notice the specification or any conditions of supply for product or service.

084 series



Part Number	Colour	Voltage Vopr
	Red	230 Vac 50 Hz
	Green	230 Vac 50 Hz
	Red	24 Vdc
	Red	110 Vac 50 Hz
084-064-76-50	Red	110 Vac 50 Hz
084-065-76-50		
084-501-22-99		
084-501-75-50		
084-501-75-99		
084-501-76-65		
084-501-76-99		
084-501-99-64		
084-930-75		
	Red	230 Vac 50 Hz
	Red	230 Vac 50 Hz
	Red	110 Vac/dc
	Blue	110 Vac 50 Hz
084-997-22	White	24 Vdc
084-997-76-65	White	230 Vac 50 Hz
084-997-76-S	White	230 Vac 50 Hz
084-997-99-64	White	110 Vac/dc

The products listed above illustrate all of the options available to order. These products may have custom modifications that alter their operation beyond the generic information contained within this datasheet. Please contact sales for further information.

RP = Reverse Polarity

to order

Single-Chip LEDs

All devices feature water clear high intensity LEDs as standard.

Product Evaluation

Filament replacement LEDs have been specifically designed to meet the primary objective of providing improved reliability. Care should be taken to correctly simulate operating ambient light conditions to ensure that the correct device has been selected to maximise viewing characteristics such as viewing angle, colour compatibility and on/ off contrast ratio.

Electro-Static Discharge (ESD)

Build up of electro-static discharge occurs in many situations involving people moving and handling products. The range of possible situations is very diverse but voltage levels as high as several thousand volts can and do arise in many individual situations. When an operator charged up to these levels handles a static sensitive device, there is a very probable likelihood that the device will be irreversibly damaged. It is essential that precautions are taken at all stages during manufacture and assembly of these products. Although LEDs were never considered to be static sensitive devices, changes in manufacturing technology and materials used to produce higher intensity products over a large range of the wavelength spectrum have changed this. Marl has an approved system of ESD control from goods in, through production and into final packing and despatch. Marl recommend all users of LED based products follow the guidelines of BS 100015.

© marl international limited technical documentation has been designed by marl international limited for the intention of providing information, which must not be copied or released to a third party without prior written consent from marl international limited. the information provided does not constitute part of any order or contract and should not be regarded as a representation relating to either products or service. no responsibility can be assumed for inaccuracies or printing errors. marl international limited reserve the right to alter without notice the specification or any conditions of supply for product or service.

084 series



Power De-Rating

The forward voltage/ current value of an LED is dependant upon the ambient temperature of the environment in which it is operated. Therefore, care must be taken to operate the LED at the correct voltage/ current values, depending upon the ambient temperature. Consequently, a recommendation regarding operating voltages and currents is given in order to address these temperature effects. This recommendation is termed 'de-rating'. It is usual for forward voltages and currents to be specified for ambient temperature of 25°C. However, because the values of these qualities vary with temperature, marl should be contacted if the device is to be operated at a temperature significantly higher than 25°C. Marl accept no liability for any product that is operated higher than the stated voltage.

© marl international limited technical documentation has been designed by marl international limited for the intention of providing information, which must not be copied or released to a third party without prior written consent from marl international limited. the information provided does not constitute part of any order or contract and should not be regarded as a representation relating to either products or service. no responsibility can be assumed for inaccuracies or printing errors. marl international limited reserve the right to alter without notice the specification or any conditions of supply for product or service.