

Kühlschienen

Extruded profiles / Profiles extrudés de refroidissement

KS 108

Länge (mm): 50/75/100/150/1000
Gewicht (g/cm): 25,6

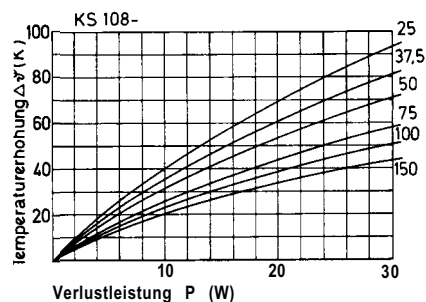
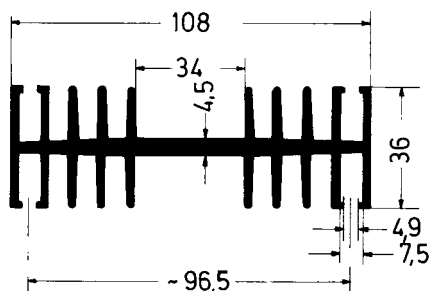

KS 111

Länge (mm): 50/75/100/150/1000
Gewicht (g/cm): 17,5

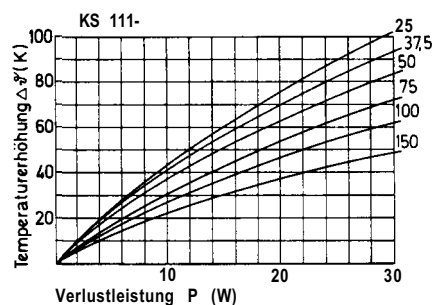
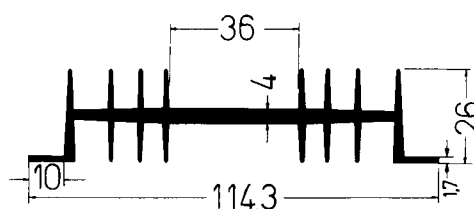

KS 112.1

Länge (mm): 50/75/100/150/1000
Gewicht (g/cm): 87

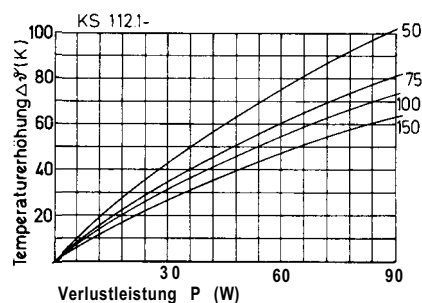
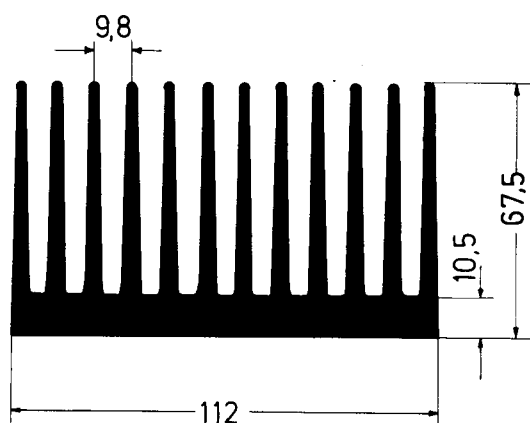

KS 120.9

Länge (mm): 37,5/50/75/100/150/1000
Gewicht (g/cm): 59,2

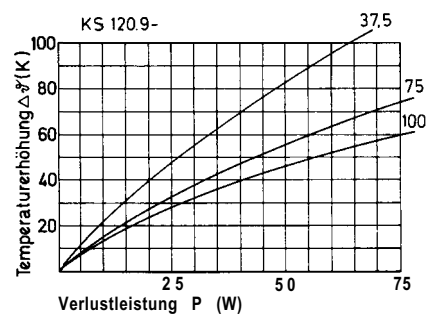
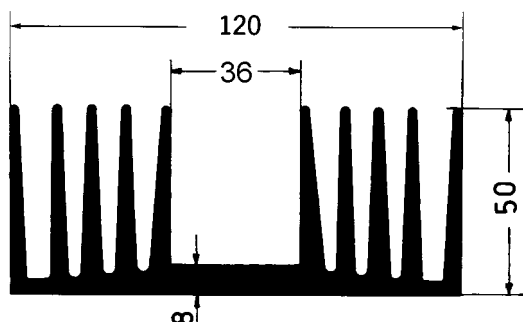

KS 127.2

Länge (mm): 100/150/200/1000
Gewicht (g/cm): 74

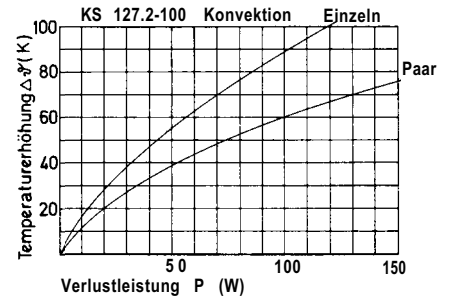
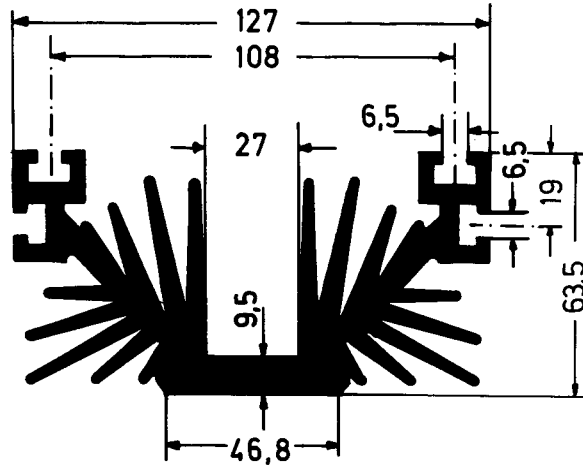

KS 143.1

Länge (mm): 37,5/50/75/100/150/1000
Gewicht (g/cm): 55

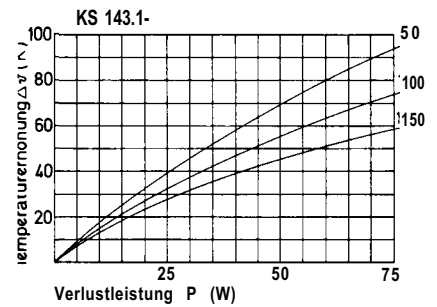
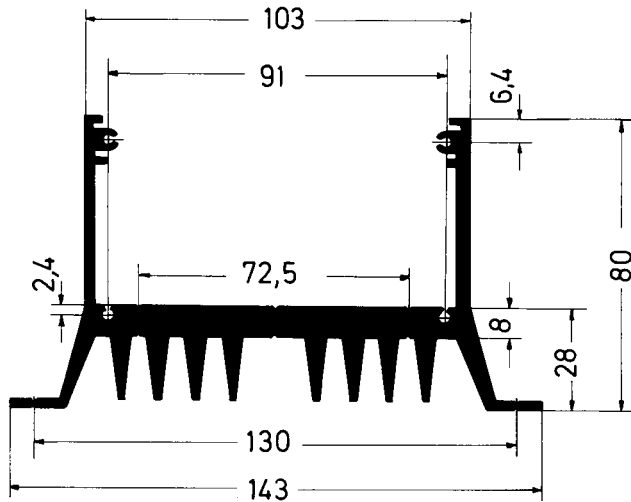

KS 150

Länge (mm): 37,5/50/75/100/150/1000
Gewicht (g/cm): 50

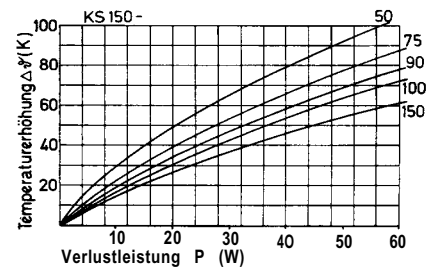
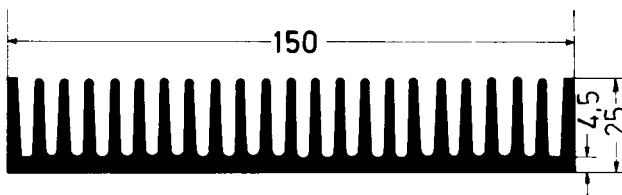

KS 160

Länge (mm): 75/100/150/1000
Gewicht (g/cm): 91

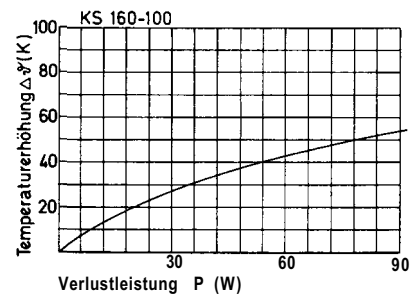
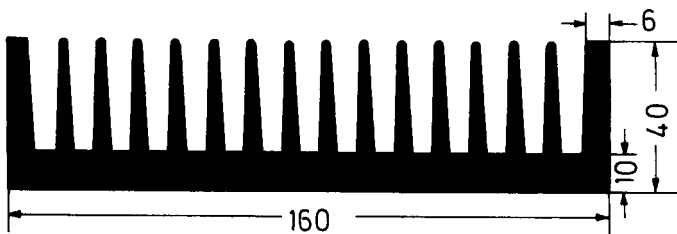

KS 200

Länge (mm): 37,5/50/75/100/150/1000
Gewicht (g/cm): 53,7

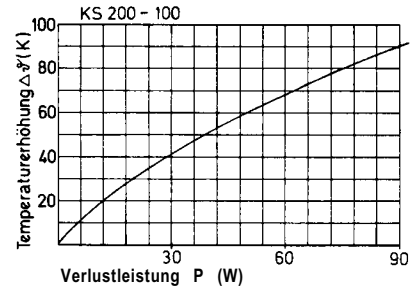
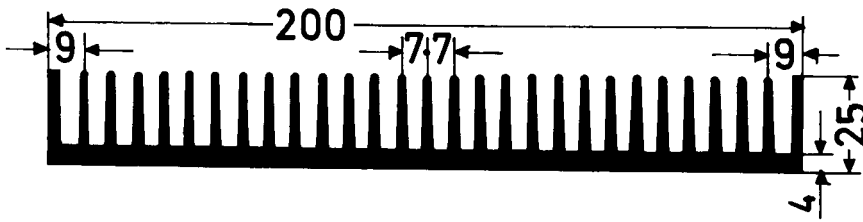

KS 216

Länge (mm): 37,5/50/75/100/150/1000
Gewicht (g/cm): 182

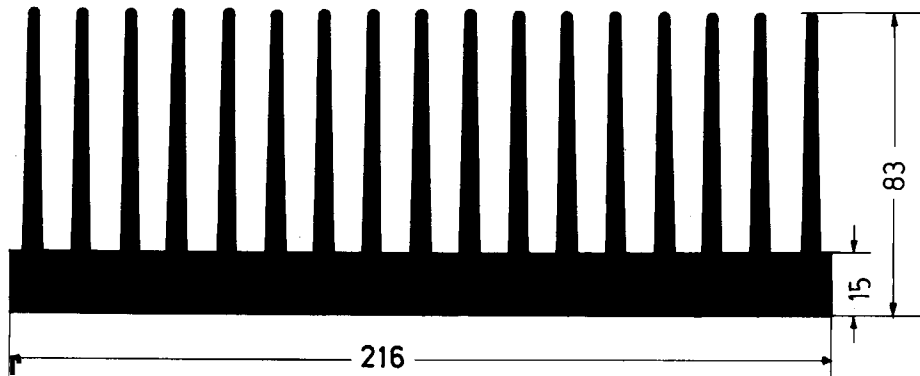
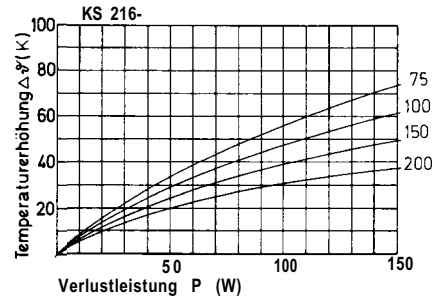
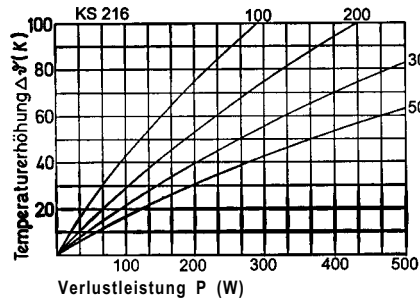

KS 300.6

Länge (mm): 100/150/200/250/300/
1000
Gewicht (g/cm): 255

