

Chip LED

15-21

Features:

- PACKAGE IN 8mm TAPE ON 177.8mm(7") DIAMETER REELS.
- COMPATIBLE WITH AUTOMATIC PLACEMENT EQUIPMENT.
- COMPATIBLE WITH INFRARED AND VAPOR PHASE REFLOW SOLDER PROCESS.
- EIA STD PACKAGE.
- I.C. COMPATIBLE.

Applications:

- Automotive:backlighting in dashboard and switch.
- Telecommunication:indicator and backlighting in telephone and fax.
- Indicator and backlight for audio and video equipment.
- Indicator and backlight for battery driven equipment.
- Small indicator for outdoor applications.
- Indicator and backlight in office equipment.
- Flat backlight for LCD, switch and symbol.
- General use.

Package Dimensions:

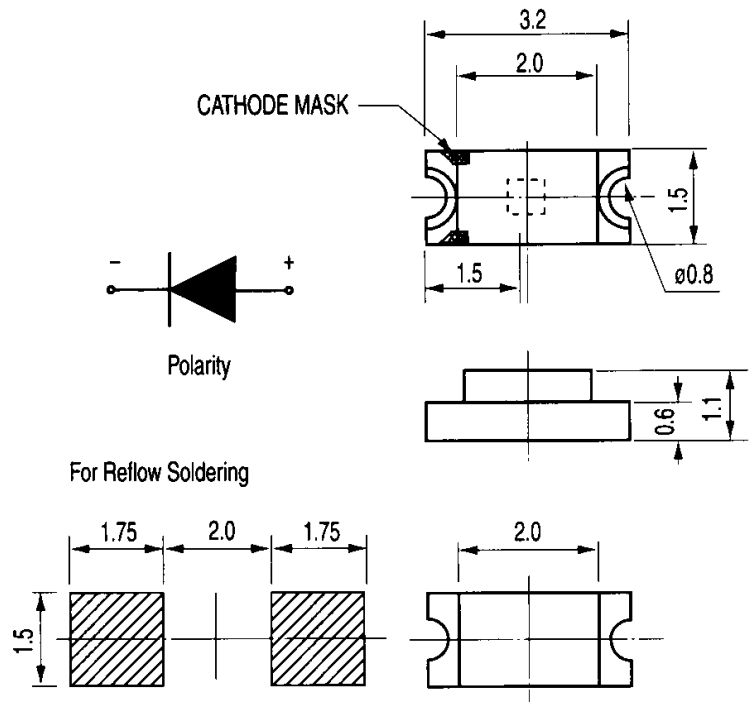

NOTES:

1. Tolerance Unless Dimension ± 0.1 mm Angle $\pm 0.5^\circ$.
2. Unit: mm

Model No:

MODEL	EMITTED COLOR	MATERIAL
EL-15-21VRC/TR8	RED	GaAsP/GaP
EL-15-21VGC/TR8	GREEN	GaP
EL-15-21VYC/TR8	YELLOW	GaAsP/GaP
EL-15-21SRC/TR8	SUPER RED	GaAlAs
EL-15-21UYC/S400/TR8	SUPER YELLOW	AlGaInP
EL-15-21USOC/S400/TR8	SUPER SUNSET ORANGE	AlGaInP

Absolute Maximum Ratings: (Ta=25°C)

Reverse Voltage	4 Volt
Reverse Current	100 μ A
Operating Temperature Range	-40°C to 85°C
Storage Temperature Range	-40°C to 90°C
Lead Soldering Temperature Range	260°C for 5 seconds

Part Selection and Application Information

MODEL	ABSOLUTE MAXIMUM RATING					ELECTRO-OPTICAL CHARACTERISTICS				Iv			VIEWING ANGLE 2 θ 1/2
	λ_p (nm)	$\Delta\lambda$ (nm)	Pd (mW)	If (mA)	If (peak) (mA)	Vf(V)			(Rec.) If (mA)	UNIT=mcd			
						Min.	Typ.	Max.		CONDITION=20mA			
	Min.	Typ.	Max.	Min.	Typ.				Max.	(deg)			
EL-15-21VRC/TR8	640	45	100	30	160	1.7	2.0	2.8	20	4.0	9.0	----	140
EL-15-21VGC/TR8	570	30	100	30	160	1.7	2.1	2.8	20	7.0	13.0	----	140
EL-15-21VYC/TR8	590	35	85	20	160	1.7	2.0	2.8	20	4.0	9.0	----	140
EL-15-21SRC/TR8	660	20	110	40	200	1.5	1.7	2.4	20	10.0	18.0	----	140
EL-15-21UYC/S400/TR8	590	15	100	50	160	1.7	2.0	2.8	20	27.0	47.0	----	140
EL-15-21USOC/S400/TR8	620	18	100	50	160	1.7	2.0	2.8	20	17.0	31.0	----	140

Viewing Angle:

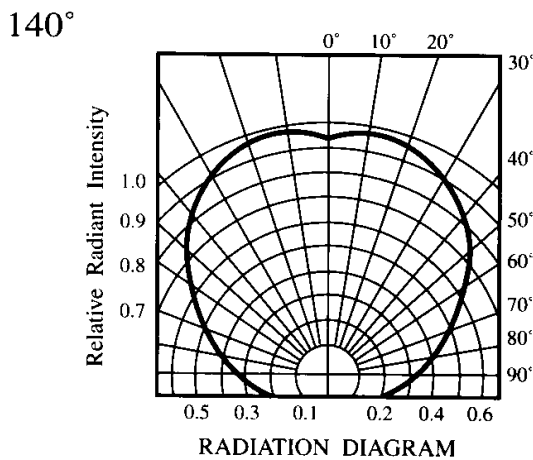

VR Series

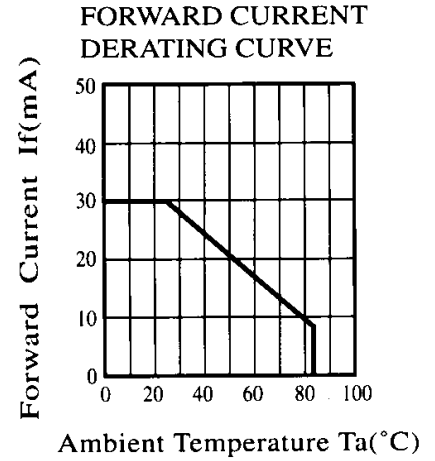
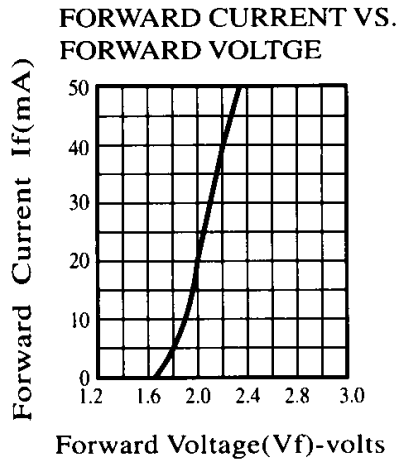
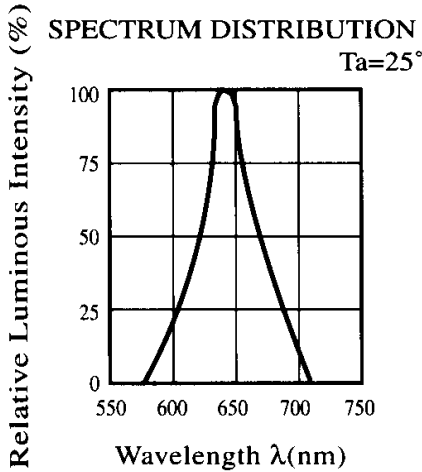

VG,UG Series

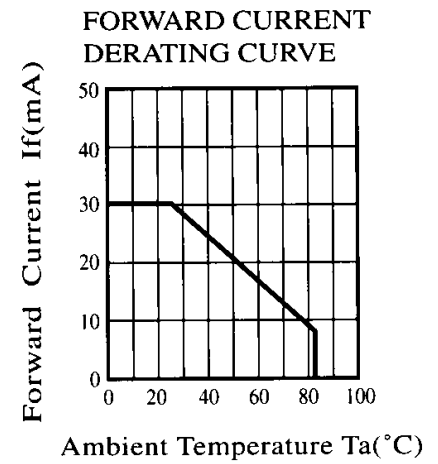
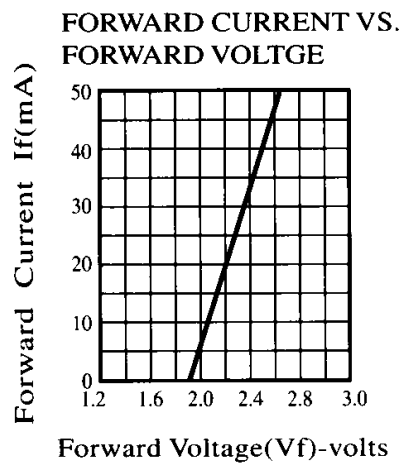
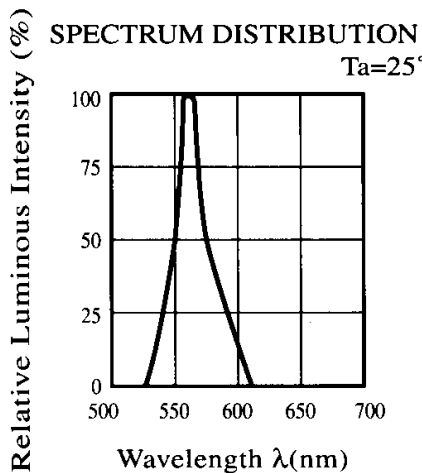

VY Series

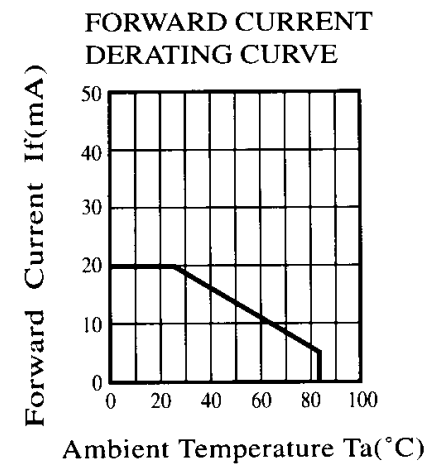
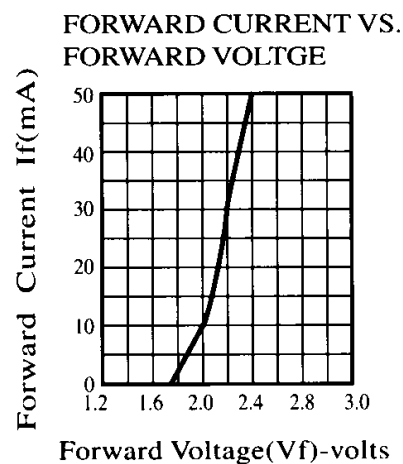
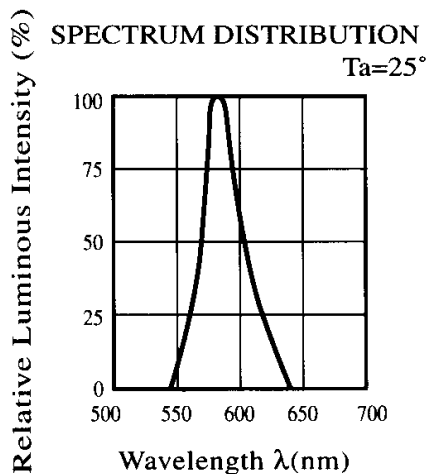

SR Series

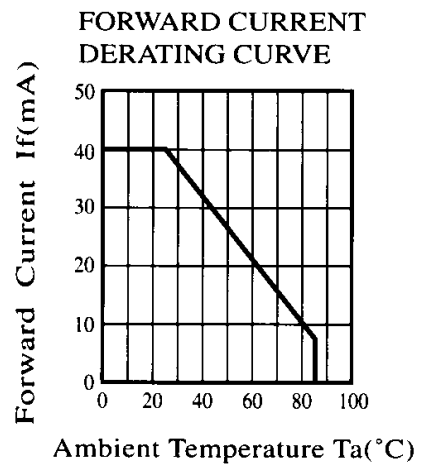
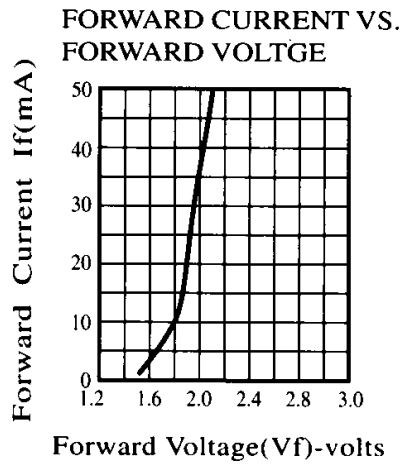
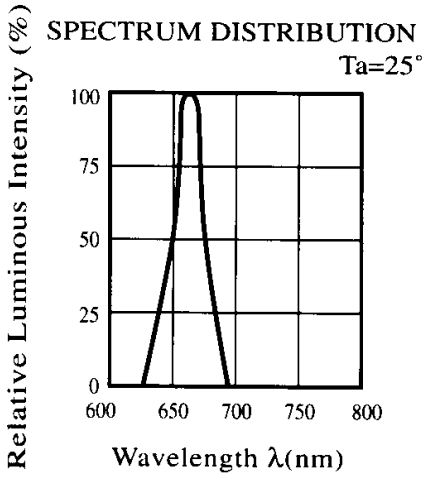

UY Series

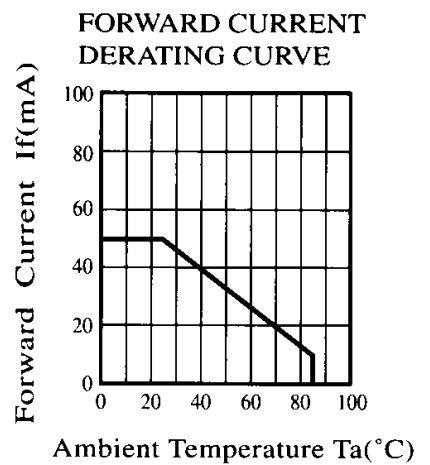
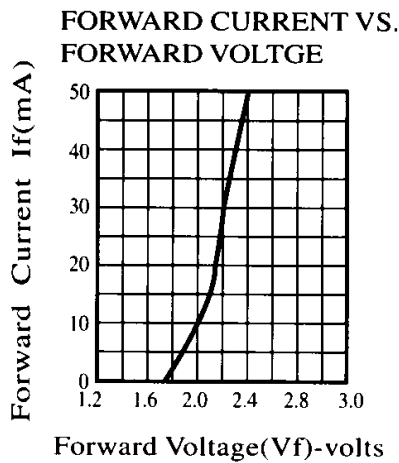
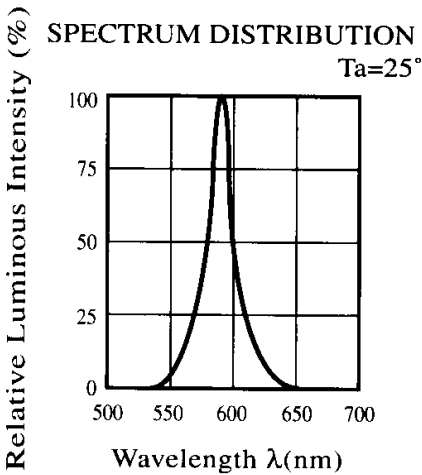

USO Series

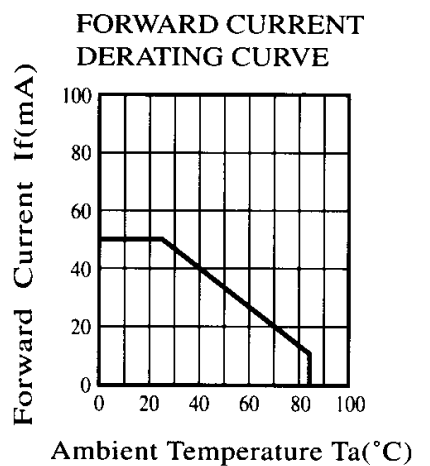
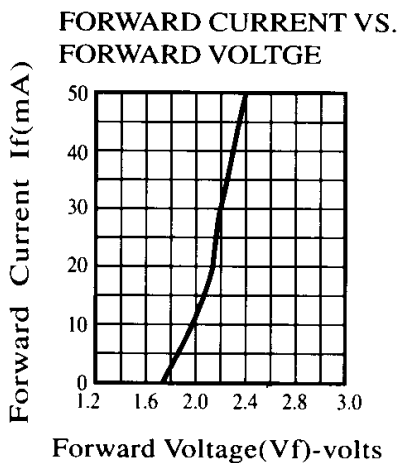
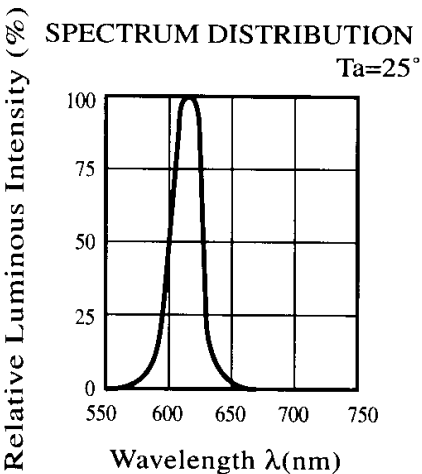

MODEL NO: 15-21 UGC/TR8

Device Number: DSE-151-028 REV. 1.2

page: ECN:

■ PART SELECTION AND APPLICATION INFORMATION

PARAMETER	SYMBOL	MIN.	TYP.	MAX.	UNIT	TEST CONDITION
Luminous Intensity	IV	7.0	12.0		mcd	If = 20 mA
Viewing Angle	2Θ1/2		140		deg	If = 20 mA
Peak Emission Wavelength	λP	-----	570	-----	nm	
Spectrum Radiation Bandwidth	Δλ	-----	30	-----	nm	
Forward Voltage	VF	1.7	2.1	2.8	V	If = 20 mA
Power Dissipation	Pd	-----	100	-----	mW	
Peak Forward Current (Duty 1/10 @ 1KHz)	If (Peak)	-----	-----	160	mA	
Recommended Operating Current	If (Rec)	-----	20	-----	mA	
Dc Forward Current	If	-----	-----	30	mA	

■ ABSOLUTE MAXIMUM RATINGS : (Ta = 25°C)

Reverse Voltage	: 4 Volt
Reverse Current	: 100 uA
Operating Temperature Range	: -30°C to 85°C
Storage Temperature Range	: -30°C to 90°C
Lead Soldering Temperature Range	: 260°C for 5 Seconds

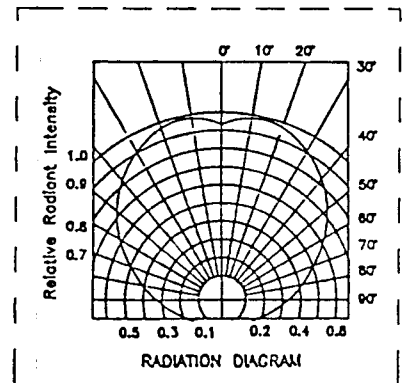

■ PART SELECTION AND APPLICATION INFORMATION

PARAMETER	SYMBOL	MIN.	TYP.	MAX.	UNIT	TEST CONDITION
Luminous Intensity	IV	21.5	35.5		mcd	If = 20 mA
Viewing Angle	2 θ 1/2		140		deg	If = 20 mA
Peak Emission Wavelength	λ P	-----	660	-----	nm	
Spectrum Radiation Bandwidth	$\Delta \lambda$	-----	20	-----	nm	
Forward Voltage	VF	1.5	1.7	2.4	V	If = 20 mA
Power Dissipation	Pd	-----	110	-----	mW	
Peak Forward Current (Duty 1/10 @ 1KHz)	If (Peak)	-----	-----	200	mA	
Recommended Operating Current	If (Rec)	-----	20	-----	mA	
Dc Forward Current	If.	-----	-----	40	mA	

■ ABSOLUTE MAXIMUM RATINGS : (Ta = 25°C)

Reverse Voltage	:	4 Volt
Reverse Current	:	100 uA
Operating Temperature Range	:	-30°C to 85°C
Storage Temperature Range	:	-30°C to 90°C
Lead Soldering Temperature Range	:	260°C for 5 Seconds

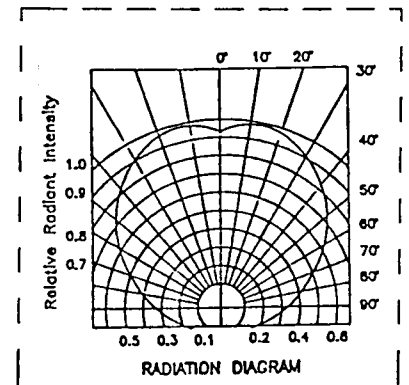

MODEL NO: 15-21 VGD/TR8

Device Number: DSE-151-026 REV. 1.3

page: _____ ECN: _____

■ PART SELECTION AND APPLICATION INFORMATION

PARAMETER	SYMBOL	MIN.	TYP.	MAX.	UNIT	TEST CONDITION
Luminous Intensity	IV	5.5	6.5		mcd	If = 20 mA
Viewing Angle	2 θ 1/2		140		deg	If = 20 mA
Peak Emission Wavelength	λ P	-----	570	-----	nm	
Spectrum Radiation Bandwidth	$\Delta \lambda$	-----	30	-----	nm	
Forward Voltage	VF	1.7	2.1	2.8	V	If = 20 mA
Power Dissipation	Pd	-----	100	-----	mW	
Peak Forward Current (Duty 1/10 @ 1KHz)	If (Peak)	-----	-----	160	mA	
Recommended Operating Current	If (Rec)	-----	20	-----	mA	
Dc Forward Current	If	-----	-----	30	mA	

■ ABSOLUTE MAXIMUM RATINGS: (Ta = 25°C)

Reverse Voltage	: 4 Volt
Reverse Current	: 100 μ A
Operating Temperature Range	: -30°C to 85°C
Storage Temperature Range	: -30°C to 90°C
Lead Soldering Temperature Range	: 260°C for 5 Seconds

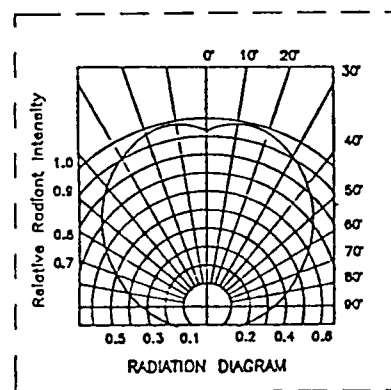

MODEL NO: 15-21 VRD/TR8

Device Number: DSE-151-025 REV. 1.2

page: _____ ECN: _____

■ PART SELECTION AND APPLICATION INFORMATION

PARAMETER	SYMBOL	MIN.	TYP.	MAX.	UNIT	TEST CONDITION
Luminous Intensity	IV	2.0	4.0		mcđ	If = 20 mA
Viewing Angle	2θ 1/2		140		deg	If = 20 mA
Peak Emission Wavelength	λ P	-----	640	-----	nm	
Spectrum Radiation Bandwidth	Δ λ	-----	45	-----	nm	
Forward Voltage	VF	1.7	2.0	2.8	V	If = 20 mA
Power Dissipation	Pd	-----	100	-----	mW	
Peak Forward Current (Duty 1/10 @ 1KHz)	If (Peak)	-----	-----	160	mA	
Recommended Operating Current	If (Rec)	-----	20	-----	mA	
Dc Forward Current	If	-----	-----	30	mA	

■ ABSOLUTE MAXIMUM RATINGS : (Ta = 25°C)

Reverse Voltage	:	4 Volt
Reverse Current	:	100 uA
Operating Temperature Range	:	-30°C to 85°C
Storage Temperature Range	:	-30°C to 90°C
Lead Soldering Temperature Range	:	260°C for 5 Seconds

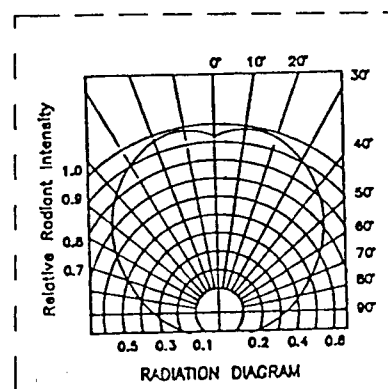

MODEL NO: 15-21 VYD/TR8

Device Number: DSE-151-027 REV. 1.3
 page: ECN:

■ PART SELECTION AND APPLICATION INFORMATION

PARAMETER	SYMBOL	MIN.	TYP.	MAX.	UNIT	TEST CONDITION
Luminous Intensity	IV	3.5	4.0		mcd	If = 20 mA
Viewing Angle	2 θ 1/2		140		deg	If = 20 mA
Peak Emission Wavelength	λP	-----	585	-----	nm	
Spectrum Radiation Bandwidth	$\Delta \lambda$	-----	35	-----	nm	
Forward Voltage	VF	1.7	2.0	2.8	V	If = 20 mA
Power Dissipation	Pd	-----	85	-----	mW	
Peak Forward Current (Duty 1/10 @ 1KHz)	If (Peak)	-----	-----	160	mA	
Recommened Operating Current	If (Rec)	-----	20	-----	mA	
Dc Forward Current	If	-----	-----	20	mA	

■ ABSOLUTE MAXIMUM RATINGS : (Ta=25°C)

Reverse Voltage	: 4 Volt
Reverse Current	: 100 uA
Operating Temperature Range	: -30°C to 85°C
Storage Temperature Range	: -30°C to 90°C
Lead Soldering Temperature Range	: 260°C for 5 Seconds

