

2000-10-26

# ELFA

## PRODUKTINFORMATION

Vi reserverar oss mot fel samt förbehåller oss rätten till ändringar utan föregående meddelande

ELFA artikelnr

75-060-17 A694B/2SYG 2LED+håll grön



# EVERLIGHT ELECTRONICS CO.,LTD.

Device Number : DAE-069-375 REV: 1.0

MODEL NO : A694B/2SYG/S530-E1 ECN : \_\_\_\_\_ Page: 1/5

## ■ Package Dimension:

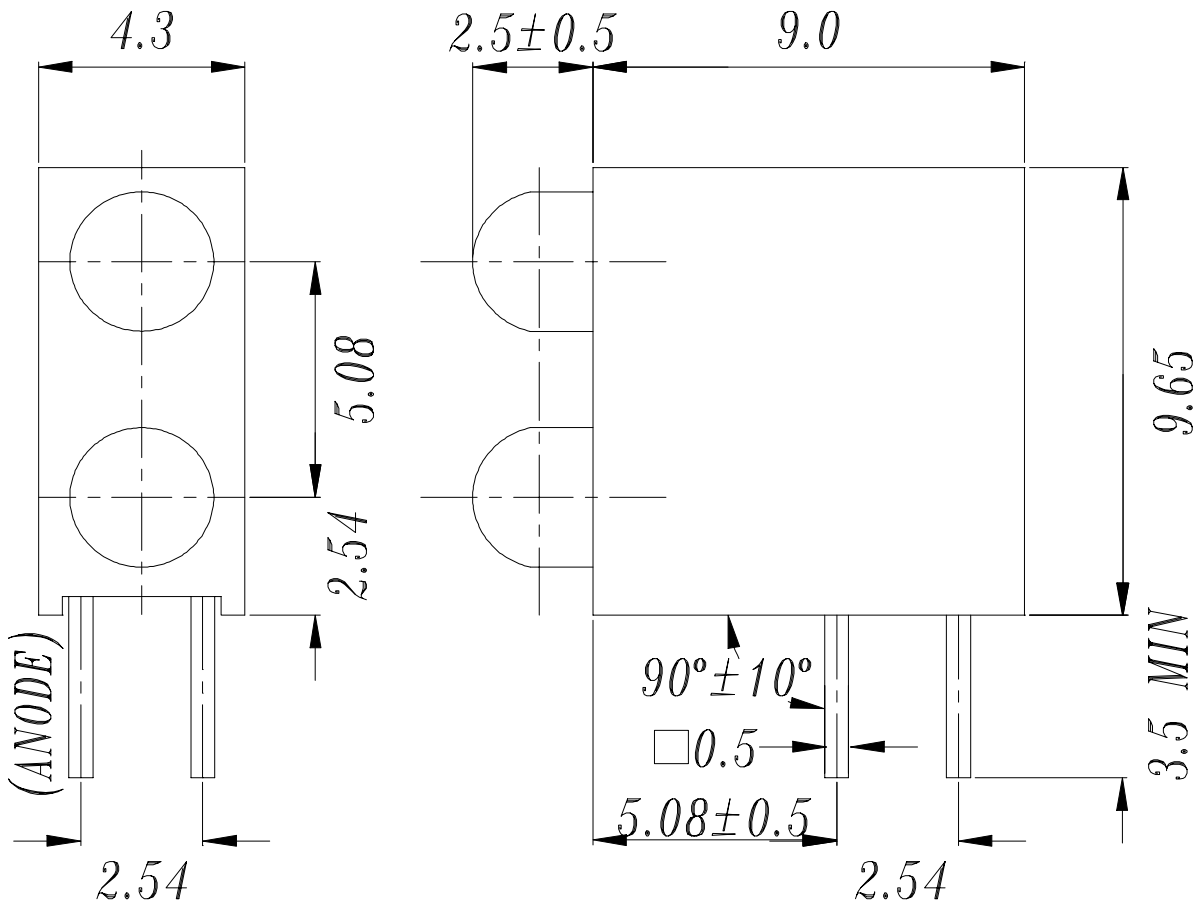

## ■ Notes:

- 1.All dimensions are in millimeters, tolerance is 0.25mm except be specified
- 2.Lead spacing is measured where the lead emerge from the package

LED PART NO	CHIP		Lens Color
	Material	Emitted Color	
234-10SYGD/S530-E1	AlGaInP	Super Yellow Green	Green Diffused

DESIGNER	CHECKER	APPROVER

Office : NO 25,Lane 76,Chung Yang Rd,Sec.3  
Tucheng,Taipei 236,Taiwan,R.O.C.

TEL : 886-2-2267-2000,2266-9936(22 Lines)



Device Number : DAE-069-374 REV: 1.0

MODEL NO : A694B/2SYG/S530-E1 ECN :          Page: 2/5

## ■ Description:

- 1.ARRAY=Plastic Holder+Combinations of Lamp
- 2.The array will easily mount the applicable lamps on any panel up to

## ■ Feature:

- 1.Low power consumption
- 2.High efficiency and low cost
- 3.Good control and free combinations on the colors of LED lamps
- 5.Good lock and easy to assembly
- 6.Stackable and easy to assembly
- 7.Stackable vertically and easy to assembly
- 8.Versatile mounting on P.C board or panel
- 9.Stackable horizontally and easy to assembly

## ■ Application:

- 1.Used as indicators of indicating the Degree, Functions, Positions etc, in electronic instruments.



■ LED LAMP ARRAYS SELECTION GUIDE:

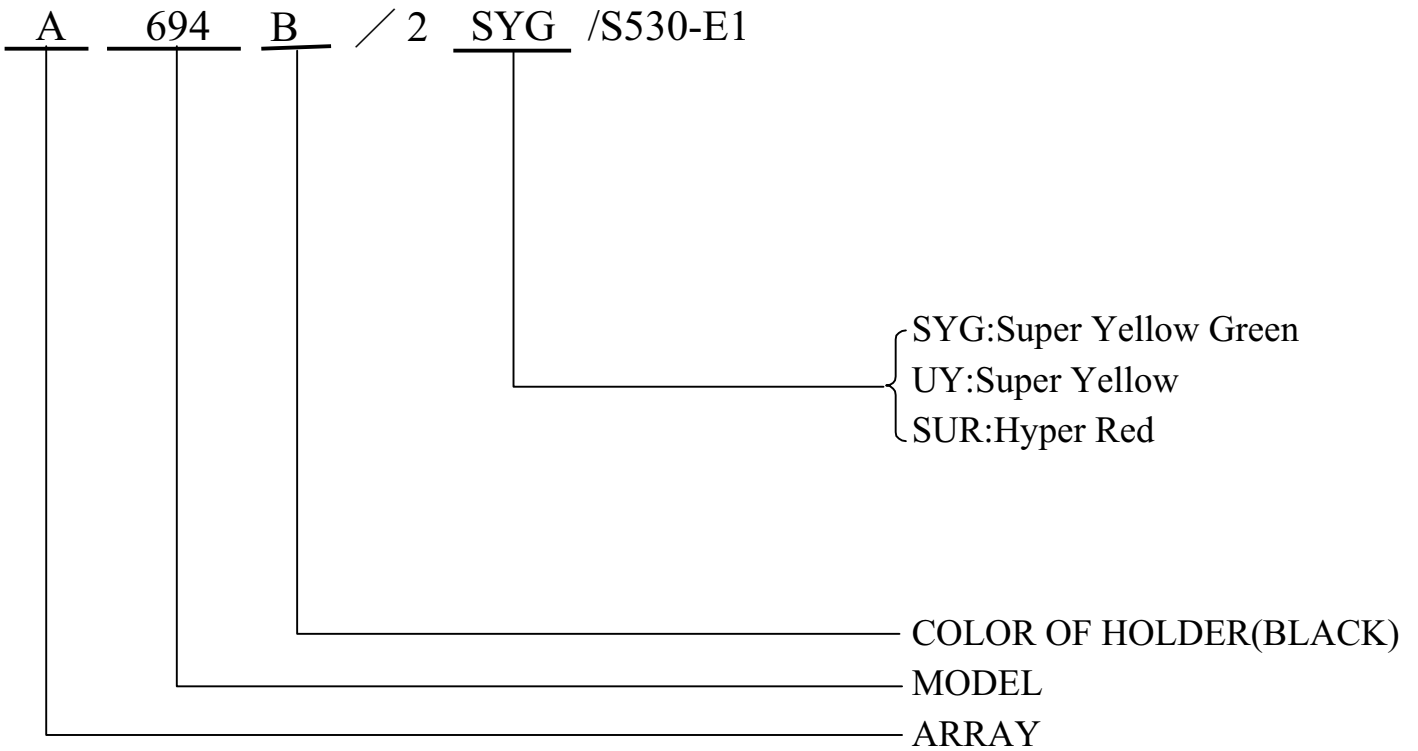



2.4\*5.0mm Rectangle Type LED Lamps

**Absolute Maximum Ratings at Ta = 25°C**

Parameter	Symbol	Rating	Unit
Forward Current	If	25	mA
Operating Temperature	Topr	-40 to +85	°C
Storage Temperature	Tstg	-40 to +100	°C
Soldering Temperature	Tsol	260 ± 5	°C
Electrostatic Discharge	ESD	2000	V
Power Dissipation	Pd	60	mW
Peak Forward Current(Duty 1/10 @ 1KHZ)	If(Peak)	160	mA
Reverse Voltage	Vr	5	V

**Electronic Optical Characteristics :**

Parameter	Symbol	MIN.	TYP.	MAX.	Unit	Condition
Luminous intensity	Iv	6	1.2 10	/	mcd	If= 2 mA If= 20 mA
Viewing Angle	2θ 1/2	/	60	/	deg	If= 20 mA
Peak Wavelength	λ p	/	575	/	nm	If= 20 mA
Dominant Wavelength	λ d	/	573	/	nm	If= 20 mA
Spectrum Radiation Bandwidth	Δ λ	/	20	/	nm	If= 20 mA
Forward Voltage	Vf	/	2.00	2.40	V	If= 20 mA
Reverse Current	Ir	/	/	10	μA	Vr= 5 V



■ Typical Electro-Optical Characteristic Curves

