

NYLON 6/6 UL 94 V-2 (RMS-01). COLOR: NATURAL. PART NO.	NYLON 6/6 UL 94 V-0 (RMS-19). COLOR: NATURAL. PART NO.	"A" REF	"B" REF	"C"	NOMINAL PANEL THICKNESS
MWSET1-1-01	MWSET1-1-19	4 [.16]	0.9 [.04]	3.3 [.13]	1.6 [.063]
MWSET1-1-1-01	MWSET1-1-1-19			4.1 [.16]	2.4 [.093]
MWSET1-2-01	MWSET1-2-19	6 [.24]	2.9 [.11]	3.3 [.13]	1.6 [.063]
MWSET1-2-1-01	MWSET1-2-1-19			4.1 [.16]	2.4 [.093]

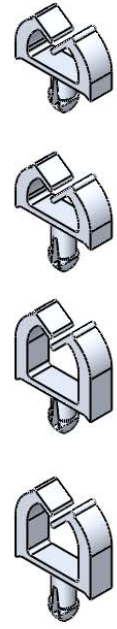
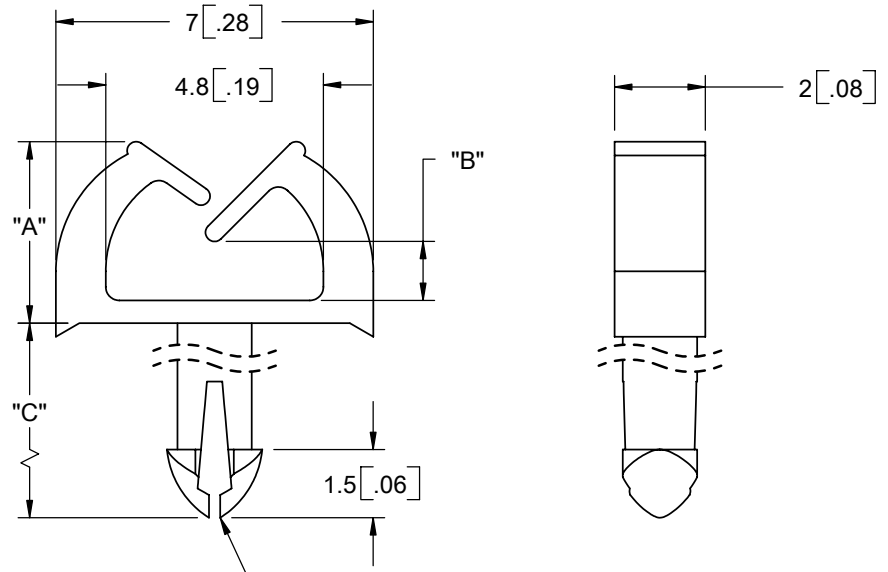

NOTES:  
1. ALTERNATE UNITS FOR REFETENCE ONLY

E			SEE ECN #1230 FOR CHANGES			SK	10/09/06	TITLE: MICRO WIRE SADDLE (TEARDROP)					DWG IN MM [IN]		
-			SEE ENGINEERING FOR REVISIONS A-D			-	----	CREATED USING SOLIDWORKS	FILE #: MWSET1	DWN: SK	APP: RT	FINAL			
REV.			DESCRIPTION			ENGR.	DATE	GENERAL TOLERANCE UNLESS OTHERWISE NOTED ±0.25 ANG.±1°	SHEET: 1 OF 1	SHEET SIZE: A	DT: 10/09/06	CHKD: SJ	PART #		PRINT TYPE
						RE: RICHCO, INC.			RICHCO, INC. ENG@RICHCO-INC.COM (773) 539-4060			SEE TABLE		CA	