



PRODUKTINFORMATION

Vi reserverar oss mot fel samt förbehåller oss rätten till ändringar utan föregående meddelande

ELFA artikelnr

50-024-98 Skärmbox 140x102x76 mm 461-0100

50-026-21 Skärmbox 140x102x76 mm 459-0100

Dimensions

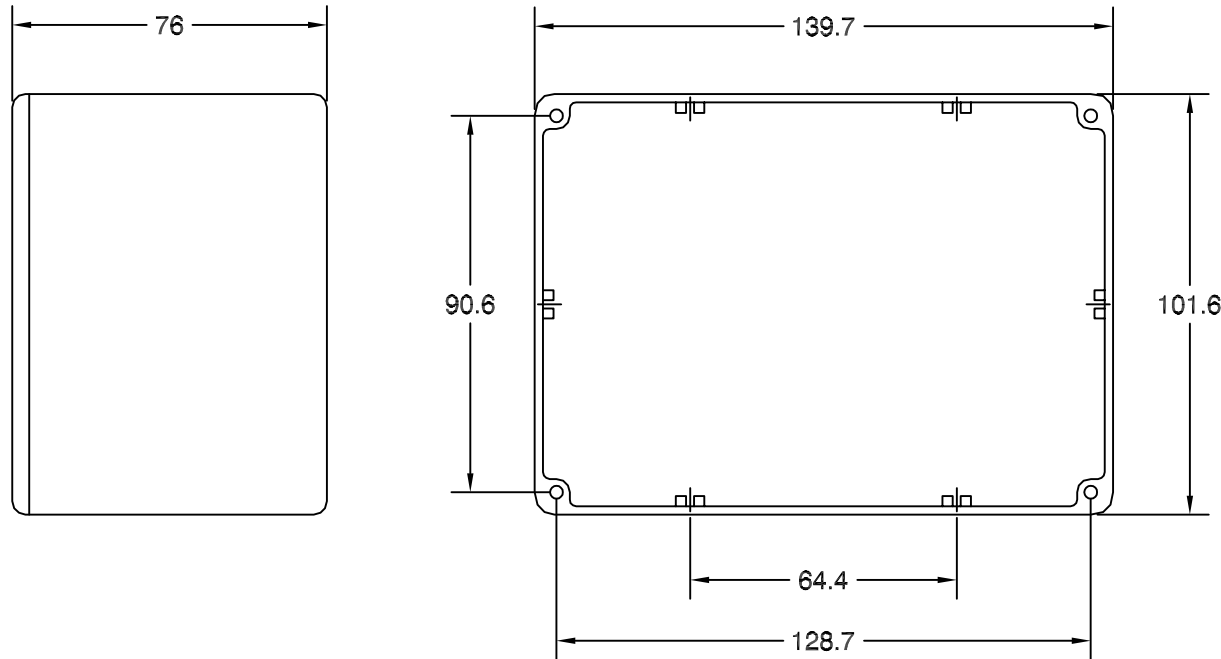

TAPER 1.5° PER SIDE
LID TO BASE

Description

A range of diecast boxes in various sizes, manufactured in a robust aluminium alloy. These lightweight enclosures provide excellent screening against EMI/RFI and are therefore ideal housing for electronic components and circuits.

The close fitting lid is secured using four countersunk screws. The box also incorporates integral PCB guides, and comes in a plain finish.

Features

MATERIAL BOX & LID	:Aluminium Alloy LM24
SCREWS	:Mild Steel M3.5x9
WALL THICKNESS	:2.0mm

CONVERTED FROM COREL. PS0263 ISS2

ALL DIMENSIONS IN MM / ANGLES IN DECIMAL DEGREES

DrgNo 459-0100-GS		TITLE DIECAST BOX - 'K' SIZE	
		ISSUE 3 GENERAL SPECIFICATION FOR 459-0100	CUSTOMER FILTER REF

Sheet 1 of 1 | Aprvd Date 15/04/02 | Aprvd By MC | Drwn by BS | SCALE NTS | CNN--- | Location N: \LONDON\GS\LGS00036

©DELTRON EMCON LTD, ROXBURGH HOUSE, FOXHILLS INDUSTRIAL PARK, SCUNTHORPE, NORTH LINCOLNSHIRE, DN15 8QJ TEL +44 1724 281770 F +44 1724 270230