



PRODUKTINFORMATION

Vi reserverar oss mot fel samt förbehåller oss rätten till ändringar utan föregående meddelande

ELFA artikelnr

50-024-72 Skärmbox 222x146x106 mm 461-0080

50-026-05 Skärmbox 222x146x106 mm 459-0080

50-029-77 Skärmbox 222x146x106 mm 462-0080

Dimensions

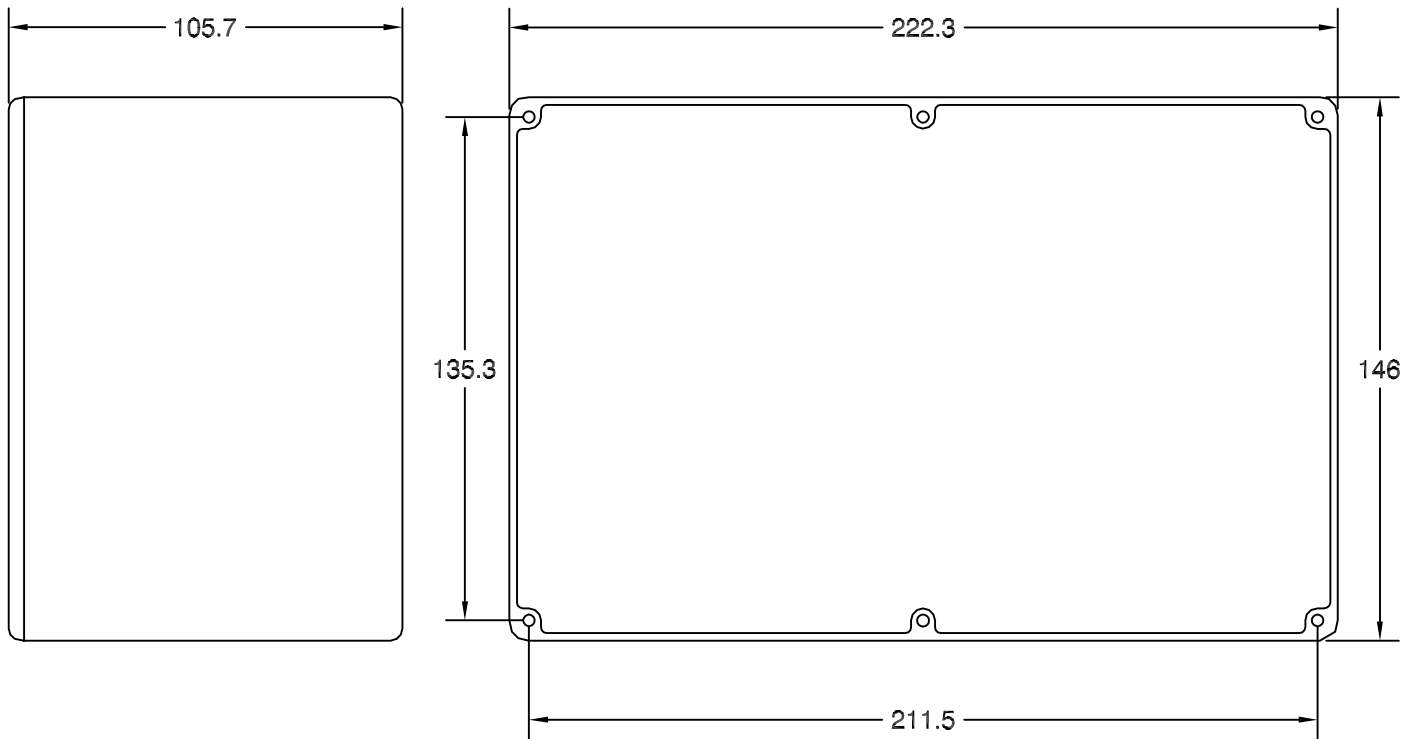

TAPER 1.5° PER SIDE
LID TO BASE

Description

A range of diecast boxes in various sizes, manufactured in a robust aluminium alloy. These lightweight enclosures provide excellent screening against EMI/RFI and are therefore ideal housing for electronic components and circuits.

The close fitting lid is secured using six countersunk screws. The box comes in a plain finish.

Features

MATERIAL BOX & LID	:Aluminium Alloy LM24
SCREWS	:Mild Steel M3.5x9
WALL THICKNESS	:2.0mm

CONVERTED FROM COREL. PS0261 ISS3

ALL DIMENSIONS IN MM / ANGLES IN DECIMAL DEGREES

DrgNo 459-0080-GS	TITLE DIECAST BOX - 'H' SIZE
-------------------	------------------------------

	ISSUE 4	GENERAL SPECIFICATION FOR 459-0080	CUSTOMER
			FILTER REF

Sheet 1 of 1	Aprvd Date 15/04/02	Aprvd By MC	Drwn by BS	SCALE NTS	CNN---	Location N: \LONDON\GS\LGS00034
--------------	---------------------	-------------	------------	-----------	--------	---------------------------------