

GMKDS 3/ 3-7,62

Order No.: 1731734

The illustration shows a 2-position version



<http://eshop.phoenixcontact.se/phoenix/treeViewClick.do?UID=1731734>

PC terminal block, Nominal current: 24 A, Nom. voltage: 500 V,
Pitch: 7.62 mm, Number of positions: 3, Type of connection: Screw
connection, Assembly: Soldering, Conductor/PCB connection
direction: 0 °, Color: green

Commercial data

EAN	4017918026417
Pack	50
Customs tariff	85369010
Catalog page information	Page 79 (CC-2007)

Product notes

WEEE/RoHS-compliant since:
2003-01-01



Please note that the data given here has been taken from the online catalog. For comprehensive information and data, please refer to the user documentation at <http://www.download.phoenixcontact.com>. The General Terms and Conditions of Use apply to Internet downloads.

Technical data

Dimensions / positions

Pitch	7.62 mm
Dimension a	15.24 mm
Number of positions	3
Pin dimensions	0,9 x 0,9 mm
Hole diameter	1.3 mm

Screw thread	M3
Tightening torque, min	0.5 Nm
Tightening torque max	0.6 Nm

Technical data

Insulating material group	I
Rated surge voltage (III/3)	6 kV
Rated surge voltage (III/2)	6 kV
Rated surge voltage (II/2)	6 kV
Rated voltage (III/2)	630 V
Rated voltage (II/2)	1000 V
Connection in acc. with standard	EN-VDE
Nominal current I_N	24 A
Nominal voltage U_N	500 V
Nominal cross section	2.5 mm ²
Maximum load current	30 A (with 4 mm ² conductor cross section)
Insulating material	PA
Inflammability class acc. to UL 94	V0
Internal cylindrical gage	A3
Stripping length	8 mm

Connection data

Conductor cross section solid min.	0.2 mm ²
Conductor cross section solid max.	4 mm ²
Conductor cross section stranded min.	0.2 mm ²
Conductor cross section stranded max.	2.5 mm ²
Conductor cross section stranded, with ferrule without plastic sleeve min.	0.25 mm ²
Conductor cross section stranded, with ferrule without plastic sleeve max.	2.5 mm ²
Conductor cross section stranded, with ferrule with plastic sleeve min.	0.25 mm ²
Conductor cross section stranded, with ferrule with plastic sleeve max.	2.5 mm ²
Conductor cross section AWG/kcmil min.	24
Conductor cross section AWG/kcmil max	12
2 conductors with same cross section, solid min.	0.2 mm ²
2 conductors with same cross section, solid max.	1.5 mm ²

2 conductors with same cross section, stranded min.	0.2 mm ²
2 conductors with same cross section, stranded max.	1.5 mm ²
2 conductors with same cross section, stranded, ferrules without plastic sleeve, min.	0.25 mm ²
2 conductors with same cross section, stranded, ferrules without plastic sleeve, max.	0.75 mm ²
2 conductors with same cross section, stranded, TWIN ferrules with plastic sleeve, min.	0.5 mm ²
2 conductors with same cross section, stranded, TWIN ferrules with plastic sleeve, max.	1.5 mm ²

Certificates



Certification

CCA, CSA, CUL, GL, GOST, SEV, UL

CSA

Nominal voltage U_N	300 V
Nominal current I_N	10 A
AWG/kcmil	28-12

CUL

Nominal voltage U_N	300 V
Nominal current I_N	10 A
AWG/kcmil	30-12

UL

Nominal voltage U_N	300 V
Nominal current I_N	10 A
AWG/kcmil	30-12

Drawings

Drilling diagram

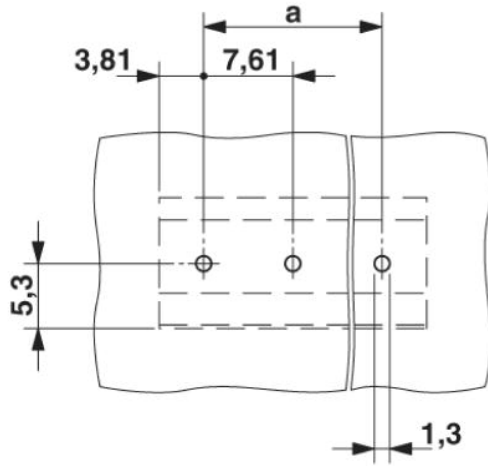

Dimensioned drawing

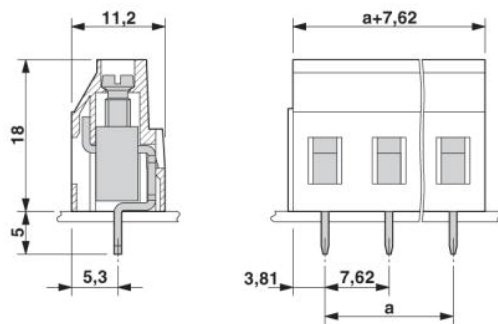

Address

Phoenix Contact AB
Linvägen 2
14144 Huddinge, Sweden
Phone +46 (0)8 - 608 64 00
Fax +46 (0)8 - 608 64 99
<http://www.phoenixcontact.se>

Phoenix Contact Oy
Technical modifications reserved;