

Customer Information Sheet

DRAWING No.: M80-842XXXX

SHEET 2 OF 2

IF IN DOUBT - ASK

(C)

NOT TO SCALE

THIRD ANGLE PROJECTION

ALL DIMENSIONS IN mm

ORDER CODE:

M80-842XXXX

TOTAL No. OF WAYS
02-07, 17, 22

FINISH

45 - GOLD
42 - SELECTIVE GOLD / 100% TIN

2.00 x No. OF WAYS + 4.00 MAX

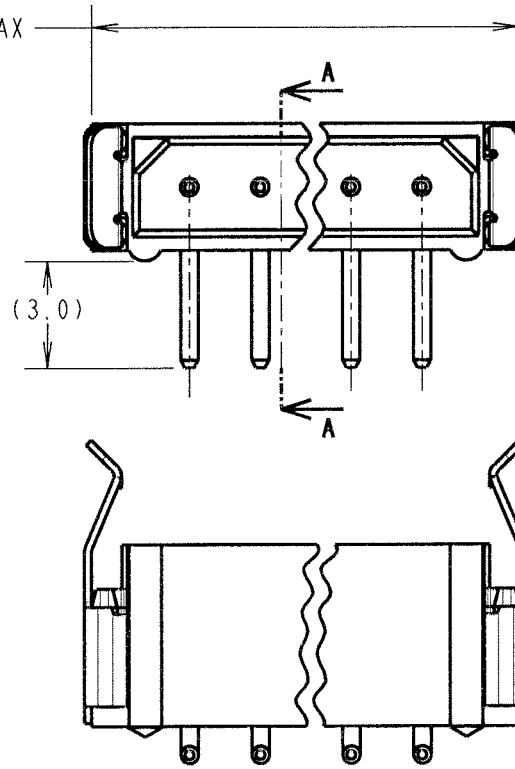

SECTION A-A

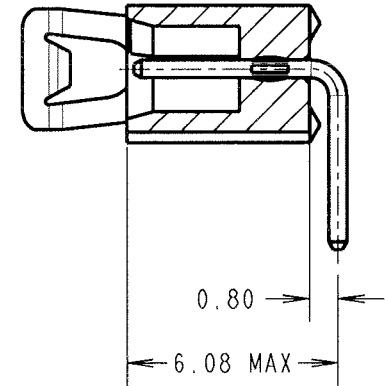

NOTES:

1. 2-OFF STRAIN RELIEF STRAP M80-0030006 ARE INCLUDED WITH EACH CONNECTOR.

SPECIFICATIONS:

MATERIAL:

MOULDING = GLASS-FILLED POLYAMIDE 46 UL94V-0, BLACK

CONTACTS = PHOSPHOR BRONZE

LATCHES = BERYLLIUM COPPER

FINISH:

CONTACTS:

45 = 0.75µ GOLD

42 = 0.75µ GOLD ON CONTACT AREA, 3.0µ 100% TIN ON TAILS

LATCHES = 1.25µ NICKEL

ELECTRICAL:

CURRENT RATING AT 25°C = 3.0A MAX

CURRENT RATING AT 85°C = 2.2A MAX

WORKING VOLTAGE = 120V AC/DC

VOLTAGE PROOF = 360V AC/DC

CONTACT RESISTANCE (INITIAL) = 20 mΩ MAX

CONTACT RESISTANCE (AFTER CONDITIONING) = 25 mΩ MAX

INSULATION RESISTANCE (INITIAL) = 1,000 MΩ MIN

INSULATION RESISTANCE (AFTER CONDITIONING) = 100 MΩ MIN

MECHANICAL:

DURABILITY = 500 OPERATIONS

ENVIRONMENTAL:

TEMPERATURE RANGE = -55°C TO +125°C

PACKING:

TUBE

FOR COMPLETE SPECIFICATION, SEE COMPONENT SPECIFICATION C005XX (LATEST ISSUE)

2.00 x No. OF PITCHES

2.25 TYP

RECOMMENDED PCB LAYOUT

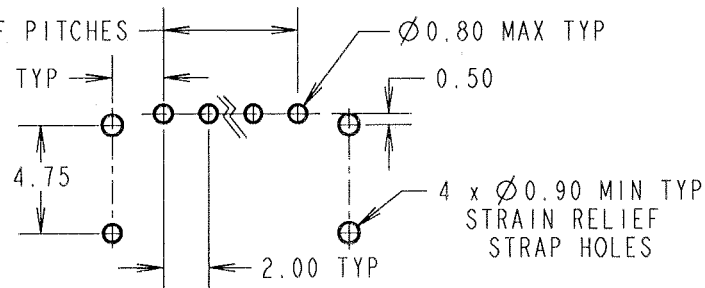

JMB	3	18.07.05	8633
NAME	ISS.	DATE	C/NOTE
APPROVED: <i>[Signature]</i>			
CHECKED: <i>[Signature]</i>			
DRAWN:		W J BOURNE	
CUSTOMER REF.:			
ASSEMBLY DRG:			

HARWIN

THIS DRAWING AND ANY INFORMATION OR DESCRIPTIVE MATTER SET OUT HEREON ARE CONFIDENTIAL AND COPYRIGHT PROPERTY OF THE HARWIN GROUP AND MUST NOT BE DISCLOSED, LOANED, COPIED OR USED FOR MANUFACTURING, TENDERING OR FOR ANY OTHER PURPOSE WITHOUT THEIR WRITTEN PERMISSION.

TOLERANCES

X. = ±1mm
X.X = ±0.25mm
X.XX = ±0.10mm
X.XXX = ±0.01mm
ANGLES = ±5°
UNLESS STATED

MATERIAL:

SEE ABOVE

FINISH:

S/AREA:

mm²

TITLE: DATAMATE 2mm PITCH HORIZONTAL PC TAIL SIL PLUG ASSEMBLY - LATCHED (R0HS)

DRAWING NUMBER:

M80-842XXXX

SHT
2
OF
2

HARWIN INC
U.S.A.

TEL: (812) 542 2540
FAX: (812) 542 2541

HARWIN PLC
U.K.

TEL: 023 9231 4545
FAX: 023 9231 4590

HARWIN PTE
SINGAPORE

TEL: 65 6779 4909
FAX: 65 6779 3868