

Toolless Enhanced Category 5 Jacks

1116604-X

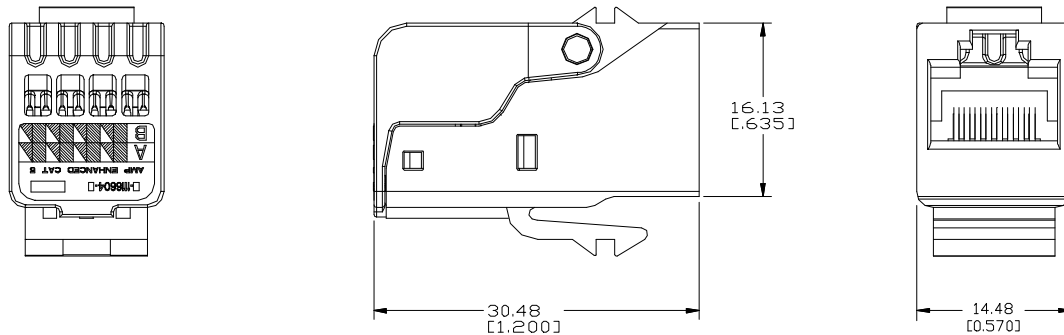

Description

AMP Enhanced Category 5 Toolless Modular Jacks exceed TIA requirements for Category 5e performance. They comply with all of the performance requirements for current and proposed applications such as 100BASE-Tx, 155 Mbps ATM and Gigabit Ethernet. Toolless Jacks can be terminated using common pliers and wire cutters. A hinged stuffer simplifies assembly. The universal wiring label permits field installation to either T568A or T568B wiring while simplifying ordering and inventory. The jacks fit AMP NETCONNECT SL Series and 110Connect faceplates.

Specification (Text in brackets [] requires a choice.)

Modular jacks shall be non-keyed, 4-pair and shall meet the performance requirements listed in the following table [\[include Performance Characteristics table from back page\]](#) in addition to all other standard Category 5 performance requirements. Modular jacks shall fit in a .790" X .582" opening. Modular jacks shall be terminated using an integral hinged stuffer cap, color-coded for both T568A and T568B wiring. Each jack shall be wired to [\[T568A or T568B\]](#). Modular jacks shall be UL Listed under file number E81956. Modular jacks shall be AMP part number [\[1116604-X \(X indicates color\)\]](#).

Part Number	Description
1116604-X	Category 5e Toolless modular jack, unshielded, unkeyed

X denotes color: -1 = Almond, -2 = Black, -3 = White, -4 = Gray, -5 = Orange, -6 = Blue, -7 = Red, -8 = Yellow, -9 = Green, 1- -0 = Violet, 1- -1 = Electrical Ivory

Toolless Enhanced Category 5 Jacks

1116604-X

Typical Worst-Case Performance Characteristics (exceed TIA/EIA-568-B.2 Category 5e)

Frequency, MHz	Attenuation, dB		NEXT, dB		PS NEXT, dB		FEXT, dB		Return Loss, dB	
	Spec	AMP	Spec	AMP	Spec	AMP	Spec	AMP	Spec	AMP
1	0.1	0.03	65.0	91.6	—	84.1	65.0	77.2	35.0	49.2
4	0.1	0.03	65.0	79.8	—	72.6	63.1	65.5	35.0	48.8
8	0.1	0.03	64.9	73.5	—	66.6	57.0	59.5	35.0	45.5
10	0.1	0.03	63.0	71.9	—	64.7	55.1	57.7	35.0	44.3
16	0.2	0.04	58.9	67.5	—	60.8	51.0	53.6	35.0	41.2
20	0.2	0.05	57.0	65.6	—	58.6	49.1	51.7	34.0	39.5
25	0.2	0.06	55.0	63.1	—	56.6	47.1	49.8	32.0	37.8
31.25	0.2	0.07	53.1	60.8	—	54.6	45.2	48.0	30.1	35.8
62.5	0.3	0.07	47.1	52.9	—	47.6	39.2	42.1	24.1	30.3
100	0.4	0.11	43.0	48.4	—	42.3	35.1	38.1	20.0	26.5

Wire range: 22-24 AWG, 1.14 [.045] maximum insulation diameter

Durability:

Modular jack - 750 mating cycles

Wire terminal - 25 termination cycles

Materials:

Housing - polyphethylene oxide, 94V-0 rated.

Stuffer cap - clear polycarbonate, 94V-0 rated.

Jack contacts - phosphorous bronze, plated with 1.27 μm [.000050] thick gold in localized area and 3.81 μm [.000150] minimum thick tin-lead in solder area over 1.27 μm [.000050] minimum thick nickel underplate.

Mounting panel thickness: 1.473 - 1.600 mm [.058 - .063"].

Packaging: 1 per bag/25 bags per carton, weight - 0.80 lb/carton

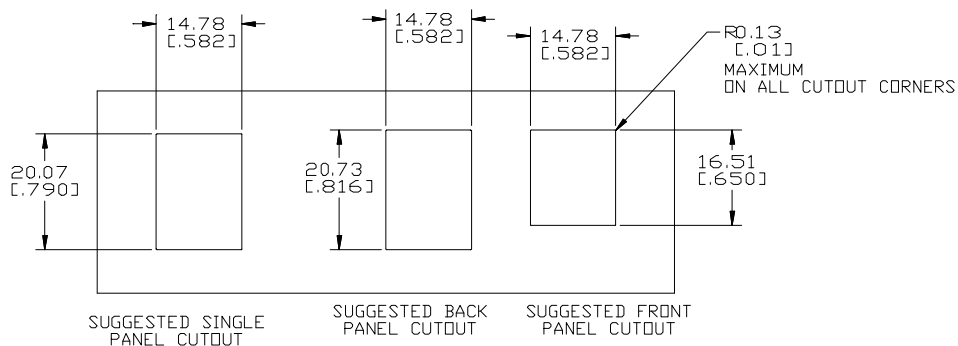

Specifications subject to change without notice.

Revised 8/00.

In the U.S. 1-800-553-0938

Canada 905-475-6222

Mexico 525-729-0400

South and Central Americas 54-11-4733-2200

www.amp.com/networking

e-mail: networking.help@tycoelectronics.com

tyco

Electronics

