

# Photoelectrics Retro-reflective Type PMR



- Range: 10 m
- Modulated, infrared light
- Make or break switching function (switch selectable)
- LED-indication for target detected
- Multi supply voltage:  
12 to 240 VDC and  
24 to 240 VAC, 50/60 Hz
- 25 x 65 x 81 mm reinforced PC housing, IP 67
- Timer options (adjustable)
- NO and NC output



## Product Description

Retro-reflective photoelectric switch. Range up to 10 m. Fixed sensitivity. Immune to ambient light. Output function switch selectable. Protection degree IP 67. Screw terminal connection. 25 x 65 x 81 mm

plastic housing. PG 13.5 or 1/2" NPT cable gland. Timer options: Delay on operate, delay on release, one shot (triggered on leading or trailing edge).

## Ordering Key **PMR10R G T**

Type \_\_\_\_\_  
 PG 13.5 cable gland \_\_\_\_\_  
 Option: Timer function \_\_\_\_\_

## Type Selection

Housing W x H x D	Range S <sub>n</sub>	Ordering no. without timer	Ordering no. with timer
25 x 65 x 81 PG 13.5 cable gland	10 m	PMR 10R G	PMR 10R GT
1/2" NPT cable gland	10 m	PMR 10R I	PMR 10R IT

## Specifications

<b>Rated operating dist. (S<sub>n</sub>)</b> (0 to 5,000 lux)	PMR10.. 10 m with reflector type ER 4, ref. target	<b>Operating frequency (f)</b>	20 Hz
<b>Rated operational volt. (U<sub>B</sub>)</b> (AC: 45 to 65 Hz)	10.8 to 264 VDC 21.6 to 264 VAC	<b>Response time</b> OFF-ON (t <sub>ON</sub> ) ON-OFF (t <sub>OFF</sub> )	≤ 20 ms ≤ 30 ms
<b>Rated operational power</b> (Relay ON)	≤ 1.5 W (2.0 VA)	<b>Power ON delay (t<sub>v</sub>)</b>	≤ 300 ms (typ. 100 ms)
<b>Output</b> Contact ratings (AgCdO) Resistive loads AC 1 DC 1 Small inductive loads AC 15 DC 13	μ (micro gap) 3 A/250 VAC 3 A/30 VDC 2 A/250 VAC 3 A/30 VDC	<b>Output function</b>	Switch selectable, make or break switching
Mechanical life Electrical life	≥ 40 x 10 <sup>6</sup> operations ≥ 5 x 10 <sup>5</sup> operations at 220 VAC - 3 A resistive load: 360 impulses/h	<b>Indication</b> Target detected	LED, yellow
<b>Dielectric voltage</b>	2000 VAC rms (cont./supply)	<b>Optional timer</b> Delay on operate Delay on release One shot	0.1 to 7 s ± 2 s 0.1 to 7 s ± 2 s 0.1 to 7 s ± 2 s
<b>Sensitivity</b>	Fixed	<b>Environment</b> Overvoltage category Pollution degree Degree of protection	III (IEC 664/664A; 947-1) 3 (IEC 664/664A; 947-1) IP 67 (IEC 529; 947-1)
<b>Light source</b> <b>Light type</b> <b>Optical angle</b> <b>Light spot size</b>	GaAlAs, LED, 880 nm infrared, modulated ±2° 280 mm at 4 m	<b>Temperature</b> Operating Storage	-25° to +55°C (-13° to +131°F) -30° to +80°C (-22° to +176°F)



## Specifications (cont.)

<b>Vibration</b>	10 to 150 Hz, 0.5 mm/7.5 g (IEC 68-2-6)
<b>Shock</b>	2 x 1 m & 100 x 0.5 m (IEC 68-2-32)
<b>Rated insulation voltage</b>	250 VAC (rms)
<b>Housing material</b>	
Body	PC, grey
Front	PC, black
Cover	PC, black
Cable gland	PA, black, reinforced
Mounting bracket	Steel, black
<b>Connection</b>	
Screw terminal	5 x 2 x 1 mm <sup>2</sup>
Cable gland	PG 13.5 or 1/2" NPT for cable 6 to 10 mm
<b>Weight</b>	110 g

## Connection Diagram

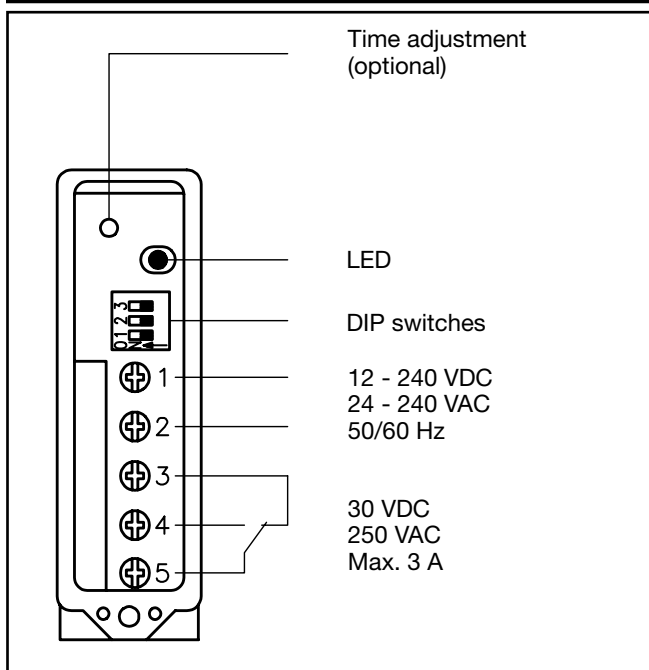

## Accessories

- Reflectors: ER series
- MB02 (longer mounting bracket)

For further information refer to "Accessories"

## Selection of Function

Switch  
1 2 3

PMR 10R .

PMR 10R .T

- 1 Break switching
- 2 Make switching
- 3 Delay on operate - Break switching
- 4 Delay on operate - Make switching
- 5 Delay on release - Break switching
- 6 Delay on release - Make switching
- 7 One shot, trailing edge - Break switching
- 8 One shot, trailing edge - Make switching
- 9 One shot, leading edge - Break switching
- 10 One shot, leading edge - Make switching

☒ Don't care

Upper position ON (Mode 1)  
Lower position OFF (Mode 0)

## Truth Table

	Make switching		Break switching	
	Yes	No	Yes	No
Object present	Yes	No	Yes	No
LED	OFF	ON	OFF	ON
Load	Non-active	Active	Active	Non-active

## Delivery Contents

- Photoelectric switch: PMR
- Cable gland
- Installation instruction
- Mounting bracket
- **Packaging:** Corrugated cardboard (environmentally friendly recycling material)

## Operation Diagram

t = Time delay  
tv = Power ON delay

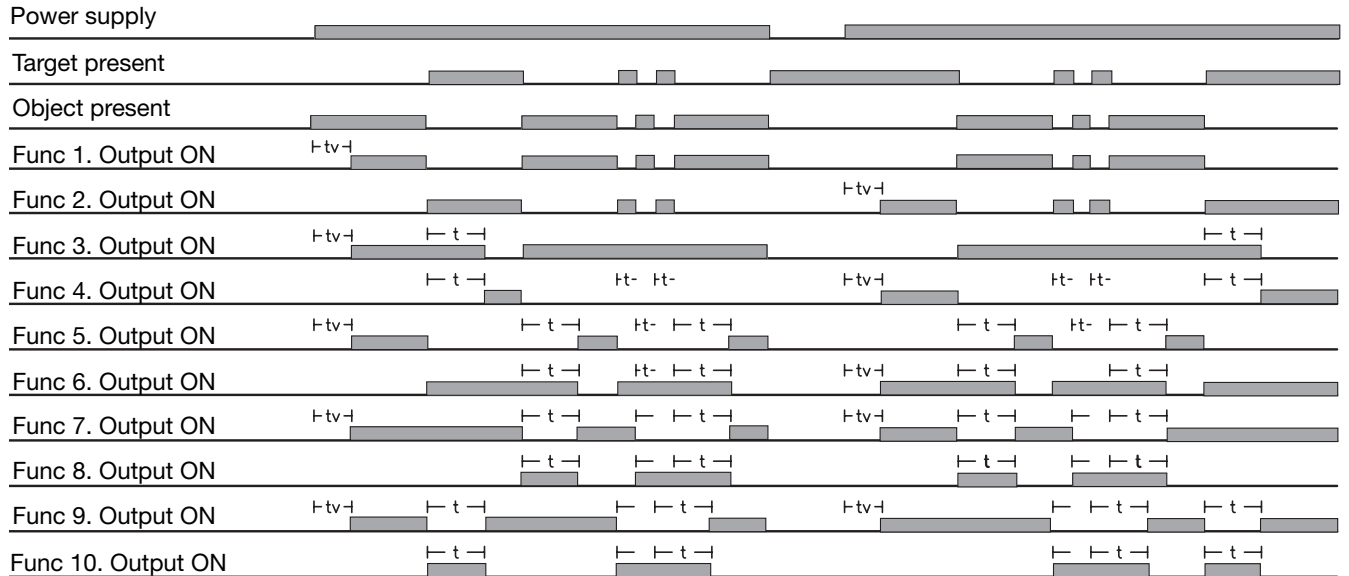

## Dimensions

