

**Panasonic**  
ideas for life

UNIQUELY DESIGNED RELAY

**K-RELAYS**

**FEATURES**

- 100 times more reliable than similar designs
- Extra long life — Mechanical: more than 10<sup>8</sup> operations  
Electrical (1 A 30 V): more than 10<sup>6</sup> operations
- Versatile range for all applications

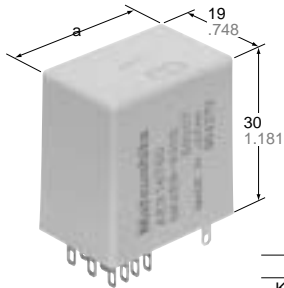

mm inch

	a	
K2EB	23.6	0.929
K4EB	29.4	1.157
K6EB	34.8	1.370

**Sealed construction**

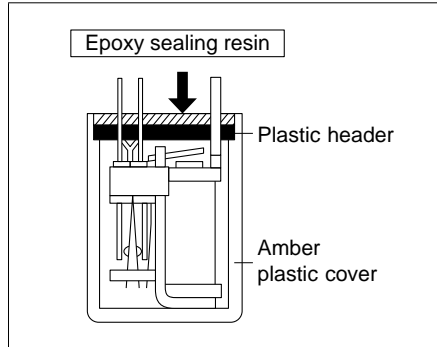

**Gold-clad bifurcated contacts**  
**Low and stable contact resistance**  
**Low level current switching possible**

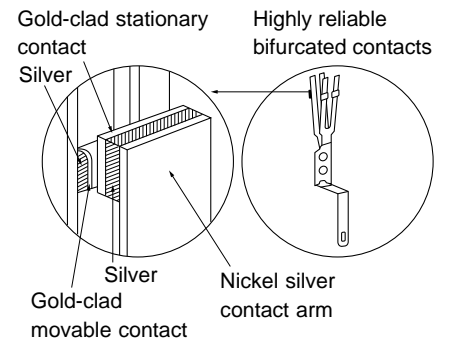

**SPECIFICATIONS**

**Contacts**

Arrangement		2, 4, 6 Form C
Rating (resistive load)	Max. switching power	50 W, 100 VA
	Max. switching voltage	220 V AC DC
	Max. switching current	2A
Expected life (min. operations)	Mechanical	10 <sup>8</sup>
	Electrical (1 A 100 V AC)	10 <sup>6</sup>
Contact material (Bifurcated contacts)	Movable contact	Gold-clad silver
	Stationary contact	Gold-clad silver
Initial contact resistance, max. (By voltage drop 6 V DC 1 A)		50 mΩ
Capacitance	Contact/Contact	3 pF
	Contact/Ground	5 pF

**Characteristics (at 20°C 68°F, 50% R.H.)**

Max. operating speed		50 cps.
Initial insulation resistance		Min. 1,000 MΩ at 500 V DC
Initial break-down voltage	Between open contacts, contact sets	750 Vrms
	Between live parts and ground	750 Vrms
	Between contacts and coil	750 Vrms
Operate time*1 (at nominal voltage)		Approx. 15 ms
Release time*1 (at nominal voltage)		Approx. 5 ms
Vibration resistance		98 m/s <sup>2</sup> {10 G}, 10 to 55 Hz at double amplitude of 1.6 mm
Shock resistance		98 m/s <sup>2</sup> {10 G}
Conditions for operation, transport and storage (Not freezing and condensing at low temperature)	Ambient temperature*2	2C, 4C: -40°C to +60°C -40°F to +140°F 6C: -40°C to +40°C -40°F to +104°F
	Humidity	5 to 85% R.H.
Ambient pressure		101, 325 Pa ±20% {1,013 mb ±20%}
Unit weight (approx.)		K2EB: 23 g .81 oz, K4EB: 27 g .95 oz, K6EB: 30 g 1.06 oz

\*1 Excluding contact bounce time

\*2 Total temperature (temperature rise in coil plus ambient temperature) should be kept less than max. 115°C 221°F

**ORDERING INFORMATION**

Ex. K 2 EB 24V 1

Contact arrangement	Type classification	Terminal	Coil (DC)	Sensitivity
2: 2 Form C 4: 4 Form C 6: 6 Form C	EB: Amber sealed type	Nil: Plug-in, solder terminal	3 to 110 V	Nil: High sensitivity relays 1: Ordinary sensitive relays

(Notes) 1. Other coil and contact specifications are available on request for orders of more than 1,000 pcs.  
Please state: Required coil resistance Gold clad/Gold clad contacts  
2. For UL/CSA or VDE recognized types, and suffix UL/CSA or VDE.  
3. Standard packing Carton: 20 pcs. Case: 200 pcs.

**TYPICAL APPLICATIONS**

**Typical applications include:**

Systems and equipment requiring higher reliability, Severe environmental uses, Alarm devices, Office machines, Telecommunication equipment, Pollution control equipment

**TYPES AND COIL DATA**

Part No.	Coil voltage (V)					Coil resistance* (? at 20°C)	Nominal coil power (mW)	Inductance (H)	
	Plug-in and Solder	Nominal (DC)	Pick-up (max. at 20°C)	Drop-out (min. at 20°C)	Max. allowable voltage, (at 40°C)			Armature	
								Closed	Open
2 Form C	K2EB-3V-1	3	1.8	0.27	6.7	28	320	0.52	0.26
	K2EB-6V-1	6	3.9	0.58	12.0	110	330	2.1	1.1
	K2EB-12V-1	12	8.0	1.2	30.0	530	270	11	5.6
	K2EB-24V-1	24	16.5	2.5	47.0	1,700	340	35	18
	K2EB-42V-1	42	30.0	4.5	72.0	5,300	333	95	48
	K2EB-48V-1	48	39.0	5.9	100.0	7,600	300	120	62
4 Form C	K4EB-110V-1	110	60.0	9.0	180.0	16,000	760	270	138
	K4EB-3V-1	3	2.3	0.35	5.0	18	500	0.36	0.18
	K4EB-6V-1	6	4.2	0.63	9.0	58	620	1.0	0.5
	K4EB-12V-1	12	8.7	1.3	18.5	250	580	5.2	2.6
	K4EB-24V-1	24	18.0	2.7	35.0	890	650	15	7.5
	K4EB-28V-1	28	19.0	2.85	33.0	1,100	713	20	11
6 Form C	K4EB-48V-1	48	36.0	5.4	64.0	3,200	720	54	28
	K4EB-110V-1	110	85.0	12.8	160.0	16,000	760	270	138
	K6EB-6V	6	4.2	0.63	6.6	28	1,286	0.52	0.26
	K6EB-12V	12	8.4	1.26	13.2	110	1,309	2.1	1.1
	K6EB-24V	24	16.8	2.52	26.4	440	1,309	8.3	4.2
	K6EB-48V	48	33.6	5.04	52.8	1,700	1,355	35	18
6 Form C	K6EB-60V	60	42.0	6.3	66.0	2,800	1,286	44	23
	K6EB-110V	110	77.0	11.55	121.0	10,000	1,210	164	84

\* Less than 1,000 W: ±10% More than 1,000 W: ±15%

**REFERENCE DATA**

1. Life curve

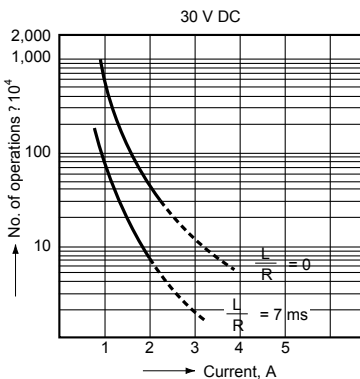

2. Coil temperature rise (resistance method)

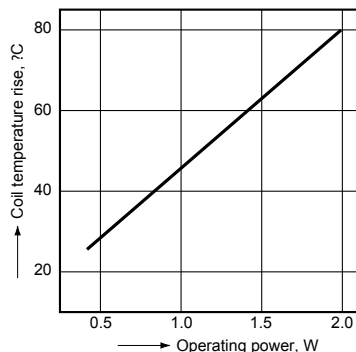

3. H<sub>2</sub>S gas test (1,000 ppm)

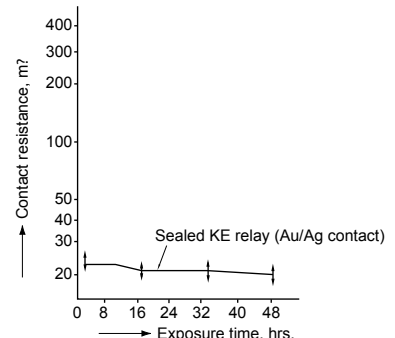

# DIMENSIONS

## 2 Form C

Plug-in terminal  
(K2EB)

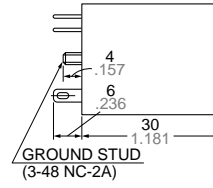
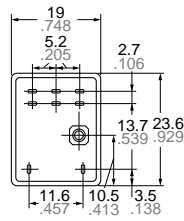
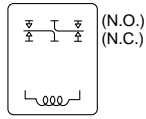

## 4 Form C

Plug-in terminal  
(K4EB)

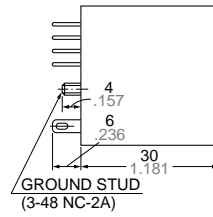
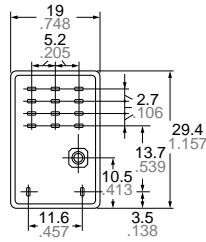
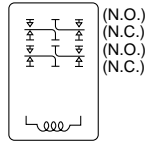

## 6 Form C

Plug-in terminal  
(K6EB)

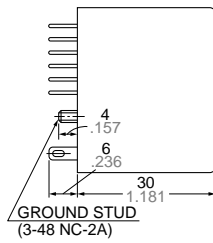
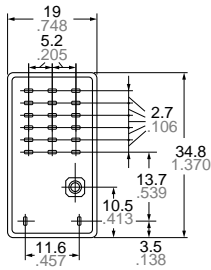
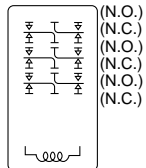





General tolerance:  $\pm 0.5 \pm .020$

**ACCESSORIES**

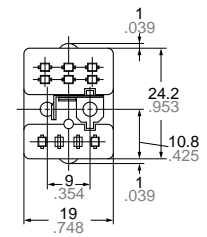
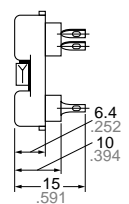
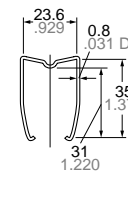
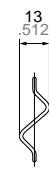

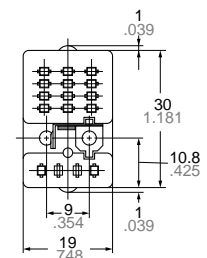
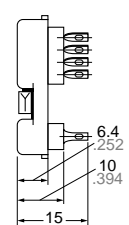
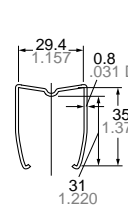

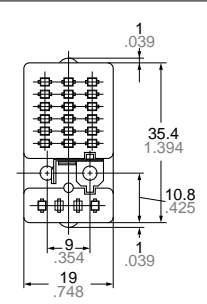
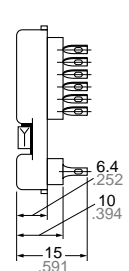
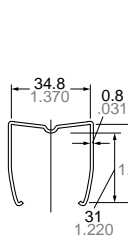
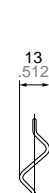
mm inch

**Solder terminal sockets (with hold-down clip)**

<p>K2-SS 2 Form C (for K2EB)</p>					
<p>K4-SS 4 Form C (for K4EB)</p>					
<p>K6-SS 6 Form C (for K6EB)</p>					

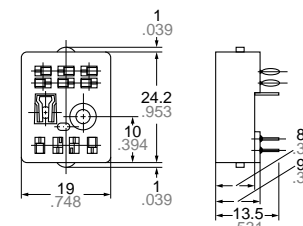
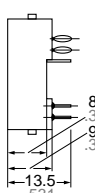
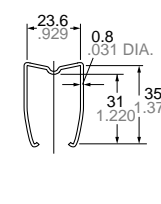
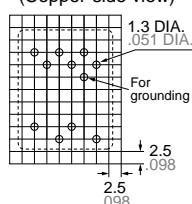
**PC board terminal sockets (with hold-down clip)**

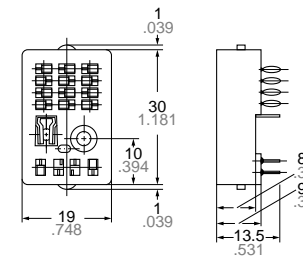
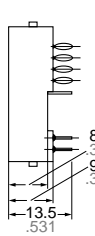
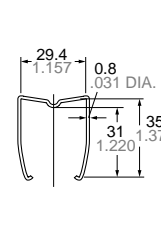
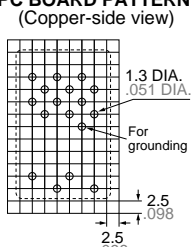
mm inch

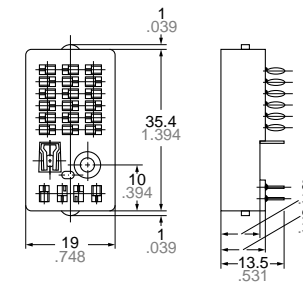
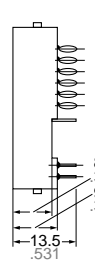
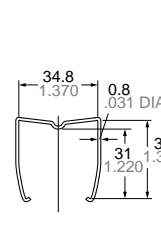
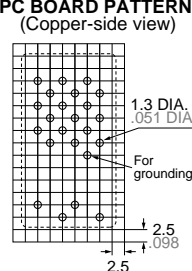
<p>K2-PS 2 Form C (for K2EB)</p>					<p><b>PC BOARD PATTERN (Copper-side view)</b></p> 
<p>K4-PS 4 Form C (for K4EB)</p>					<p><b>PC BOARD PATTERN (Copper-side view)</b></p> 
<p>K6-PS 6 Form C (for K6EB)</p>					<p><b>PC BOARD PATTERN (Copper-side view)</b></p> 

General tolerance:  $\pm 1 \pm .039$

# MOUNTING DIMENSIONS

## Plug-in socket mounting

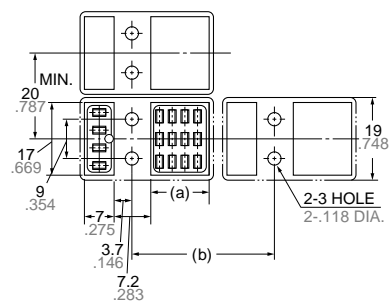
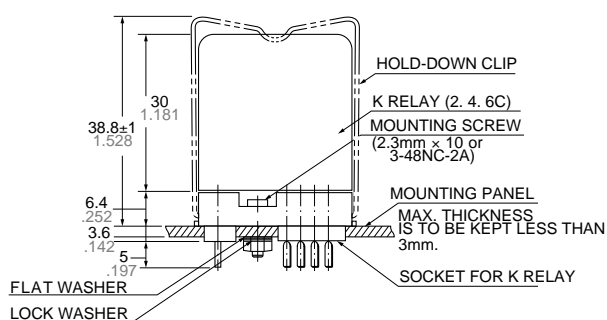

- (a)
- K2: 8.5 .335
- K4: 14 .551
- K6: 19.5 .768
- (b)
- K2: 26 1.024 MIN.
- K4: 31.8 1.252 MIN.
- K6: 37.2 1.465 MIN.

General tolerance:  $\pm 0.5 \pm .020$

Tolerance:  $\pm 0.1 \pm .004$

**For Cautions for Use, see Relay Technical Information in catalog.**